

**BID DOCUMENTS  
FOR**

**HIGHWAY 384  
HYDROLOGIC RESTORATION PROJECT  
MAINTENANCE EVENT**

**PROJECT NUMBER CS-21**

**CAMERON PARISH, LOUISIANA**



**STATE OF LOUISIANA  
COASTAL PROTECTION AND RESTORATION  
AUTHORITY**

**NOVEMBER 2014**

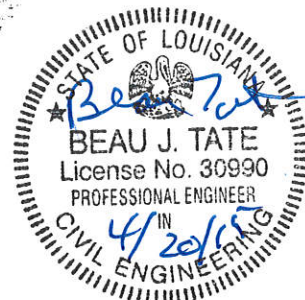

## TABLE OF CONTENTS

| <u>GENERAL REQUIREMENTS</u>   | <b>Pages Included</b> |
|---|-----------------------|
| Project Title Page  | 1                     |
| Table of Contents   | 3                     |
| List of Drawings  | 1                     |
| <b>Procurement Requirements</b>   |                       |
| Advertisement for Bids  | 1                     |
| <b>Instruction for Procurement</b>  |                       |
| Instructions to Bidders   | 7                     |
| <b>Procurement Forms and Supplements</b>  |                       |
| Louisiana Uniform Public Works Bid Form   | 2                     |
| Bid Security Form   | 1                     |
| Attestations  | 2                     |
| <b>Contracting Requirements</b>   |                       |
| Contract Between Owner & Contractor & Performance<br>& Payment Bond & Affidavit | 5                     |

| <u>Section</u> | <u>Title</u>  | <u>Page No.</u> |
|----------------|---|-----------------|
| <b>PART I</b>  | <b>GENERAL PROVISIONS .....</b>                               | <b>1</b>        |
| GP-1           | DEFINITION OF TERMS .....                                     | 1               |
| GP-2           | BID REQUIREMENTS.....   | 4               |
| GP-3           | AVAILABILITY OF PLANS AND SPECIFICATIONS.....                 | 5               |
| GP-4           | LAWS, REGULATIONS, STANDARDS, SPECIFICATIONS, AND CODES ..... | 5               |
| GP-5           | PRE-BID CONFERENCE AND SITE VISIT.....                        | 6               |
| GP-6           | NOTICE OF AWARD .....   | 6               |
| GP-7           | NOTICE TO PROCEED AND CONTRACT TIME.....                      | 7               |
| GP-8           | WORK PLAN .....   | 7               |
| GP-9           | PROGRESS SCHEDULE .....                                       | 8               |
| GP-10          | DAILY PROGRESS REPORTS.....                                   | 8               |
| GP-11          | HURRICANE AND SEVERE STORM PLAN .....                         | 9               |
| GP-12          | HEALTH AND SAFETY PLAN AND INSPECTIONS.....                   | 10              |
| GP-13          | PROGRESS MEETINGS AND REPORTS.....                            | 10              |
| GP-14          | PRE-CONSTRUCTION CONFERENCE .....                             | 11              |
| GP-15          | CONTRACT INTENT .....   | 11              |
| GP-16          | ENGINEER AND AUTHORITY OF ENGINEER .....                      | 11              |
| GP-17          | CONFORMITY WITH PLANS AND SPECIFICATIONS .....                | 11              |
| GP-18          | CLARIFICATIONS AND AMENDMENTS TO CONTRACT DOCUMENTS.....      | 12              |
| GP-19          | SUBCONTRACTS.....   | 12              |
| GP-20          | WORKERS, METHODS, AND EQUIPMENT.....                          | 12              |
| GP-21          | ACCIDENT PREVENTION, INVESTIGATIONS, AND REPORTING .....      | 13              |
| GP-22          | PRESERVATION AND RESTORATION OF PROPERTY, MONUMENTS, ETC..... | 14              |

|       |   |    |
|-------|---|----|
| GP-23 | PROTECTION OF THE WORK, MATERIALS, AND EQUIPMENT.....             | 14 |
| GP-24 | LAND RIGHTS.....  | 14 |
| GP-25 | UTILITIES.....  | 15 |
| GP-26 | PERMITS.....  | 15 |
| GP-27 | PROJECT SITE CLEAN-UP.....  | 15 |
| GP-28 | OWNER INSPECTION.....   | 16 |
| GP-29 | DUTIES OF RESIDENT PROJECT REPRESENTATIVE.....                    | 16 |
| GP-30 | CONSTRUCTION STAKES, LINES, AND GRADES.....                       | 16 |
| GP-31 | CONTRACTOR'S RESPONSIBILITY FOR WORK.....                         | 17 |
| GP-32 | ENVIRONMENTAL PROTECTION.....                                     | 17 |
| GP-33 | SANITARY PROVISION.....   | 17 |
| GP-34 | PAYMENT OF TAXES.....   | 18 |
| GP-35 | RADIO AND TELEPHONES.....   | 18 |
| GP-36 | NAVIGATION.....   | 18 |
| GP-37 | OBSTRUCTION TO NAVIGATION.....                                    | 18 |
| GP-38 | MARINE VESSELS AND MARINE ACTIVITIES.....                         | 18 |
| GP-39 | RECORD KEEPING.....   | 19 |
| GP-40 | CERTIFICATES OF COMPLIANCE.....                                   | 19 |
| GP-41 | SUBMITTALS.....   | 19 |
| GP-42 | CLAIMS FOR EXTRA COST.....  | 20 |
| GP-43 | ALTERATION OF THE CONTRACT AND COMPENSATION.....                  | 20 |
| GP-44 | EXTENSION OF CONTRACT TIME.....                                   | 21 |
| GP-45 | OWNER'S RIGHT TO TERMINATE CONTRACT FOR CAUSE OR CONVENIENCE..... | 21 |
| GP-46 | TEMPORARY SUSPENSION OF WORK.....                                 | 22 |
| GP-47 | NON-CONFORMING AND UNAUTHORIZED WORK.....                         | 22 |
| GP-48 | CONTRACTOR'S RIGHT TO TERMINATE CONTRACT.....                     | 23 |
| GP-49 | BREACH OF CONTRACT.....   | 23 |
| GP-50 | NO WAIVER OF LEGAL RIGHTS.....                                    | 23 |
| GP-51 | LIABILITY FOR DAMAGES AND INJURIES.....                           | 23 |
| GP-52 | LIABILITY FOR LOSSES BY ACTS OF THE GOVERNMENT.....               | 24 |
| GP-53 | SUBSTANTIAL COMPLETION.....                                       | 24 |
| GP-54 | FINAL INSPECTION AND ACCEPTANCE.....                              | 25 |
| GP-55 | AS-BUILT DRAWINGS.....  | 25 |
| GP-56 | COMPLETION OF CONTRACT.....                                       | 26 |
| GP-57 | CONTRACTOR'S GUARANTEE.....                                       | 26 |
| GP-58 | DISPUTE RESOLUTION.....   | 27 |
| GP-59 | PAYMENT.....  | 27 |
| GP-60 | PAYMENTS WITHHELD.....  | 28 |
| GP-61 | LIENS.....  | 29 |
| GP-62 | EQUAL EMPLOYMENT OPPORTUNITY.....                                 | 29 |
| GP-63 | ANTI-KICKBACK CLAUSE.....   | 29 |
| GP-64 | SUSPENSION/DEBARMENT.....   | 29 |
| GP-65 | LOUISIANA FIRST HIRING ACT.....                                   | 30 |

**PART II: SPECIAL PROVISIONS..... 32**

|      |  |    |
|------|--|----|
| SP-1 | LOCATION OF WORK.....                            | 32 |
| SP-2 | WORK TO BE DONE.....                             | 32 |
| SP-3 | BID ITEMS, CONTRACT DATES, AND DELIVERABLES..... | 33 |
| SP-4 | DELIVERABLES.....                                | 33 |
| SP-5 | CONTACT INFORMATION.....                         | 36 |

|  |  |           |
|--|--|-----------|
| SP-6   | WORK PLAN SUPPLEMENTAL .....             | 37        |
| SP-7   | FAILURE TO COMPLETE ON TIME .....        | 37        |
| SP-8   | TRANSPORTATION .....                     | 37        |
| SP-9   | RESERVED .....                           | 38        |
| SP-10  | OFFICE FOR OWNER.....                    | 38        |
| SP-11  | LANDOWNER AND PIPELINE REQUIREMENTS..... | 38        |
| SP-12  | OYSTER LEASE RESTRICTIONS .....          | 38        |
| SP-13  | INSURANCE AND BONDS.....                 | 39        |
| <b>PART III TECHNICAL SPECIFICATIONS .....</b>                       |  | <b>45</b> |
| TS-1   | SCOPE OF WORK .....                      | 45        |
| TS-2   | MOBILIZATION/DEMobilIZATION .....        | 46        |
| TS-3   | STRUCTURE MAINTENANCE .....              | 47        |
| TS-4   | LEVEE REPAIR.....                        | 48        |
| TS-5   | DREDGING OF INLET CHANNEL .....          | 52        |
| TS-6   | CONSTRUCTION SURVEY .....                | 53        |
| APPENDIX A: CLARIFICATION, CHANGE ORDERS, AND ACCEPTANCE FORMS ..... |  | 56        |
| APPENDIX B: LANDRIGHTS MEMORANDUM .....                              |  | 61        |
| APPENDIX C: GOVERNMENT PERMITS .....                                 |  | 65        |
| APPENDIX D: SURVEY CONTROL.....                                      |  | 76        |
| APPENDIX E: PREVAILING WAGE DETERMINATION SCHEDULE.....              |  | 80        |

## LIST OF DRAWING SHEETS

| SHEET NUMBER | DESCRIPTION                                    |
|--------------|--|
| 1            | Title Sheet                                    |
| 2            | General Notes                                  |
| 3            | Overall Site Map                               |
| 4            | Site Plan- Levee Repair                        |
| 5            | Profile and Typical Cross-Section-Levee Repair |
| 6            | Cross-Sections- Levee Repair                   |
| 7            | Cross-Sections- Levee Repair                   |
| 8            | Cross-Sections- Levee Repair                   |
| 9            | Cross-Sections- Levee Repair                   |
| 10           | Cross-Sections- Levee Repair                   |
| 11           | Cross-Sections- Levee Repair                   |
| 12           | Cross-Sections- Levee Repair                   |
| 13           | Cross-Sections- Levee Repair                   |
| 14           | Cross-Sections- Levee Repair                   |
| 15           | Site Plan- Channel Cleanout                    |
| 16           | Profile and Typical Cross-Section- Channel     |
| 17           | Cross-Sections- Channel Cleanout               |
| 18           | Cross-Sections- Channel Cleanout               |
| 19           | Cross-Sections- Channel Cleanout               |
| 20           | Cross-Sections- Channel Cleanout               |
| 21           | Cross-Sections- Channel Cleanout               |
| 22           | Cross-Sections- Channel Cleanout               |
| 23           | Cross-Sections- Channel Cleanout               |
| 24           | Cross-Sections- Channel Cleanout               |
| 25           | Site Plan- Structure Maintenance               |

**This Page Intentionally Left Blank**

ADVERTISEMENT FOR BIDS

Sealed bids will be received for the State of Louisiana by the Division of Administration, Office of Facility Planning and Control, Claiborne Office Building, 1201 North Third Street, Conference Room 1-145, Post Office Box 94095, Baton Rouge, Louisiana 70804-9095 until 2:00 P.M., **Thursday, May 28, 2015.**

ANY PERSON REQUIRING SPECIAL ACCOMMODATIONS SHALL NOTIFY FACILITY PLANNING AND CONTROL OF THE TYPE(S) OF ACCOMMODATION REQUIRED NOT LESS THAN SEVEN (7) DAYS BEFORE THE BID OPENING.

FOR: **Highway 384 Hydrologic Restoration Project  
Maintenance Event  
Cameron Parish, Louisiana**

PROJECT NUMBER: **CS-21**

Complete Bid Documents for this project are available in electronic form. They may be obtained without charge and without deposit from <http://dnr.louisiana.gov/index.cfm?md=pagebuilder&tmp=home&pid=432>. Printed copies can also be obtained from CPRA.

Questions about this procedure shall be directed to Renee McKee:

Coastal Protection and Restoration Authority (CPRA)

450 Laurel Street

Suite 1501

Baton Rouge, LA 70801

Telephone: 225-342-0811

Fax: 225-342-4674

E-mail: [cpra.bidding@la.gov](mailto:cpra.bidding@la.gov)

All bids shall be accompanied by bid security in an amount of five percent (5.0%) of the sum of the base bid and all alternates. The form of this security shall be as stated in the Instructions to Bidders included in the Bid Documents for this project.

The successful Bidder shall be required to furnish a Performance and Payment Bond written as described in the Instructions to Bidders included in the Bid Documents for this project.

**A MANDATORY PRE-BID CONFERENCE WILL BE HELD  
at 10:00 AM on Monday, May 11, 2015 at USDA-Natural Resource Conservation Services Field Office,  
5417 Gerstner Memorial Drive, Lake Charles.**

**BIDS SHALL BE ACCEPTED ONLY FROM CONTRACTORS THAT ATTEND THE ENTIRE PRE-BID CONFERENCE.**

A HIGHLY ENCOURAGE JOBSITE VISIT will be held immediately following the pre-bid conference.

The jobsite visit is not mandatory, but it is highly encouraged for those submitting a bid. The jobsite visit being conducted by CPRA will facilitate access to project features that are located on private property. Outside of the recommended site visit, the Contractor may not have access to the features located on private property. The jobsite visit will begin with the portion of the project area accessible only by airboat. Contractors shall be responsible for providing their own airboat and any rental and boat launching fees.

Contact Jody White with CPRA at (337) 482-0664 if directions are needed to the Mandatory Pre-Bid Conference or the highly encouraged Jobsite Visit.

Bids shall be accepted from Contractors who are licensed under LA. R.S. 37:2150-2192 for the classification of **Heavy Construction**. In accordance with LA. R.S. 37:2163(D), anyone objecting to the classification must send a certified letter to both the Louisiana State Licensing Board for Contractors and the CPRA at the address listed above. The letter must be received no later than ten (10) working days prior to the day on which bids are to be opened.

Bidder is required to comply with provisions and requirements of LA R.S. 38:2212(B)(5). No bid may be withdrawn for a period of forty-five (45) days after receipt of bids, except under the provisions of LA. R.S. 38:2214.

The Owner reserves the right to reject any and all bids for just cause. In accordance with La. R.S. 38:2212(B)(1), the provisions and requirements of this Section; and those stated in the bidding documents shall not be waived by any entity.

When this project is financed either partially or entirely with State Bonds or financed in whole or in part by federal or other funds which are not readily available at the time bids are received, the award of this Contract is contingent upon the granting of lines of credit, or the sale of bonds by the Bond Commission or the availability of federal or other funds. The State shall incur no obligation to the Contractor until the Contract Between Owner and Contractor is fully executed.

Coastal Protection and Restoration Authority is a participant in the Small Entrepreneurship (SE) Program (the Hudson Initiative) and the Veteran-Owned and Service-Connected Disabled Veteran-Owned (LaVet) Small Entrepreneurship Program. Bidders are encouraged to consider participation. Information is available from Coastal Protection and Restoration Authority or on its website at <http://coastal.la.gov/>.

STATE OF LOUISIANA  
DIVISION OF ADMINISTRATION  
FACILITY PLANNING AND CONTROL  
MARK A. MOSES, DIRECTOR

**This Page Intentionally Left Blank**



# INSTRUCTIONS TO BIDDERS

## COMPLETION TIME:

The Bidder shall agree to fully complete the contract within **Thirty (30)** consecutive calendar days, subject to such extensions as may be granted under Section GP-44 of the General Provisions and acknowledges that this construction time will start on or before the date specified in the written "Notice to Proceed" from the Owner.

## LIQUIDATED DAMAGES:

The Bidder shall agree to pay as Liquidated Damages the amount of **Five Hundred Dollars (\$500.00)** for each consecutive calendar day for which the work is not complete, beginning with the first day beyond the contract completion date stated on the "Notice to Proceed" or as amended by change order.

## ARTICLE 1

### DEFINITIONS

1.1 The Bid Documents include the following:

- Advertisement for Bids
- Instructions to Bidders
- Bid Form
- Bid Bond
- General Provisions
- Special Provisions
- Technical Specifications
- Construction Drawings
- Contract Between Owner and Contractor and Performance and Payment Bond
- Affidavit
- User Agency Documents (if applicable)
- Change Order Form
- Recommendation of Acceptance
- Other Documents (if applicable)
- Addenda issued during the bid period and acknowledged in the Bid Form

1.2 All definitions set forth in the General Provisions and the Special Provisions are applicable to the Bid Documents, unless otherwise specifically stated or written.

1.3 Addenda are written and/or graphic instruments issued by the Engineer prior to the opening of bids which modify or interpret the Bid Documents by additions, deletions, clarifications, corrections and

prior approvals.

1.4 A bid is a complete and properly signed proposal to do the work or designated portion thereof for the sums stipulated therein supported by data called for by the Bid Documents.

1.5 Base bid is the sum stated in the bid for which the Bidder offers to perform the work described as the base, to which work may be added, or deleted for sums stated in alternate bids.

1.6 An alternate bid (or alternate) is an amount stated in the bid to be added to the amount of the base bid if the corresponding change in project scope or materials or methods of construction described in the Bid Documents is accepted.

1.7 A Bidder is one who submits a bid for a prime Contract with the Owner for the work described in the Bid Documents.

1.8 A Sub-bidder is one who submits a bid to a Bidder for materials and/or labor for a portion of the work.

1.9 Where the word "Engineer" is used in any of the documents, it shall refer to the Prime Designer of the project, regardless of discipline.

## ARTICLE 2

### PRE-BID CONFERENCE

2.1 A Pre-Bid Conference may be held at the time and location described in the Advertisement for Bids. The purpose of the Pre-Bid Conference is to familiarize Bidders with the requirements of the Project and the intent of the Bid Documents, and to receive comments and information from interested Bidders. If the Pre-Bid Conference and/or Job Site Visit is stated in the Advertisement for Bids to be a Mandatory Pre-Bid Conference and/or Mandatory Job Site Visit, bids shall be accepted only from those bidders who attend the Pre-Bid Conference and/or Job Site Visit. Contractors who are not in attendance for the entire Pre-Bid Conference and/or Job Site Visit will be considered to have not attended.

2.2 Any revision of the Bid Documents made as a result of the Pre-Bid Conference shall not be valid unless included in an addendum.

### **ARTICLE 3**

#### **BIDDER'S REPRESENTATION**

3.1 Each Bidder by making his bid represents that:

3.1.1 He has read and understands the Bid Documents and his bid is made in accordance therewith.

3.1.2 He has visited the site and has familiarized himself with the local conditions under which the work is to be performed.

3.1.3 His bid is based solely upon the materials, systems and equipment described in the Bid Documents as advertised and as modified by addenda.

3.1.4 His bid is not based on any verbal instructions contrary to the Bid Documents and addenda.

3.1.5 He is familiar with the Code of Governmental Ethics requirement that prohibits public servants and/or their immediate family members from bidding on or entering into contracts; he is aware that the Designer and its principal owners are considered Public Servants under the Code of Governmental Ethics for the limited purposes and scope of the Design Contract with the State on this Project (see Ethics Board

Advisory Opinion, No. 2009-378 and 2010-128); and neither he nor any principal of the Bidder with a controlling interest therein has an immediate family relationship with the Designer or any principal within the Designer's firm. (see La. R.S. 42:1113). Any Bidder submitting a bid in violation of this clause shall be disqualified and any contract entered into in violation of this clause shall be null and void.

3.2 The Bidder must be fully qualified under any State or local licensing law for Contractors in effect at the time and at the location of the work before submitting his bid. In the State of Louisiana, Revised Statutes 37:2150, et seq. will be considered, if applicable.

The Contractor shall be responsible for determining that all of his Sub-bidders or prospective Subcontractors are duly licensed in accordance with law.

### **ARTICLE 4**

#### **BID DOCUMENTS**

4.1 Copies

4.1.1 Bid Documents may be obtained from the Coastal Protection and Restoration Authority as stated in the Advertisement for Bids.

4.1.1.2 In addition to the availability of printed Bid Documents, the Coastal Protection and Restoration Authority will provide the Bid Documents in electronic format. They may be obtained without charge and without deposit as stated in the Advertisement for Bids.

4.1.1.2.2 Where electronic distribution is provided, all other plan holders are responsible for their own reproduction costs.

4.1.2 Complete sets of Bid Documents shall be used in preparing bids; neither the Owner nor the Engineer assume any responsibility for errors or misinterpretations resulting from the use of incomplete sets of Bid Documents.

4.1.3 The Owner or Engineer in making copies of the Bid Documents available on the above

terms, do so only for the purpose of obtaining bids on the work and do not confer a license or grant for any other use.

#### 4.2 Interpretation or Correction of Bid Documents

4.2.1 Bidders shall promptly notify the Coastal Protection and Restoration Authority contact person listed in the Advertisement for Bids of any ambiguity, inconsistency or error which they may discover upon examination of the Bid Documents or of the site and local conditions.

4.2.2 Bidders requiring clarification or interpretation of the Bid Documents shall make a written request to the Coastal Protection and Restoration Authority contact person listed in the Advertisement for Bids, to reach him at least seven days prior to the date for receipt of bids.

4.2.3 Any interpretation, correction or change of the Bid Documents will be made by addendum. Interpretations, corrections or changes of the Bid Documents made in any other manner will not be binding and Bidders shall not rely upon such interpretations, corrections and changes.

#### 4.3 Substitutions

4.3.1 The materials, products and equipment described in the Bid Documents establish a standard of required function, dimension, appearance and quality to be met by any proposed substitution. No substitutions shall be allowed after bids are received.

4.3.2 No substitution will be considered unless written request for approval has been submitted by the Proposer and has been received by the Engineer at least seven (7) working days prior to the opening of bids. (RS38:2295C) Each such request shall include the name of the material or equipment for which it is to be substituted and a complete description of the proposed substitute including model numbers, drawings, cuts, performance and test data and any other information necessary for an evaluation. A statement setting forth any changes in other materials, equipment or work that incorporation of the substitute would require shall be included. It shall be the responsibility of the proposer to include in his proposal all changes required of the

Bid Documents if the proposed product is used. Prior approval is given contingent upon supplier being responsible for any costs which may be necessary to modify the space or facilities needed to accommodate the materials and equipment approved.

4.3.3 If the Engineer approves any proposed substitution, such approval will be set forth in an addendum. Bidders shall not rely upon approvals made in any other manner.

#### 4.4 Addenda

4.4.1 Addenda will be mailed or delivered to all who are known by the Coastal Protection and Restoration Authority to have received a complete set of Bid Documents.

4.4.2 Copies of addenda will be made available for inspection wherever Bid Documents are on file for that purpose.

4.4.3 Except as described herein, addenda shall not be issued within a period of seventy-two (72) hours prior to the advertised time for the opening of bids, excluding Saturdays, Sundays, and any other legal holidays. If the necessity arises of issuing an addendum modifying the Bid Documents within the seventy-two (72) hour period prior to the advertised time for the opening of bids, then the opening of bids shall be extended at least seven but no more than twenty-one (21) working days, without the requirement of re-advertising. The revised time and date for the opening of bids shall be stated in the addendum.

4.4.4 Each Bidder shall ascertain from the Coastal Protection and Restoration Authority prior to submitting his bid that he has received all addenda issued, and he shall acknowledge their receipt on the Bid Form.

4.4.5 The Owner shall have the right to extend the bid date by up to (30) thirty days without the requirement of re-advertising. Any such extension shall be made by addendum issued by the Coastal Protection and Restoration Authority.

### ARTICLE 5

#### BID PROCEDURE

## 5.1 Form and Style of Bids

5.1.1 Bids shall be submitted on the Louisiana Uniform Public Work Bid Form provided by the Engineer.

5.1.2 All blanks on the Bid Form shall be filled in manually in ink or typewritten.

5.1.3 Bid sums shall be expressed in both words and figures, and in case of discrepancy between the two, the written words shall govern.

5.1.4 Any interlineation, alteration or erasure must be initialed by the signer of the bid or his authorized representative.

5.1.5 Bidders are cautioned to complete all alternates should such be required in the Bid Form. Failure to submit alternate prices will render the bid non responsive and shall cause its rejection.

5.1.6 Bidders are cautioned to complete all unit prices should such be required in the Bid Form. Unit prices represent a price proposal to do a specified quantity and quality of work.

5.1.7 Bidders are strongly cautioned to ensure that all blanks on the bid form are completely and accurately filled in.

5.1.8 Bidder shall make no additional stipulations on the Bid Form nor qualify his bid in any other manner.

5.1.9 The bid shall include the legal name of Bidder. Written evidence of the authority of the person signing the bid shall be submitted at the time of bidding.

The authority of the signature of the person submitting the bid shall be deemed sufficient and acceptable under any of the following conditions:

(a) Signature on bid is that of any corporate officer listed on the most current annual report on file with the Secretary of State, or the signature on the bid is that of any member of a partnership, limited liability company, limited liability partnership, or other legal entity listed in the most current business records on file with the Secretary of State.

(b) Signature on bid is that of authorized representative as documented by the legal entity certifying the authority of the person.

(c) Legal entity has filed in the appropriate records of the Secretary of State, an affidavit, resolution or other acknowledged or authentic document indicating the names of all parties authorized to submit bids for public contracts. Such document on file with the Secretary of State shall remain in effect and shall be binding upon the principal until specifically rescinded and canceled from the records of the office. A bid submitted by an agency shall have a current Power of Attorney attached certifying agent's authority to bind Bidder. The name and license number on the envelope shall be the same as the entity identified on the Bid Form.

5.1.10 On any bid in excess of fifty thousand dollars (\$50,000.00), the Contractor shall certify that he is licensed under R.S. 37: 2150-2173 and show his license number on the bid above his signature or his duly authorized representative.

## 5.2 Bid Security

5.2.1 No bid shall be considered or accepted unless the bid is accompanied by bid security in an amount of five percent (5.0%) of the base bid and all alternates.

The bid security shall be in the form of a certified check or cashier's check drawn on a bank insured by the Federal Deposit Insurance Corporation, or a Bid Bond written by a surety company licensed to do business in Louisiana and signed by the surety's agent or attorney-in-fact. The Bid Bond shall be written on the Coastal Protection and Restoration Authority Bid Bond Form, and the surety for the bond must meet the qualifications stated thereon. The Bid Bond shall include the legal name of the bidder be in favor of the State of Louisiana, Coastal Protection and Restoration Authority, and shall be accompanied by appropriate power of attorney. The Bid Bond must be signed by both the bidder/principal and the surety in the space provided on the Coastal Protection and Restoration Authority Bid Bond Form. Failure by the bidder/principal or the surety to sign the bid bond shall result in the rejection of the bid.

Bid security furnished by the Contractor shall guarantee that the Contractor will, if awarded the

work according to the terms of his proposal, enter into the Contract and furnish Performance and Payment Bonds as required by these Bid Documents, within ten (10) days after written notice that the instrument is ready for his signature.

Should the Bidder refuse to enter into such Contract or fail to furnish such bonds, the amount of the bid security shall be forfeited to the Owner as liquidated damages, not as penalty.

5.2.2 The Owner will have the right to retain the bid security of Bidders until either (a) the Contract has been executed and bonds have been furnished, or (b) the specified time has elapsed so that bids may be withdrawn, or (c) all bids have been rejected.

### 5.3 Submission of Bids

5.3.1 The Bid shall be sealed in an opaque envelope. The bid envelope shall be identified on the outside with the name of the project, and the name, address, and license number of the Bidder. The envelope shall contain **only one bid form** and will be received until the time specified and at the place specified in the Advertisement for Bids. It shall be the specific responsibility of the Bidder to deliver his sealed bid to Facility Planning and Control Department at the appointed place and prior to the announced time for the opening of bids. Late delivery of a bid for any reason, including late delivery by United States Mail, or express delivery, shall disqualify the bid.

If the bid is sent by mail, the sealed envelope shall be enclosed in a separate mailing envelope with the notation "Bid Enclosed" on the face thereof. Such bids shall be sent by Registered or Certified Mail, Return Receipt Requested, addressed to:

Facility Planning and Control,  
P. O. Box 94095  
Baton Rouge, Louisiana, 70804-9095.

Bids sent by express delivery shall be delivered to:  
Facility Planning and Control  
Suite 7-160  
Claiborne Office Building  
1201 North Third Street  
Baton Rouge, Louisiana 70802

5.3.2 Bids shall be deposited at the designated location prior to the time on the date for receipt of bids indicated in the Advertisement for Bids, or any extension thereof made by addendum. Bids received after the time and date for receipt of bids will be returned unopened.

5.3.3 Bidder shall assume full responsibility for timely delivery at location designated for receipt of bids.

5.3.4 Oral, telephonic or telegraphic bids are invalid and shall not receive consideration. Owner shall not consider notations written on outside of bid envelope which have the effect of amending the bid. Written modifications enclosed in the bid envelope, and signed or initialed by the Contractor or his representative, shall be accepted.

### 5.4 Modification or Withdrawal of Bid

5.4.1 A bid may not be modified, withdrawn or canceled by the Bidder during the time stipulated in the Advertisement for Bids, for the period following the time and bid date designated for the receipt of bids, and Bidder so agrees in submitting his bid, except in accordance with R.S. 38:2214 which states, in part, "Bids containing patently obvious mechanical, clerical or mathematical errors may be withdrawn by the Contractor if clear and convincing sworn, written evidence of such errors is furnished to the public entity within forty eight hours of the Bid Opening excluding Saturdays, Sundays and legal holidays".

5.4.2 Prior to the time and date designated for receipt of bids, bids submitted early may be modified or withdrawn only by notice to the party receiving bids at the place and prior to the time designated for receipt of bids.

5.4.3 Withdrawn bids may be resubmitted up to the time designated for the receipt of bids provided that they are then fully in conformance with these Instructions to Bidders.

5.4.4 Bid Security shall be in an amount sufficient for the bid as modified or resubmitted.

## ARTICLE 6

### CONSIDERATION OF BIDS

## 6.1 Opening of Bids

6.1.1 The properly identified Bids received on time will be opened publicly and will be read aloud, and a tabulation abstract of the amounts of the base bids and alternates, if any, will be made available to Bidders.

## 6.2 Rejection of Bids

6.2.1 The Owner shall have the right to reject any or all bids and in particular to reject a bid not accompanied by any required bid security or data required by the Bid Documents or a bid in any way incomplete or irregular.

## 6.3 Acceptance of Bid

6.3.2 It is the intent of the Owner, if he accepts any alternates, to accept them in the order in which they are listed in the Bid Form. Determination of the Low Bidder shall be on the basis of the sum of the base bid and the alternates accepted. However, the Owner shall reserve the right to accept alternates in any order which does not affect determination of the Low Bidder.

## ARTICLE 7

### POST-BID INFORMATION

#### 7.1 Submissions

7.1.1 The Contractor shall submit all required deliverables in conformance with Section SP-4 of the Special Provisions.

It is the preference of the Owner that, to the greatest extent possible or practical, the Contractor utilize Louisiana Subcontractors, manufacturers, suppliers and labor.

7.1.2 The Contractor will be required to establish to the satisfaction of the Engineer the reliability and responsibility of the proposed Subcontractors to furnish and perform the work described in the sections of the Specifications pertaining to such proposed Subcontractor's respective trades. The General Contractor shall be responsible for actions or inactions of Subcontractors and/or material suppliers.

The General Contractor is totally responsible

for any lost time or extra expense incurred due to a Subcontractor's/or Material Supplier's failure to perform. Failure to perform includes, but is not limited to, a Subcontractor's financial failure, abandonment of the project, failure to make prompt delivery, or failure to do work up to standard. Under no circumstances shall the Owner mitigate the General Contractor's losses or reimburse the General Contractor for losses caused by these events.

7.1.3 Subcontractors and other persons and organizations selected by the Bidder must be used on the work for which they were proposed and shall not be changed except with the written approval of the Owner and the Engineer.

In accordance with La. R.S. 38:2227, LA. R.S. 38:2212.10 and LA. R.S. 23:1726(B) the low bidder on this project must submit the completed Attestations Affidavit (Past Criminal Convictions of Bidders, Verification of Employees and Certification Regarding Unpaid Workers Compensation Insurance) form found within this bid package. The Attestations Affidavit form shall be submitted to Facility Planning and Control within 10 days after the opening of bids.

## ARTICLE 8

### PERFORMANCE AND PAYMENT BOND

#### 8.1 Bond Required

8.1.1 The Contractor shall furnish and pay for a Performance and Payment Bond written by a company licensed to do business in Louisiana, which shall be signed by the surety's agent or attorney-in-fact, in an amount equal to 100% of the Contract amount. Surety must be listed currently on the U. S. Department of Treasury Financial Management Service List (Treasury List) as approved for an amount equal to or greater than the contract amount, or must be an insurance company domiciled in Louisiana or owned by Louisiana residents. If surety is qualified other than by listing on the Treasury list, the contract amount may not exceed fifteen percent of policyholders' surplus as shown by surety's most recent financial statements filed with the Louisiana Department of Insurance and may not exceed the amount of \$500,000. However, a Louisiana

domiciled insurance company with at least an A-rating in the latest printing of the A. M. Best's Key Rating Guide shall not be subject to the \$500,000 limitation, provided that the contract amount does not exceed ten percent of policyholders' surplus as shown in the latest A. M. Best's Key Rating Guide nor fifteen percent of policyholders' surplus as shown by surety's most recent financial statements filed with the Louisiana Department of Insurance. The Bond shall be signed by the surety's agent or attorney-in-fact. The Bond shall be in favor of the Coastal Protection and Restoration Authority.

## 8.2 Time of Delivery and Form of Bond

8.2.1 The Bidder shall deliver the required bond to the Owner simultaneous with the execution of the Contract.

8.2.2 Bond shall be in the form furnished by the Coastal Protection and Restoration Authority, entitled CONTRACT BETWEEN OWNER AND CONTRACTOR AND PERFORMANCE AND PAYMENT BOND, a copy of which is included in the Bid Documents.

8.2.3 The Bidder shall require the Attorney-in-Fact who executes the required bond on behalf of the surety to affix thereto a certified and current copy of his power of Attorney.

bid to sign on behalf of the Contractor.

9.2.2 In accordance with Louisiana Law, when the Contract is awarded, the successful Bidder shall, at the time of the signing of the Contract, execute the Non-Collusion Affidavit included in the Contract Documents

9.2.3 When this project is financed either partially or entirely with State Bonds, the award of this Contract is contingent upon the sale of bonds by the State Bond Commission. The State shall incur no obligation to the Contractor until the Contract between Owner and Contractor is duly executed.

## **ARTICLE 9**

### **FORM OF AGREEMENT BETWEEN OWNER AND CONTRACTOR**

#### 9.1 Form to be Used

9.1.1 Form of the Contract to be used shall be furnished by the Coastal Protection and Restoration Authority, an example of which is bound in the Bid Documents.

#### 9.2 Award

9.2.1 Before award of the Contract, the successful Bidder shall furnish to the Owner a copy of a Disclosure of Ownership Affidavit stamped by the Secretary of State, a certified copy of the minutes of the corporation or partnership meeting which authorized the party executing the

**This Page Intentionally Left Blank**



# LOUISIANA UNIFORM PUBLIC WORK BID FORM

**TO:** FACILITY PLANNING AND CONTROL  
CLAIBORNE BUILDING  
P.O. BOX 94095  
BATON ROUGE, LA 70804

*(Owner to provide name and address of owner)*

**BID FOR:** HIGHWAY 384  
HYDROLOGIC RESTORATION PROJECT  
MAINTENANCE EVENT  
CS-21

*(Owner to provide name of project and other identifying information)*

The undersigned bidder hereby declares and represents that she/he; a) has carefully examined and understands the Bidding Documents, b) has not received, relied on, or based his bid on any verbal instructions contrary to the Bidding Documents or any addenda, c) has personally inspected and is familiar with the project site, and hereby proposes to provide all labor, materials, tools, appliances and facilities as required to perform, in a workmanlike manner, all work and services for the construction and completion of the referenced project, all in strict accordance with the Bidding Documents prepared by: Royal Engineers & Consultants, LLC. and dated: November 2014.

*(Owner to provide name of entity preparing bidding documents.)*

Bidders must acknowledge all addenda. The Bidder acknowledges receipt of the following **ADDENDA:** (Enter the number the Designer has assigned to each of the addenda that the Bidder is acknowledging) \_\_\_\_\_ .

**TOTAL BASE BID:** For all work required by the Bidding Documents (including any and all unit prices designated "Base Bid" \* but not alternates) the sum of:

\_\_\_\_\_ Dollars (\$ \_\_\_\_\_)

**ALTERNATES:** For any and all work required by the Bidding Documents for Alternates including any and all unit prices designated as alternates in the unit price description.

**Alternate No. 1** *(Owner to provide description of alternate and state whether add or deduct)* for the lump sum of:

\_\_\_\_\_ Not Applicable \_\_\_\_\_ Dollars (\$ \_\_\_\_\_ N/A \_\_\_\_\_)

**Alternate No. 2** *(Owner to provide description of alternate and state whether add or deduct)* for the lump sum of:

\_\_\_\_\_ Not Applicable \_\_\_\_\_ Dollars (\$ \_\_\_\_\_ N/A \_\_\_\_\_)

**Alternate No. 3** *(Owner to provide description of alternate and state whether add or deduct)* for the lump sum of:

\_\_\_\_\_ Not Applicable \_\_\_\_\_ Dollars (\$ \_\_\_\_\_ N/A \_\_\_\_\_)

**NAME OF BIDDER:** \_\_\_\_\_

**ADDRESS OF BIDDER:** \_\_\_\_\_

**LOUISIANA CONTRACTOR'S LICENSE NUMBER:** \_\_\_\_\_

**NAME OF AUTHORIZED SIGNATORY OF BIDDER:** \_\_\_\_\_

**TITLE OF AUTHORIZED SIGNATORY OF BIDDER:** \_\_\_\_\_

**SIGNATURE OF AUTHORIZED SIGNATORY OF BIDDER \*\*:** \_\_\_\_\_

**DATE:** \_\_\_\_\_

\* The Unit Price Form shall be used if the contract includes unit prices. Otherwise it is not required and need not be included with the form. The number of unit prices that may be included is not limited and additional sheets may be included if needed.

\*\* If someone other than a corporate officer signs for the Bidder/Contractor, a copy of a corporate resolution or other signature authorization shall be required for submission of bid. Failure to include a copy of the appropriate signature authorization, if required, may result in the rejection of the bid unless bidder has complied with La. R.S. 38:2212(B)(5).

**BID SECURITY** in the form of a bid bond, certified check or cashier's check as prescribed by LA RS 38:2218.A is attached to and made a part of this bid.

# LOUISIANA UNIFORM PUBLIC WORK BID FORM

## UNIT PRICE FORM

**TO:** FACILITY PLANNING AND CONTROL  
 CLAIBORNE BUILDING  
 P.O. BOX 94095  
 BATON ROUGE, LA 70804  
*(Owner to provide name and address of owner)*

**BID FOR:** HIGHWAY 384  
 HYDROLOGIC RESTORATION PROJECT  
 MAINTENANCE EVENT  
 CS-21  
*(Owner to provide name of project and other identifying information)*

**UNIT PRICES:** This form shall be used for any and all work required by the Bidding Documents and described as unit prices. Amounts shall be stated in figures and only in figures.

|              |  |  |
|--------------|--|--|
| DESCRIPTION: | <input checked="" type="checkbox"/> Base Bid or <input type="checkbox"/> Alt.# _____ | MOBILIZATION & DEMOBILIZATION                    |
| REF. NO.     | QUANTITY:  | UNIT OF MEASURE:                                 |
| 1            | 1  | LUMP SUM   |
|              |  | UNIT PRICE                                       |
|              |  | UNIT PRICE EXTENSION (Quantity times Unit Price) |

|              |  |  |
|--------------|--|--|
| DESCRIPTION: | <input checked="" type="checkbox"/> Base Bid or <input type="checkbox"/> Alt.# _____ | STRUCTURE MAINTENANCE                            |
| REF. NO.     | QUANTITY:  | UNIT OF MEASURE:                                 |
| 2            | 1  | LUMP SUM   |
|              |  | UNIT PRICE                                       |
|              |  | UNIT PRICE EXTENSION (Quantity times Unit Price) |

|              |  |  |
|--------------|--|--|
| DESCRIPTION: | <input checked="" type="checkbox"/> Base Bid or <input type="checkbox"/> Alt.# _____ | LEEVE REPAIR                                     |
| REF. NO.     | QUANTITY:  | UNIT OF MEASURE:                                 |
| 3            | 1,174  | LINEAR FOOT                                      |
|              |  | UNIT PRICE                                       |
|              |  | UNIT PRICE EXTENSION (Quantity times Unit Price) |

|              |  |  |
|--------------|--|--|
| DESCRIPTION: | <input checked="" type="checkbox"/> Base Bid or <input type="checkbox"/> Alt.# _____ | DREDGING OF INLET CHANNEL                        |
| REF. NO.     | QUANTITY:  | UNIT OF MEASURE:                                 |
| 4            | 1,120  | LINEAR FOOT                                      |
|              |  | UNIT PRICE                                       |
|              |  | UNIT PRICE EXTENSION (Quantity times Unit Price) |

|              |  |  |
|--------------|--|--|
| DESCRIPTION: | <input checked="" type="checkbox"/> Base Bid or <input type="checkbox"/> Alt.# _____ | CONSTRUCTION SURVEY                              |
| REF. NO.     | QUANTITY:  | UNIT OF MEASURE:                                 |
| 5            | 1  | LUMP SUM   |
|              |  | UNIT PRICE                                       |
|              |  | UNIT PRICE EXTENSION (Quantity times Unit Price) |

|                |   |  |
|----------------|---|--|
| DESCRIPTION:   | <input type="checkbox"/> Base Bid or <input type="checkbox"/> Alt.# _____ |  |
| REF. NO.       | QUANTITY:   | UNIT OF MEASURE:                                 |
| Not Applicable | Not Applicable  | Not Applicable                                   |
|                |   | UNIT PRICE                                       |
|                |   | UNIT PRICE EXTENSION (Quantity times Unit Price) |
|                |   | Not Applicable                                   |

|                |   |  |
|----------------|---|--|
| DESCRIPTION:   | <input type="checkbox"/> Base Bid or <input type="checkbox"/> Alt.# _____ |  |
| REF. NO.       | QUANTITY:   | UNIT OF MEASURE:                                 |
| Not Applicable | Not Applicable  | Not Applicable                                   |
|                |   | UNIT PRICE                                       |
|                |   | UNIT PRICE EXTENSION (Quantity times Unit Price) |
|                |   | Not Applicable                                   |

|                |   |  |
|----------------|---|--|
| DESCRIPTION:   | <input type="checkbox"/> Base Bid or <input type="checkbox"/> Alt.# _____ |  |
| REF. NO.       | QUANTITY:   | UNIT OF MEASURE:                                 |
| Not Applicable | Not Applicable  | Not Applicable                                   |
|                |   | UNIT PRICE                                       |
|                |   | UNIT PRICE EXTENSION (Quantity times Unit Price) |
|                |   | Not Applicable                                   |

**Wording for "DESCRIPTION" is to be provided by the Owner.**  
**All quantities are estimated. The contractor will be paid based upon actual quantities as verified by the Owner.**

**This Page Intentionally Left Blank**

**BID BOND**  
FOR  
**COASTAL PROTECTION AND RESTORATION AUTHORITY PROJECTS**

Date: \_\_\_\_\_

KNOW ALL MEN BY THESE PRESENTS:

That \_\_\_\_\_ of \_\_\_\_\_, as Principal, and \_\_\_\_\_, as Surety, are held and firmly bound unto the State of Louisiana, Coastal Protection and Restoration Authority (Obligee), in the full and just sum of five (5%) percent of the total amount of this proposal, including all alternates, lawful money of the United States, for payment of which sum, well and truly be made, we bind ourselves, our heirs, executors, administrators, successors and assigns, jointly and severally firmly by these presents.

Surety represents that it is listed on the current U. S. Department of the Treasury Financial Management Service list of approved bonding companies as approved for an amount equal to or greater that the amount for which it obligates itself in this instrument or that it is a Louisiana domiciled insurance company with at least an A - rating in the latest printing of the A. M. Best's Key Rating Guide. If surety qualifies by virtue of its Best's listing, the Bond amount may not exceed ten percent of policy-holders' surplus as shown in the latest A. M. Best's Key Rating Guide.

Surety further represents that it is licensed to do business in the State of Louisiana and that this Bond is signed by surety's agent or attorney-in-fact. This Bid Bond is accompanied by appropriate power of attorney.

THE CONDITION OF THIS OBLIGATION IS SUCH that, whereas said Principal is herewith submitting its proposal to the Obligee on a Contract for:

\_\_\_\_\_  
NOW, THEREFORE, if the said Contract be awarded to the Principal and the Principal shall, within such time as may be specified, enter into the Contract in writing and give a good and sufficient bond to secure the performance of the terms and conditions of the Contract with surety acceptable to the Obligee, then this obligation shall be void; otherwise this obligation shall become due and payable.

\_\_\_\_\_  
PRINCIPAL (BIDDER)

\_\_\_\_\_  
SURETY

BY: \_\_\_\_\_  
AUTHORIZED OFFICER-OWNER-PARTNER

BY: \_\_\_\_\_  
AGENT OR ATTORNEY-IN-FACT (SEAL)

**This Page Intentionally Left Blank**

**Name of Project**

**STATE OF LOUISIANA**

**PARISH OF CAMERON**

**ATTESTATIONS AFFIDAVIT**

**Before me**, the undersigned notary public, duly commissioned and qualified in and for the parish and state aforesaid, personally came and appeared Affiant, who after being duly sworn, attested as follows:

**LA. R.S. 38:2227 PAST CRIMINAL CONVICTIONS OF BIDDERS**

A. No sole proprietor or individual partner, incorporator, director, manager, officer, organizer, or member who has a minimum of a ten percent (10%) ownership in the bidding entity named below has been convicted of, or has entered a plea of guilty or nolo contendere to any of the following state crimes or equivalent federal crimes:

- |                                       |                                   |
|---------------------------------------|-----------------------------------|
| (a) Public bribery (R.S. 14:118)      | (c) Extortion (R.S. 14:66)        |
| (b) Corrupt influencing (R.S. 14:120) | (d) Money laundering (R.S. 14:23) |

B. Within the past five years from the project bid date, no sole proprietor or individual partner, incorporator, director, manager, officer, organizer, or member who has a minimum of a ten percent (10%) ownership in the bidding entity named below has been convicted of, or has entered a plea of guilty or nolo contendere to any of the following state crimes or equivalent federal crimes, during the solicitation or execution of a contract or bid awarded pursuant to the provisions of Chapter 10 of Title 38 of the Louisiana Revised Statutes:

- |  |  |
|--|--|
| (a) Theft (R.S. 14:67)                           | (f) Bank fraud (R.S. 14:71.1)                                |
| (b) Identity Theft (R.S. 14:67.16)               | (g) Forgery (R.S. 14:72)                                     |
| (c) Theft of a business record<br>(R.S.14:67.20) | (h) Contractors; misapplication of<br>payments (R.S. 14:202) |
| (d) False accounting (R.S. 14:70)                | (i) Malfeasance in office (R.S. 14:134)                      |
| (e) Issuing worthless checks<br>(R.S. 14:71)     |  |

**LA. R.S. 38:2212.10 Verification of Employees**

- A. At the time of bidding, Appearer is registered and participates in a status verification system to verify that all new hires in the state of Louisiana are legal citizens of the United States or are legal aliens.
- B. If awarded the contract, Appearer shall continue, during the term of the contract, to utilize a status verification system to verify the legal status of all new employees in the state of Louisiana.
- C. If awarded the contract, Appearer shall require all subcontractors to submit to it a sworn affidavit verifying compliance with Paragraphs (A) and (B) of this Subsection.

**HWY 384 HYDROLOGIC RESTORATION PROJECT-MAINTENANCE EVENT**  
**Name of Project**

**CS-21**  
**Project No.**

**LA. R.S. 23:1726(B) Certification Regarding Unpaid Workers Compensation Insurance**

- A. R.S. 23:1726 prohibits any entity against whom an assessment under Part X of Chapter 11 of Title 23 of the Louisiana Revised Statutes of 1950 (Alternative Collection Procedures & Assessments) is in effect, and whose right to appeal that assessment is exhausted, from submitting a bid or proposal for or obtaining any contract pursuant to Chapter 10 of Title 38 of the Louisiana Revised Statutes of 1950 and Chapters 16 and 17 of Title 39 of the Louisiana Revised Statutes of 1950.
- B. By signing this bid /proposal, Affiant certifies that no such assessment is in effect against the bidding / proposing entity.

\_\_\_\_\_  
**NAME OF BIDDER**

\_\_\_\_\_  
**NAME OF AUTHORIZED SIGNATORY OF BIDDER**

\_\_\_\_\_  
**DATE**

\_\_\_\_\_  
**TITLE OF AUTHORIZED SIGNATORY OF BIDDER**

\_\_\_\_\_  
**SIGNATURE OF AUTHORIZED  
SIGNATORY OF BIDDER/AFFIANT**

**Sworn to and subscribed** before me by Affiant on the \_\_\_\_ day of \_\_\_\_\_, 20\_\_ .

\_\_\_\_\_  
Notary Public

**This Page Intentionally Left Blank**



**FOR INFORMATION ONLY**

This document will be prepared by the Coastal Protection and Restoration Authority in the form appropriate for the project.

**CONTRACT BETWEEN OWNER AND CONTRACTOR  
AND PERFORMANCE AND PAYMENT BOND**

This agreement entered into this \_\_\_\_\_ day of \_\_\_\_\_, 2015, by (CONTRACTOR NAME) hereinafter called the "Contractor", whose business address is \_\_\_\_\_, and the State of Louisiana Coastal Protection and Restoration Authority, herein represented by its Executive Director executing this contract, and hereinafter called the "Owner".

Witnesseth that the Contractor and the Owner, in consideration of premises and the mutual covenants; consideration and agreement herein contained, agree as follows:

Statement of Work: The Contractor shall furnish all labor and materials and perform all of the work required to build, construct and complete in a thorough and workmanlike manner:

Project No. \_\_\_\_\_  
State ID No. \_\_\_\_\_ Site Code \_\_\_\_\_

in strict accordance with Contract Documents prepared by Owner.

It is recognized by the parties herein that said Contract Documents, including by way of example and not of limitation, the Plans, Specifications (including General Provisions, Special Provisions, and Technical Specifications), Any Addenda thereto, Instructions To Bidders, this Contract, Advertisement For Bids, Affidavit, Bid Form, Bonds (Bid, Performance, and Payment), any Submitted Post-Bid Documentation, Notice of Award, Notice to Proceed, Change Orders, and Claims, if any, impose duties and obligations upon the parties herein, and said parties thereby agree that they shall be bound by said duties and obligations. For these purposes, all of the provisions contained in the aforementioned Contract Documents are incorporated herein by reference with the same force and effect as though said Contract Documents were herein set out in full.

Time for Completion: The work shall be commenced on a date to be specified in a written order of the Owner and shall be completed within \_\_\_\_\_ consecutive calendar days from and after the said date.

Liquidated Damages: Contractor shall be assessed Liquidated Damages in the amount of \$\_\_\_\_\_ per day for each consecutive calendar day which work is not complete beginning with the first day beyond the completion time.

Compensation to be paid to the Contractor: The Owner will pay and the Contractor will accept in full consideration for the performance of the contract the sum of \_\_\_\_\_ **Dollars (\$)** which sum represents the Contract Price.

Performance and Payment Bond: To these presents personally came and intervened \_\_\_\_\_, herein acting for \_\_\_\_\_, a corporation organized and

existing under the laws of the State of \_\_\_\_\_, and duly authorized to transact business in the State of Louisiana, as surety, who declared that having taken cognizance of this contract and of the Construction Documents mentioned herein, he hereby in his capacity as its Attorney in Fact obligates his said company, as Surety for the said Contractor, unto the said Owner, up to the sum of \_\_\_\_\_ **Dollars (\$)**. By issuance of this bond, the surety acknowledges they are in compliance with R.S. 38:2219.

The condition of this performance and payment bond shall be that should the Contractor herein not perform the contract in accordance with the terms and conditions hereof, or should said Contractor not fully indemnify and save harmless the Owner, from all cost and damages which he may suffer by said Contractor's non-performance or should said Contractor not pay all persons who have and fulfill obligations to perform labor and/or furnish materials in the prosecution of the work provided for herein, including by way of example workmen, laborers, mechanics, and furnishers of materials, machinery, equipment and fixtures, then said Surety agrees and is bound to so perform the contract and make said payment(s).

Provided, that any alterations which may be made in the terms of the contract or in the work to be done under it, or the giving by the Owner of any extensions of time for the performance of the contract, or any other forbearance on the part of either the Owner or the Contractor to the other shall not in any way release the Contractor or the Surety from their liability hereunder, notice to the Surety of any such alterations, extensions or other forbearance being hereby waived.

The Contractor agrees to abide by the requirements of the following as applicable: Title VI and VII of the Civil Rights Act of 1964, as amended by the Equal Opportunity Act of 1972, Federal Executive Order 11246, the Federal Rehabilitation Act of 1973, as amended, the Vietnam Era Veteran's Readjustment Assistance Act of 1974, Title IX of the Education Amendments of 1972, the Age Act of 1972, and Contractor agrees to abide by the requirements of the Americans with Disabilities Act of 1990.

Contractor agrees not to discriminate in its employment practices, and will render services under this contract without regard to race, color, sex, religion, national origin, genetic information, age or disabilities. Any act of discrimination committed by Contractor or failure to comply with these statutory obligations when applicable shall be grounds for termination of this contract.

In Witness whereof, the parties hereto on the day and year first above written have executed this agreement in eight (8) counterparts, each of which shall, without proof or accountancy for the other counterparts, be deemed an original thereof.

**WITNESSES:**

\_\_\_\_\_  
\_\_\_\_\_  
\_\_\_\_\_  
\_\_\_\_\_  
\_\_\_\_\_  
\_\_\_\_\_

**STATE OF LOUISIANA  
COASTAL PROTECTION AND  
RESTORATION AUTHORITY**

BY: \_\_\_\_\_  
Kyle Graham, Deputy Executive Director

BY: \_\_\_\_\_

SURETY: \_\_\_\_\_

BY: \_\_\_\_\_  
ATTORNEY IN FACT

\_\_\_\_\_

\_\_\_\_\_  
ADDRESS

\_\_\_\_\_  
TELEPHONE NUMBER

STATE OF LOUISIANA  
PARISH OF CAMERON

PROJECT NO. CS-21  
NAME: HIGHWAY 384 HYDROLOGIC RESTORATION PROJECT  
MAINTENANCE EVENT  
LOCATION: CAMERON PARISH

**AFFIDAVIT**

Before me, the undersigned authority, duly commissioned and qualified within and for the State and Parish aforesaid, personally came and appeared \_\_\_\_\_ representing who, being by me first duly sworn deposed and said that he has read this affidavit and does hereby agree under oath to comply with all provisions herein as follows:

**PART I.**

Section 2224 of Part II of Chapter 10 of Title 38 of the Louisiana Revised Statutes, as amended.

(1) That affiant employed no person, corporation, firm, association, or other organization, either directly or indirectly, to secure the public contract under which he received payment, other than persons regularly employed by the affiant whose services in connection with the construction, alteration or demolition of the public building or project or in securing the public contract were in the regular course of their duties for affiant; and

(2) That no part of the Contract price received by affiant was paid or will be paid to any person, corporation, firm, association, or other organization for soliciting the Contract, other than the payment of their normal compensation to persons regularly employed by the affiant whose services in connection with the construction, alteration or demolition of the public building or project were in the regular course of their duties for affiant.

**PART II.**

Section 2190 of Part I of Chapter 10 of Title 38 of the Louisiana Revised Statutes, as amended.

That affiant, if an architect or engineer, or representative thereof, does not own a substantial financial interest, either directly or indirectly, in any corporation, firm, partnership, or other organization which supplies materials for the construction of a public work when the architect or engineer has performed architectural or engineering services, either directly or indirectly, in connection with the public work for which the materials are being supplied.

For the purposes of this Section, a "substantial financial interest" shall exclude any interest in stock being traded on the American Stock Exchange or the New York Stock Exchange.

That affiant, if subject to the provisions of this section, does hereby agree to be subject to the penalties involved for the violation of this section.

---

AFFIANT

SWORN TO AND SUBSCRIBED BEFORE ME THIS \_\_\_\_\_ DAY OF \_\_\_\_\_, 2014.

---

NOTARY

**This Page Intentionally Left Blank**

## **PART I GENERAL PROVISIONS**

### **GP-1 DEFINITION OF TERMS**

Whenever used in the Bidding Requirements or Contract Documents and printed with initial capital letters, the terms listed below will have the meanings indicated which are applicable to the singular or plural thereof. In addition to terms specifically defined, terms with initial capital letters in the Contract Documents include references to identified articles and paragraphs and the titles of other documents or forms.

Unless stated otherwise in the Contract Documents, words or phrases which have a well-known technical or construction industry or trade meaning are used in the Contract Documents in accordance with such recognized meaning.

- a. Acceptance: A written approval from the Engineer which certifies that specific items of work in the Contract have been completed and/or obligations have been fulfilled by the Contractor.
- b. Addenda: Those written or graphic documents which are issued prior to opening of Bids in accordance with the Bidding Requirements and clarify or change the bidding requirements or the proposed Contract Documents.
- c. Application of Payment: That form which is used by the Contractor to request partial and final payment and is deemed acceptable to the Owner. It shall be accompanied by any supporting documentation required by the Contract Documents.
- d. A.S.T.M.: American Society for Testing and Materials.
- e. Bid: An offer or proposal submitted on the prescribed form setting forth the prices for the Work.
- f. Bidder: The person, association of persons, firm, or corporation submitting a proposal for the Work.
- g. Bidding Requirements: The Advertisement for Bids, Instructions to Bidders, Form of Bid Security, if any, and Bid Form with any supplements.
- h. Change Order: A written order which is submitted to the Contractor, signed by the Owner, and authorizes an addition, deletion, or revision in the Work, or an adjustment in the contract price or the contract time issued after the effective date of the Contract.
- i. Claim: A written demand or assertion by Owner or Contractor seeking an adjustment of Contract Price or Contract Times, or both or other relief with respect to the terms of the Contract.
- j. Contract: The written agreement between the Owner and the Contractor which defines the work to be completed and shall be understood to also include all Contract Documents.

- k. Contract Documents: The Contract, all addenda which pertains to the Contract Documents, Bid Documents and specified Attachments accompanying the Bid and any post-bid documentation submitted prior to the Notice of Award, Contractor's Bid when attached as an exhibit to the Agreement, the Bonds (Bid and Performance/Payment), General Provisions, Special Provisions, Technical Specifications, Plans, and all Field or Change Orders issued after the execution of the Agreement. Shop Drawings and other submittals by the Contractor are not Contract Documents.
- l. Contract Price: The moneys payable by the Owner to the Contractor for the Work in accordance with the Contract Documents as stated in the Contract.
- m. Contract Time: The number of calendar days specified in the Contract for completion of the Work, together with any extensions authorized through change orders.
- n. Contractor: The person, association of persons, firm, or corporation entering into the duly awarded Contract.
- o. Contracting Agency: The State of Louisiana, Coastal Protection and Restoration Authority (CPRA).
- p. Day: When any period of time is referred to in the Contract Documents using days, it will be computed to exclude the first day and include the last day of such period. If the last day of any such period falls on a Saturday, Sunday, or a legal holiday, that day will be omitted from the computation. A calendar day is measured as twenty-four (24) hour period starting at midnight and ending the following midnight.
- q. Design Report: A written report by the Engineer which provides the design methodology for the Work.
- r. Effective Date of the Contract: The date indicated in the Contract on which it becomes effective.
- s. Engineer: The State of Louisiana, Coastal Protection and Restoration Authority, or its designee.
- t. Equipment: All machinery, implements, and power-tools, in conjunction with the necessary supplies for the operation, upkeep, maintenance, and all other tools and apparatuses necessary for the proper construction and acceptable completion of the Work.
- u. Extension of Contract: Any extension of time for completion of Work beyond the Contract Time which is granted by the Owner, recommended by the Engineer and approved by the Coastal Protection and Restoration Authority in the form of a Change Order.
- v. Federal Sponsor: The federal agency which has been tasked, if applicable, to manage the implementation of the project.
- w. Field Order: A written order issued by the Engineer which requires minor changes in the Work but which does not involve a change in the Contract Price or Contract Time.



- x. Laboratory: The firm, company, or corporation which is used to test materials and is approved for use by the Engineer.
- y. Laws and Regulations; Laws or Regulations: Any and all applicable laws, rules, regulations, ordinances, codes, and orders of any and all governmental bodies, agencies, authorities, and courts having jurisdiction.
- z. Materials: Any substance used in the Work to build structures, but does not include material used in false work or other temporary structures not incorporated in the Work.
- aa. Milestone: A principal event specified in the Contract Documents relating to an intermediated completion date or time prior to the Contract Times.
- bb. Notice of Award: A written notice to the successful Bidder stating that the Bid has been accepted by the Owner and that the successful Bidder is required to execute the Contract and furnish the Payment and Performance Bond and Non-Collusion Affidavit.
- cc. Notice to Proceed: The written notice to the Contractor by the Owner which provides the starting date for the Contract Time.
- dd. Owner: The Owner is the State of Louisiana (State) which acts through the Contracting Agency.
- ee. Performance and Payment Bond: The approved form of security furnished by the Contractor and Surety for the faithful performance of the Work, and the payment for all labor, materials, and/or obligations incurred by the Contractor in the prosecution thereof.
- ff. Plans: That part of the Contract Documents prepared or approved by the Engineer which graphically shows the scope, intent, and character of the Work to be completed by the Contractor.
- gg. Project Site: The location where the Work is to be performed as stated in the Contract Documents.
- hh. Resident Project Representative: An authorized representative of the Engineer who is responsible to inspect the Work and materials furnished by the Contractor.
- ii. Right-of-way: That entire area reserved for constructing, maintaining, and protecting the proposed improvement, structures, and appurtenances of the Work.
- jj. Samples: Physical examples of materials, equipment, or workmanship that are representative of some portion of the Work and which establish the standards by which such portions of the Work will be judged.
- kk. Shop Drawings: All drawings, diagrams, illustrations, schedules, and other data or information which are specifically prepared or assembled by or for the Contractor and submitted by the Contractor to illustrate some portion of the Work to be performed.

- ll. Specifications: That part of the Contract Documents consisting of written technical descriptions of materials, equipment, systems, standards, and workmanship as applied to the work to be performed and certain administrative details applicable thereto.
- mm. State: The State of Louisiana.
- nn. Structures: Bridges, plugs, weirs, bulkheads, berms, dams, levees, and other miscellaneous construction encountered during the Work and not otherwise classified herein.
- oo. Subcontractor: Any person, association of persons, firm, or corporation who contracts with the Contractor to perform any part of the project covered by the Contract.
- pp. Submittals: Certificates, samples, shop drawings, and all other project data which are submitted to the Engineer in order to verify that the correct products will be installed on the project.
- qq. Successful Bidder: The lowest responsible Bidder whom the Owner makes an award.
- rr. Special Provisions: That part of the Contract Documents which amends or supplements these General Provisions.
- ss. Surety: The corporate body, licensed to do business in Louisiana, bound with and for the Contractor's primary liability, and engages to be responsible for payment of all obligations pertaining to acceptable performance of the Work contracted.
- tt. Temporary Structures: Any non-permanent structure required while engaged in the prosecution of the Contract.
- uu. Work: All work specified herein or indicated on the Plans.
- vv. Work Plan: A written plan by the Contractor that details how the Work will be provided including layout drawings, projected schedule (Initial Progress Schedule), and a list of labor hours, materials, and equipment.

## GP-2 BID REQUIREMENTS

The Contract and Bonds which govern the Work shall be performed in accordance with the Plans, Specifications, and the Louisiana Standard Specifications for Roads and Bridges, 2006 edition. The Bidder understands that all quantities for performing the Work have been estimated by the Engineer, and that the Bid shall be the sum of the quantities multiplied by their respective unit rates. The Contract shall be awarded by the Owner through a comparison of all bids. It is the responsibility of each Bidder before submitting a Bid to:

- 2.1. Examine the Bidding Documents including the Plans and Specifications and any Addenda or related data identified in the Bidding Documents;
- 2.2. Visit the Project Site to become familiar with the local conditions if they are believed to affect cost, progress, or the completion of the Work;

- 2.3. Become familiar and satisfied with all federal, state, and local Laws and Regulations that may affect cost, progress, or the completion of the Work;
- 2.4. Study and correlate all information known to the Bidder including observations obtained from Bidder's visits, if any, to the Project Site, with the Bidding Documents;
- 2.5. Submit a written notice to the Engineer within three (3) days regarding any conflicts, errors, ambiguities, or discrepancies discovered in the Bidding Documents and confirm that the written resolution thereof by the Engineer is acceptable to the Bidder; and
- 2.6. Determine that the Bidding Documents are generally sufficient to convey an understanding of all terms and conditions for completing the required Work.

The submission of a Bid will constitute an incontrovertible representation that the Bidder has complied with every requirement of these Specifications. The Bidder shall comply with all other requirements specified in the Advertisement For Bids and the Instruction To Bidders.

### GP-3 AVAILABILITY OF PLANS AND SPECIFICATIONS

One (1) set of Plans and Specifications shall be furnished to each Bidder. Three (3) sets of the Plans and Specifications shall be furnished to the Contractor upon award of the Contract. Additional sets may be furnished to the Contractor upon request from the Engineering Division of the Coastal Protection and Restoration Authority, 450 Laurel Street, 11th Floor, Baton Rouge, Louisiana 70801.

### GP-4 LAWS, REGULATIONS, STANDARDS, SPECIFICATIONS, AND CODES

Bidders are required to become familiar and remain in compliance with all Federal, State, and local laws, ordinances, and regulations and all orders and decrees of bodies or tribunals having any jurisdiction or authority which may affect those employed for the execution of the Work or which may affect the conduct of the Work. The Contractor shall indemnify the Owner and its representatives against any claim or liability arising from all violations of any laws, bylaws, ordinances, codes, regulations, orders, or decrees, whether by the Contractor or by the Contractor's employees. The filing of a bid will be presumptive evidence that the Bidder has complied with this requirement. The Owner will not be responsible for any inaccurate interpretations or conclusions drawn by the Contractor from information and documentation provided by the Owner.

References to standards, specifications, manuals, or codes of any technical society, organization, or association, or to Laws and Regulations, whether such reference be specific or by implication, may not be in effect at the time of opening the Bids (or on the Effective Date of the Contract if there were no Bids), except as may be otherwise specifically stated in the Contract Documents. No provision of any such standard, specification, manual, or code, or any instruction of a supplier shall be effective to change the duties or responsibilities of the Owner or Engineer, or any of their Subcontractors, consultants, agents, or employees from those set forth in the Bid Documents. No such provision shall be effective to assign to the Owner or Engineer, or any of their consultants, agents, or employees any duty or authority to supervise or direct the performance of the Contractor's obligations or any duty or authority to undertake responsibility inconsistent with the provisions of the Contract Documents.

The obligations imposed by these specifications are in addition to and are not to be construed in any way as a limitation of any rights available to the Engineer or Owner which are otherwise imposed by any laws or regulations or other provisions within the Contract Documents.

The Contractor shall abide by laws set forth in the Davis-Bacon Act of 1931 which states that all laborers and mechanics employed by recipients, the recipient's contractors, or subcontractors on this project shall be paid wages at rates no less than those prevailing on projects of a character similar in the locality as determined by the Secretary of Labor in accordance with Subchapter IV of Chapter 31 of Title 40 United States Code. Additionally, with respect to the labor standards specified in this section, the Secretary of Labor shall have the authority and functions set forth in Reorganization Plan Number 14 of 1950 (64 Stat. 1267; 5 U.S.C. App.) and The Copeland Act of Title 40 (40 U.S.C. § 3145). Prevailing Wage Determination Schedules, as determined by the United States Department of Labor, are provided in the Appendix. Prevailing Wage Determination Schedules are subject to modification by the United States Department of Labor. The Contractor is responsible for utilizing the most current Prevailing Wage Determination Schedule. These documents can be downloaded from the following link: <http://www.wdol.gov/dba.aspx#3>. Modifications to Prevailing Wage Determination Schedules shall be effective if received (or posted) no less than 10 days prior to bid opening.

#### GP-5 PRE-BID CONFERENCE AND SITE VISIT

A Pre-Bid Conference will be held at the location and on the date provided in the Advertisement For Bids. If the Pre-Bid Conference is stated in the Advertisement for Bids to be a MANDATORY Pre-Bid Conference, bids shall be accepted only from those bidders who attend the Pre-Bid Conference in its entirety. Failure to attend a mandatory Pre-Bid Conference in its entirety will result in a null or void Bid.

A site visit may also be held at the Project Site as specified in the Advertisement For Bids or at the Pre-Bid conference. If held, bidders will be required to furnish their own transportation to the Project Site. Representatives of the Owner and Engineer will attend the Pre-Bid conference and site visit, if held, to discuss the Work.

All questions shall be in writing and faxed or emailed to the Coastal Protection and Restoration contact person listed in the Advertisement For Bids after the Pre-Bid Conference and by the due date announced at the Pre-Bid conference. In order to ensure adequate response time, all questions and/or requests for clarification or interpretation of the Bid Documents should be received by the Coastal Protection and Restoration Authority at least seven days prior to the date for receipt of bids. Oral statements will not be binding or legally effective. The Coastal Protection and Restoration Authority will issue addenda in response to all questions arising at the Pre-Bid Conference and site visit to all prospective Bidders on record. All prospective Bidders on record may contact the Coastal Protection and Restoration Authority contact person for any additional information.

#### GP-6 NOTICE OF AWARD

The Owner, or its designated bidding agent (Division of Administration, Office of Facility Planning and Control), shall provide written notice to the Successful Bidder stating that the

Owner will sign and deliver the Contract upon compliance with the conditions enumerated therein and within the time specified.

#### GP-7 NOTICE TO PROCEED AND CONTRACT TIME

The Contractor shall start the Work and begin the Contract Time on the dates provided in the Notice to Proceed. The Work shall be conducted using sufficient labor, materials, and equipment as necessary to ensure completion within the Contract Time. The Contract Time for completion of the Base Bid for the Work is provided in the Instructions To Bidders, unless an extension is granted to the Contract Time as specified in GP-44. If the Bid contains an Alternate Bid(s), and the Alternate Bid(s) is awarded and included in the Contract, the Contract Time associated with the Alternate Bid(s) will be as provided in the Special Provisions.

#### GP-8 WORK PLAN

The Contractor shall develop a written Work Plan which accounts for all of the construction activities required by the Contract Documents. The Work Plan shall include a list of the individual construction tasks to be completed and the estimated dates for beginning and completing the tasks. It shall also include all other items which are applicable to completing the Work such as, but not limited to, the following:

- a. Typical report form for the Bi-Weekly Progress Meeting;
- b. Typical form for Daily Progress Report;
- c. Hurricane and Severe Storm Plan;
- d. Site-specific Health and Safety Plan;
- e. The delivery method and source(s) of all construction materials (company or producer name, mailing and physical address, phone number, and name of contact person).
- f. The personnel, material, subcontractors, fabricators, suppliers, types of equipment, and equipment staging areas the Contractor proposes to use for construction;
- g. Shop drawings, test results, and sample submittals;
- h. Survey layout and stakeout;
- i. All supplemental items specified in the Special Provisions.

The Work Plan shall be submitted to the Engineer prior to the Pre-Construction Conference by the date provided in the Special Provisions. The Engineer shall review the Work Plan and have the Contractor make any necessary revisions prior to acceptance of the plan. **No payment for mobilization will be made until the Work Plan has been accepted by the Engineer.**

**GP-9 PROGRESS SCHEDULE**

The Contractor shall develop a written Progress Schedule which provides for an orderly progression of the Work, submittals, tests, and deliveries in order to complete the Work within the specified Milestones and Contract Time. All of the items listed in the Work Plan shall be integrated into the Progress Schedule. The format of the schedule shall be composed using Microsoft Project®, or any other software deemed acceptable by the Engineer. It shall be updated weekly by the Contractor, at a minimum. The Progress Schedule shall also include, but not be limited to the following:

- a. All of the elements in the Work Plan, including updates;
- b. A work order issued from Louisiana One Call ordering all their subscribers in the project area to mark their utilities;
- c. A telephone log verifying that all property owners and utilities have been contacted. This log should list the time, date, and names of the personnel representing the property owners, utilities, and Contractor;

The following table defines the monthly anticipated adverse weather days that are expected to occur during the Contract Time and will constitute the baseline monthly weather time for evaluations. The schedule is based upon National Oceanic and Atmospheric Administration (NOAA) or similar data for the regional geographic area.

| Monthly Anticipated Adverse Weather Calendar Days |      |      |      |     |      |      |      |      |      |      |      |
|---|------|------|------|-----|------|------|------|------|------|------|------|
| Jan.  | Feb. | Mar. | Apr. | May | Jun. | Jul. | Aug. | Sep. | Oct. | Nov. | Dec. |
| 5   | 5    | 4    | 4    | 4   | 5    | 7    | 7    | 5    | 3    | 3    | 4    |

The Progress schedule must reflect these anticipated adverse weather delays on all weather dependent activities. Adverse weather days must prevent Work for fifty percent (50%) or more of the work day and delay work critical to the timely completion of the project. The number of actual adverse weather days shall be calculated chronologically from the first to the last day of each month.

The Progress Schedule shall be submitted to the Engineer prior to the Pre-Construction Conference by the date provided in the Special Provisions. The Engineer shall perform a review and have the Contractor make any necessary revisions prior to acceptance of the schedule. Acceptance will not impose responsibility on the Owner or Engineer for the sequencing, scheduling, or progression of the Work. The Contractor is fully responsible for progression of the Work in order to maintain the compliance with the Progress Schedule.

**GP-10 DAILY PROGRESS REPORTS**

The Contractor shall record the following daily information on Daily Progress Reports:

- a. Date and signature of the author of the report;
- b. Dollar amount of all bid items that are fabricated, installed, backfilled, pumped, constructed, damaged, replaced, etc. The amount of material shall be expressed in the units stated in the bid;

- c. Field notes of all surveys;
- d. Notes on all inspections;
- e. Details of Health and Safety meetings;
- f. A brief description of any Change Orders, Field Orders, Claims, Clarifications, or Amendments;
- g. Condition of all navigation aides (I.E., warning signs, lighted marker buoys) and any repairs performed on them;
- h. Weather conditions (adverse weather day, wind speed and direction, temperature, wave height, precipitation, etc.);
- i. The amount of time lost to severe weather or personnel injury, etc;
- j. Notes regarding compliance with the Progress Schedule;
- k. Visitor log (Instructions for format will be furnished by the Field Engineer).

The daily progress reports shall be submitted to the Engineer at the Bi-Weekly Progress Meetings specified in GP-13 in both hard copy and digital format (Adobe Acrobat® Format, or approved equal). The typical form for Daily Progress Reports shall be developed by the Contractor and incorporated into the Work Plan.

#### GP-11 HURRICANE AND SEVERE STORM PLAN

The Contractor shall develop and maintain a written Hurricane and Severe Storm Plan. The Plan shall include, but not be limited to, the following:

- a. What type of actions will be taken before storm strikes at the Project Site. The plan should specify what weather conditions or wave heights will require shutdown of the Work and removal of equipment, personnel, etc.
- b. Notes from continuous monitoring of NOAA marine weather broadcasts and other local commercial weather forecasts.
- c. Equipment list with details on their ability to handle adverse weather and wave conditions.
- d. List of safe harbors or ports and the distance and travel time required to transfer equipment from the Project Site.
- e. Hard copies of any written approvals or operations schedules associated with the use of the safe harbors or ports.
- f. Method of securing equipment at the safe harbors or ports.

- g. List of tug boats and work boats and their respective length, horsepower, etc. which will adequately transfer the equipment to safe harbor or port under adverse weather conditions.
- h. Methods which will be used to secure equipment left onsite during adverse weather conditions.
- i. Evacuation or immediate reaction plans to be taken by personnel for sudden storm occurrences.
- j. Operations procedures which will be used to secure critical dredging equipment such as spuds, swing wires, anchor wires, or tugs during adverse weather conditions.
- k. Communications protocol with local law enforcement and fire and rescue agencies.

The Contractor shall incorporate the Hurricane and Severe Storm Plan into the Work Plan. The Owner and Engineer are not responsible for the adequacy of this plan.

#### GP-12 HEALTH AND SAFETY PLAN AND INSPECTIONS

The Contractor shall develop and maintain a written Health and Safety Plan which allows the Work to be performed in compliance with all applicable laws, ordinances, rules, and regulations of any government agency having jurisdiction over the safety of personnel or property. This includes maintaining compliance with the Code of Federal Regulations, Title 29, Occupational Safety and Health Administration (OSHA) and all applicable Health and Safety Provisions of the State of Louisiana.

The Contractor shall institute a daily inspection program to assure that the requirements of the Health and Safety Plan are being fulfilled. Inspections shall include the nature of deficiencies observed, corrective action taken or to be taken, location of inspection, date, and signature of the person responsible for its contents. The results of the inspections shall be recorded on Daily Progress Reports and kept at the Project Site during the Work.

The Contractor shall incorporate the Health and Safety Plan into the Work Plan. The Owner and Engineer are not responsible for the adequacy of this plan.

#### GP-13 PROGRESS MEETINGS AND REPORTS

The Engineer shall schedule meetings to review the progress of the Work, coordinate future efforts, discuss compliance with the Progress Schedule and resolve miscellaneous problems. The Engineer or Resident Project Representative, Contractor, and all Subcontractors actively working at the Project Site shall attend each meeting. Representatives of suppliers, manufacturers, and other Subcontractors may also attend at the discretion of the Contractor. The Contractor shall record the details of each meeting in a Progress Report. The format of this report shall be developed by the Contractor, approved by the Engineer, and included in the Work Plan. The progress meetings and reports shall be scheduled according to the Special Provisions.



#### GP-14 PRE-CONSTRUCTION CONFERENCE

A Pre-Construction Conference shall be held by the Contractor, Owner, Engineer, local stakeholders, and other appropriate personnel prior to starting construction on the date specified in the Special Provisions. This conference shall serve to establish a mutual understanding of the Work to be performed, the elements of the Progress Schedule and Work Plan, expectations for bi-weekly progress meetings, the Plans and Specifications, processing Applications for Payment, and any other items of concern. If any subcontractors are not present, another pre-construction conference will be required.

#### GP-15 CONTRACT INTENT

The Bid Documents are complementary; what is called for by one is as binding as if called for by all. Clarifications and interpretations or notifications of minor variations and deviations of the Contract Documents will be issued by Engineer as provided in these Specifications. Any labor, documentation, services, materials, or equipment that may reasonably be inferred from the Bid Documents or from prevailing custom or trade usage as being required to produce the intended result will be provided at no additional cost to the Owner.

#### GP-16 ENGINEER AND AUTHORITY OF ENGINEER

The Engineer will be the designated representative of the Owner, the initial interpreter of the Contract Documents and the judge over acceptability of all the Work. Claims, disputes, and other matters relating to the acceptability of the Work, performance by the Contractor or the interpretation of the requirements of the Contract Documents must be submitted to the Engineer in writing. Upon written request from the Contractor, the Engineer shall issue written clarifications or interpretations which are consistent with the overall intent of the Contract Documents. Such written clarifications and interpretations will be binding on the Owner and the Contractor. Either the Owner or the Contractor may make a Claim if a written clarification or interpretation justifies an adjustment in the Contract Price or Contract Times.

The Engineer has the authority to suspend the Work in whole or in part due to failure of the Contractor to correct conditions unsafe for workmen or the general public, carry out provisions of the Contract, perform conformance work, or to carry out orders. The Engineer shall submit a written order to the Contractor for work which must be suspended or resumed. Nothing in this provision shall be construed as establishing responsibility on the part of the Engineer for safety which is the responsibility of the Contractor.

The Engineer or Resident Project Representative shall keep a daily record of weather and flood conditions and may suspend the Work as deemed necessary due to periods of unsuitable weather, conditions considered unsuitable for execution of the Work, or for any other condition or reason deemed to be in the public interest.

#### GP-17 CONFORMITY WITH PLANS AND SPECIFICATIONS

All work and materials involved with the Work shall conform with the lines, grades, cross sections, dimensions, and other requirements shown on the Plans or indicated in these Specifications unless otherwise approved by the Engineer.

## GP-18 CLARIFICATIONS AND AMENDMENTS TO CONTRACT DOCUMENTS

The Contract Documents may be clarified or amended by the Engineer to account for additions, deletions, and revisions to the Work after the Effective Date of the Contract. The clarifications and amendments shall be addressed by either a Change Order or a written clarification by the Engineer. The Contractor shall not proceed with the Work until the Change Order or clarification has been issued by the Engineer. The Contractor shall not be liable to the Owner or Engineer for failure to report any such discrepancy unless the Contractor had reasonable knowledge.

The Contractor may request a clarification or amendment for the following:

- a. Any conflict, error, ambiguity, or discrepancy within the Contract Documents; or
- b. Any conflict, error, ambiguity, or discrepancy between the Bid Documents and the provision of any Law or Regulation applicable to the performance of the Bid; or
- c. Any standard, specification, manual, or code (whether or not specifically incorporated by reference in the Bid Documents); or
- d. Instructions by a supplier.

The official form for a written clarification is provided in Appendix B. This form shall be filled out appropriately by the Contractor and submitted to the Engineer. The Engineer shall clarify the issue in writing on either the clarification form, Field Order or a Change Order and submit it to the Contractor.

## GP-19 SUBCONTRACTS

The Contractor shall provide the names of all Subcontractors to the Engineer in writing before awarding any Subcontracts. The Contractor shall be responsible for the coordination of the trades and Subcontractors engaged in the Work. The Contractor is fully responsible to the Owner for the acts and omissions of all the Subcontractors. The Owner and Engineer will not settle any differences between the Contractor and Subcontractors or between Subcontractors. The Contractor shall have appropriate provisions in all Subcontracts to bind Subcontractors to the Contractor by the terms of the General Provisions and other Contract Documents, as applicable to the Work of Subcontractors. The provisions should provide the Contractor the same power regarding termination of Subcontracts that the Owner may exercise over the Contractor under any provisions of the Contract Documents.

## GP-20 WORKERS, METHODS, AND EQUIPMENT

The Contractor shall provide competent, qualified, and trained personnel to perform the Work. The Contractor shall not employ any person found objectionable by the Engineer. Any person employed by the Contractor or any Subcontractor who, in the opinion of the Engineer, does not perform the Work in a proper, skillful, and orderly manner shall be immediately removed upon receiving a written order by the Engineer. The Engineer may also suspend the Work until the Contractor removes the employee or provides a suitable replacement. Such an employee shall not be re-employed in any portion of the Work without written approval from the Engineer.

The on-site superintendent for the Contractor shall be competent, English-speaking, and qualified to receive orders, supervise, and coordinate all Work for the Contractor and any Subcontractors. The qualifications of the superintendent must be established and approved by the Engineer prior to commencement of the Work. The superintendent shall be furnished by the Contractor regardless of how much Work may be sublet. In the performance of the Work under this Contract, the Contractor shall conduct operations to avoid interference with any other Contractors.

All equipment, products, and material incorporated into the Work shall be as specified, or if not specified, shall be new, of good quality, and protected, assembled, used, connected, applied, cleaned, and conditioned in accordance with the manufacturer's instructions, except as otherwise may be provided in the Bid Documents. All equipment shall be of sufficient size and mechanical condition to meet the requirements of the Work and produce a satisfactory quality of work. Equipment shall not damage adjacent property throughout the performance of the Work. The Plant and Equipment Schedule should be completed by the Contractor.

The Contractor shall be solely responsible for the means, methods, techniques, sequences, and procedures used to complete the Work in conformance with the Contract Documents.

The Contractor shall obtain permission from the Engineer if a method or type of equipment other than specified in the Contract is desired. The request shall be in writing and shall include a full description of the methods, equipment proposed, and reasons for the modification. A proposed item of material or equipment may be considered by the Engineer to be functionally equal to an item specified in the Contract if:

- a. It is at least equal in quality, durability, appearance, strength, and design characteristics;
- b. There is no increase in any cost including capital, installation, or operating to the Owner;
- c. The proposed item will conform substantially, even with deviations, to the detailed requirements of the item named in the Bid Documents.

If, after trial use of the substituted methods or equipment, the Engineer determines that the Work produced does not meet Contract requirements, the Contractor shall discontinue use of the substituted methods or equipment and shall complete the Work with the specified methods and equipment. The Contractor shall remove the deficient Work and replace it with Work of specified quality or take other corrective action as directed. No change will be made in basis of payment for construction items involved or in Contract Time as a result of authorizing a change in methods or equipment.

## GP-21 ACCIDENT PREVENTION, INVESTIGATIONS, AND REPORTING

The Contractor shall be responsible to develop and maintain all safeguards and safety precautions necessary to prevent damage, injury, or loss throughout the performance of the Work. All accidents at the Project Site shall be investigated by the immediate supervisor of employee(s) involved and reported to the Engineer or Resident Project Representative within one (1) working day. A complete and accurate written report of the accident including estimated lost time days shall be submitted to the Engineer within four (4) calendar days. A

follow-up report shall be submitted to the Engineer if the estimated lost time days differ from the actual lost time days.

#### GP-22 PRESERVATION AND RESTORATION OF PROPERTY, MONUMENTS, ETC.

The Contractor shall comply with all applicable laws, ordinances, rules, and regulations of any government agency having jurisdiction over the preservation and protection of public and private property. The Contractor shall install and maintain suitable safeguards and safety precautions during the Work as necessary to prevent damage, injury, or loss to property. This responsibility shall remain with the Contractor until the Work has been completed and accepted. Any damage, injury, or loss to property which is caused by the Contractor or Subcontractors shall be repaired or replaced at the expense of the Contractor.

The Contractor shall protect all land monuments, State and United States bench marks, geodetic and geological survey monuments, and property markers from disturbance or damage until an authorized agent has witnessed or otherwise referenced their location. The Contractor shall also provide protection for all public and private property including trees, utilities, pipes, conduits, structures, etc. These items shall not be removed unless directed by the Engineer.

The Contractor shall be responsible to completely repair all damages to public or private property due to any act, omission, neglect, or misconduct in the execution of the Work unless it is due to unforeseeable causes beyond the control of and without the fault or negligence of the Contractor, including but not restricted to acts of God, public enemies, or governmental authorities. The damage must be repaired at the expense of the Contractor before final acceptance of the Work can be granted by the Engineer. If the Contractor fails to repair the damage within forty-eight (48) hours, the Owner may independently proceed with the repairs at the expense of the Contractor by deducting the cost from the Contract. If the Contractor cannot provide for the cost of repairs, the Surety of the Contractor shall be held until all damages, suits, or claims have been settled.

#### GP-23 PROTECTION OF THE WORK, MATERIALS, AND EQUIPMENT

It shall be the responsibility of the Contractor to protect the Work, materials, and equipment from damages or delays due to inflows, tidal rise, and storm water runoff which may occur at the Project Site. The Owner shall not be held liable or responsible for these types of delays or damages.

#### GP-24 LAND RIGHTS

The Owner has been granted all of the temporary easements, servitudes, and right-of-way agreements from public and private landowners in order to perform the Work. A land rights memorandum which lists all known responsible contacts and required stipulations is provided in Appendix C. The Contractor is responsible to notify all of the contacts and abide by stipulations listed in that memorandum.

## GP-25 UTILITIES

The Owner has been granted all of the temporary easements, servitudes, and right-of-way agreements from known public and private utilities in order to perform the Work. The utilities include, but are not limited to telephone, telegraph, power poles or lines, water or fire hydrants, water or gas mains and pipelines, sewers, conduits, and other accessories or appurtenances of a similar nature which are fixed or controlled by a city, public utility company or corporation.

The Contractor shall conduct the Work in such a manner as to cooperate and minimize inconveniences with utilities. Prior to commencement of the Work, the Contractor is responsible to notify all of the utilities and abide by stipulations required by the utility company(s). The Contractor shall also call Louisiana One Call at 1-800-272-3020 a minimum of 5 working days prior to construction to locate existing utilities at the Project Site.

Any damage to utilities that is caused by the Contractor within the Project Site shall be repaired at the expense of the Contractor. The Owner will not be responsible for any delay or damage incurred by the Contractor due to working around or joining the Work to utilities left in place or for making adjustments.

Any unidentified pipes or structures which may be discovered within the limits of the Project Site shall not be disturbed and shall be reported to the Engineer as soon as possible. Construction or excavation shall not be performed around unidentified utilities without prior approval from the Engineer.

## GP-26 PERMITS

Federal and State permits that are required to perform the Work, such as the Department of the Army Permit, Coastal Use Permit, LDEQ Clean Water Permit, LDWF Fill Material License, and LADOTD highway crossing permit have been secured by the Owner. Permit conditions affecting the construction processes have been included in these Specifications. Copies of these permits will be provided to the Contractor at the pre-construction conference. These permits will not relieve the responsibility of the Contractor from obtaining any additional permits which may be needed to complete the Work. Copies of any special permits that are obtained by the Contractor must be submitted to the Owner. The Contractor shall conform to the requirements therein and display copies of the permits in a public setting at the Project Site at all times.

## GP-27 PROJECT SITE CLEAN-UP

The Contractor shall keep the Project Site free from accumulations of waste material or trash at all times. All trash and waste materials shall be removed by the Contractor and disposed off-site in an approved waste disposal facility. In addition, all equipment, tools, and non-conforming work shall also be removed prior to the Work being accepted. No materials shall be placed outside of the Project Site.

#### GP-28 OWNER INSPECTION

The Owner, Resident Project Representative, and Federal Sponsor shall have the right to perform reasonable inspections and testing of the Work at the Project Site. Access shall be granted to the entire Project Site including all materials intended for use in the Work. The Contractor shall allow reasonable time for these inspections and tests to be performed. The inspections shall not relieve the Contractor from any obligation in accordance with the requirements of the Contract.

The Owner shall notify the Contractor prior to all tests, inspections, and approvals of the Work which are to be conducted at the Project Site. The Owner shall also provide the Contractor with the written results of all inspections and tests. Inspections, tests, or Payments made by the Owner shall not constitute acceptance of non-conforming Work of prejudice the Owner's rights under the Contract.

#### GP-29 DUTIES OF RESIDENT PROJECT REPRESENTATIVE

A Resident Project Representative shall be assigned by the Engineer to the Project Site to observe the Contractor and monitor the progress and manner in which the Work is being performed. The Resident Project Representative will also report to the Engineer and Contractor whenever materials or Work fail to comply with the Contract. The Resident Project Representative is authorized to reject any materials or suspend work which does not comply with the Contract until the issue is resolved by the Engineer.

However, the Resident Project Representative is not authorized to revoke, alter, enlarge, relax, or release any requirements of the Contract, or to approve or accept any portion of the Work, or to issue instructions contrary to the Plans and Specifications. The Resident Project Representative shall not manage or perform duties for the Contractor.

#### GP-30 CONSTRUCTION STAKES, LINES, AND GRADES

The Engineer shall direct the Contractor to all control points necessary for setting stakes and establishing lines and grades as shown on the Plans. The Contractor shall be responsible for laying out all of the Work. All layouts shall be witnessed and verified by the Engineer or Resident Project Representative prior to beginning the Work. The Contractor shall be responsible for proper execution of the Work according to the layouts after receiving verification from the Engineer.

The Contractor shall be responsible for furnishing and maintaining stakes such that the Work can be verified for acceptance. The Engineer may suspend the Work at any time if it cannot be adequately verified due to the number, quality, or condition of the stakes.

### GP-31 CONTRACTOR'S RESPONSIBILITY FOR WORK

The Contractor shall execute all items covered by the Contract, and shall furnish, unless otherwise definitely provided in the Contract, all materials, implements, machinery, equipment, tools, supplies, transportation, and labor necessary to complete the Work. The Contractor shall pay constant attention to the progress of the Work and shall cooperate with the Engineer in every way possible. The Contractor shall maintain a complete copy of the Contract at all times, including the Plans, Specifications, and any authorized modifications.

### GP-32 ENVIRONMENTAL PROTECTION

The Contractor shall comply with and abide by all federal, state, and local laws and regulations controlling pollution of the environment, including air, water, and noise. The Contractor shall take precautions to prevent pollution of waters and wetlands with fuels, oils, bituminous materials, chemicals, sewage, or other harmful materials and contaminants, and to prevent pollution of the atmosphere from particulate and gaseous matter, in accordance with all terms and conditions of federal, state, and local air and water pollution control laws and programs and their rules and regulations, including the federal Clean Air Act and the federal Clean Water Act.

The Contractor shall adhere to the provisions which require compliance with all standards, orders, or requirements contained under Section 306 of the Clean Air Act and Section 508 of the Clean Water Act, which prohibit the use under non-exempt Federal contracts, grants, or loans, of facilities included on the Environmental Protection Agency (EPA) list of Violating Facilities.

Construction operations in rivers, streams, lakes, tidal or coastal waters, reservoirs, canals, wetlands, and any other impoundments shall be restricted to areas where it is necessary to accomplish the Work and performed in accordance with any applicable federal, state, and local laws, regulations, permit requirements, and guidelines, and the Contractor shall conduct the Work in a manner that will not cause damaging concentrations of silt or pollution to water.

Contractor shall maintain and operate equipment to minimize noise, dust, and vibration near noise, dust and vibration-sensitive areas such as churches, hospitals, schools, and residential areas, and assure that any activities conducted near such areas are not unduly disruptive. Contractor shall maintain all equipment with properly functioning mufflers.

The Contractor shall be responsible for determining and utilizing any erosion and pollution control features or methods that may be necessary to comply with all federal, state, and local laws and regulations.

### GP-33 SANITARY PROVISION

The Contractor shall provide and maintain sanitary accommodations for use by all employees and Subcontractors. Facilities shall comply with the requirements of the Louisiana State Board of Health and Hospitals and other authorities having jurisdiction. Committing public nuisance on the Project Site is prohibited.

#### GP-34 PAYMENT OF TAXES

The Contractor shall be responsible for all taxes and duties that maybe levied under existing State, Federal, and local laws during the completion of the Work. The Owner will presume that the amount of such taxes is included in the unit prices bid by the Contractor and will not provide additional reimbursement.

#### GP-35 RADIO AND TELEPHONES

The Contractor shall furnish and maintain radio and telephone equipment throughout the Contract Time which will allow communication between the Contractor and the Engineer or Resident Project Representative.

#### GP-36 NAVIGATION

All marine vessels shall comply with the following Federal Laws and Regulations:

- a. The International Navigational Rules Act of 1977 (Public Law 95-75, 91 Stat. 308, or 33 U.S.C. 1601-1608); and
- b. The Inland Navigation Rules Act of 1980 (Public Law 96-591, 94 Stat. 3415, 33 U.S.C. 2001-2038).

These rules can be found on the Internet at:  
<http://www.navcen.uscg.gov/?pageName=navRulesContent>.

All marine vessels shall display the lights and day shapes required by Part C- Lights and Shapes of the Inland Navigation Rules. The location, type, color, and size of the lights and day shape shall be in accordance with Annex I - Positioning and Technical Details of Lights and Shapes. Any vessel engaged in dredging is considered a "Vessel restricted in her ability to maneuver" and shall display all the lights and shapes required in Rule 27, "Vessel Not Under Control."

#### GP-37 OBSTRUCTION TO NAVIGATION

The Contractor shall minimize all obstructions to navigation in compliance with pertinent U. S. Coast Guard regulations while conducting the Work. The Contractor shall promptly move any floating equipment or marine vessels which obstruct safe passage of other marine vessels. Upon completion of the Work, the Contractor shall remove all marine vessels and other floating equipment such as temporary ranges, buoys, piles, and other marks or objects that are not permanent features of the Work.

#### GP-38 MARINE VESSELS AND MARINE ACTIVITIES

All marine vessels regulated by the USCG shall have the required USCG documentation that is current before being placed in service. A copy of any USCG Form 835 issued to the vessel in the preceding year shall be made available to the Owner and Engineer and a copy shall be on board the vessel. All officers and crew shall possess valid USCG licenses as required by USCG regulations. These certificates, classifications, and licenses shall be posted in a public area on board each vessel.



All dredges and quarter boats not subject to USCG inspection and certification or not having a current ABS classification shall be inspected in the working mode annually by a marine surveyor accredited by the National Association of Marine Surveyors (NAMS) or the Society of Accredited Marine Surveyors (SAMS) and having at least 5 years' experience in commercial marine plant and equipment. The inspection certificate shall be posted in a public area on board each dredge and/or quarter boat.

All other plant and support vessels shall be inspected before being placed in service and at least annually by a qualified person. The inspection certificate shall be posted in a public area on board each plant and/or vessel.

#### GP-39 RECORD KEEPING

The Contractor shall maintain orderly records of the Progress Schedule, Daily Progress Reports, Progress Meetings, correspondence, submittals, reproductions of original Contract Documents, Change Orders, Field Orders, certificates, additional drawings issued subsequent to the executed Contract, clarifications and interpretations of the Contract Documents by the Engineer, and other related documents at the Project Site until all of the Work is accepted by the Engineer.

#### GP-40 CERTIFICATES OF COMPLIANCE

Any certificates required for demonstrating proof of compliance of materials with specification requirements shall be executed in three (3) copies. Each certificate shall be certified by an authorized agent of the supplying company and shall contain the name and address of the Contractor, the project name and location, and the quantity and date of shipment. Copies of laboratory test reports submitted with certificates shall contain the name and address of the testing laboratory and the testing date. The Contractor shall also certify that all materials and test reports conform to the requirements of the Contract. Certification shall not be construed as relieving the Contractor from furnishing satisfactory material if the material is tested and determined to be in nonconformance.

#### GP-41 SUBMITTALS

The Contractor shall review all Submittals for compliance with the requirements of the Contract prior to delivery to the Engineer. Each Submittal shall contain a signed statement by the Contractor that it complies with the Contract requirements with any exceptions explicitly listed. The Contractor shall comply with these requirements for Submittals from Subcontractors, manufacturers, and suppliers.

All Submittals shall include sufficient data to demonstrate that the requirements of the Contract are met or exceeded. All submittals shall be legible and marked with the project title and clearly identify the item submitted. Each submittal package shall include an itemized list of the items submitted.

All Submittals will be reviewed within fourteen (14) days after being received by the Engineer. The Contractor shall allow the Engineer sufficient time for review, corrections, and resubmission of all Submittals prior to beginning the associated Work. The Contract Time shall not be extended based on incorrect or incomplete Submittals.

## GP-42 CLAIMS FOR EXTRA COST

The Contractor is expected to complete the Work according to the Contract Price specified in the Bid Documents. If the Contractor deems additional compensation is due for work, materials, delays or other additional costs/or expenses not covered in the Contract or not ordered as extra work, the Contractor shall give the Engineer written notice thereof within fourteen (14) calendar days after the receipt of such instructions and, in any event, before commencing the procedure. The Contractor shall justify the claim for extra cost by providing supporting data and calculations. The Engineer shall determine whether the Contractor is entitled to be compensated for such extra cost and shall make any required adjustments of the Contract in accordance with GP-43. If no written claim is made within this fourteen (14) calendar-day period, the Contractor will be deemed to have waived any claim for extra cost for such work.

Claim for damages or delays of the Work shall not be made by the Contractor for a relocation of the construction operation or portions thereof to other locations within the geographical scope of the project, when in the opinion of the Engineer, such relocation is necessary for the most effective prosecution of the Work and may be accomplished without undue hardship.

## GP-43 ALTERATION OF THE CONTRACT AND COMPENSATION

Using Change Orders, Field Orders, or Written Amendments, the Owner may order extra work or make changes by altering the details of construction, add to or deduct from the Work. The requirements and stipulations of these documents shall be binding on the Owner and Contractor throughout the remainder of the Contract. Any claim for an extension of Contract Time caused thereby shall be adjusted at the time of ordering such change.

The value of any such extra work or change shall be determined in one or more of the following ways and in the following priority:

- a. By application of the unit prices in the Contract to the quantities of the items involved or subsequently agreed upon; or
- b. By mutual acceptance between the Owner and Contractor of a lump sum.

If none of the above methods is agreed upon, the Contractor, provided he is so ordered by the Owner in writing, shall proceed with the Work on a "force account" basis. In such a case, the Contractor shall keep and preserve in such form as the Engineer may direct, a correct itemized account of the direct cost of labor, materials, equipment, together with vouchers bearing written certification by the Contractor. In any case, the Engineer shall certify to the amount, including an allowance of fifteen percent (15%) for jobsite and home office overhead indirect expenses and profit due to the Contractor. Where such change involves a subcontractor, an allowance of fifteen percent (15%) for overhead and profit shall be due the subcontractor and an allowance of ten percent (10%) shall be due the Contractor. Pending final determination of value, payments on account of changes shall be made on the Engineer's estimate and as approved in an executed Change Order.

If the Contractor is prevented from completing the Work according to the Contract Price due to the Owner, the Contractor may be entitled to any reasonable and necessary addition of cost as determined by the Engineer. Neither the Owner nor the Contractor shall be entitled to any

damages arising from events or occurrences which are beyond their control, including but not limited to fires, floods, epidemics, abnormal weather conditions, acts of God, acts of war, and other like matters. The provisions of this section exclude recovery for damages caused by the Contractor and compensation for additional professional services by either party.

#### GP-44 EXTENSION OF CONTRACT TIME

The Contractor is expected to complete the Work within the Contract Time specified in the Bid Documents. A legitimate increase of the Contract time may be requested by the Contractor throughout the course of the Work. This Claim must be submitted to the Engineer in writing within fourteen (14) days of the event which caused the time delay to the Contractor. If an extension of Contract Time involves an increase in Contract Price, both claims shall be submitted together. The Contractor shall justify the increase of the Contract Time in the Claim using supporting data and calculations. The Engineer may deny the claim if there is insufficient information to make a determination. If the Claim is approved, the Engineer shall issue a Change Order within thirty (30) days of the Claim. The Contract Time shall be increased on a basis that is commensurate with the amount of additional or remaining Work. For example, the Contract Time can be increased where the number of actual adverse weather days exceeds the number of days estimated in the Contract.

#### GP-45 OWNER'S RIGHT TO TERMINATE CONTRACT FOR CAUSE OR CONVENIENCE

##### 45.1 TERMINATION FOR CAUSE

The Owner shall submit a written notice to the Contractor and Surety which justifies placement of the Contractor in default if:

- a. The Work is not begun within the time specified in the Notice to Proceed; or
- b. The Work is performed with insufficient workmen, equipment, or materials to assure prompt completion; or
- c. The Contractor performs unsuitable, neglected or rejected work, refuses to remove materials; or
- d. The Work is discontinued; or
- e. The Work is not completed within the Contract Time or time extension; or
- f. Work is not resumed within a reasonable time after receiving a notice to continue;  
or
- g. The Contractor becomes insolvent or is declared bankrupt, or commits any act of bankruptcy or insolvency; or
- h. The Contractor allows any final judgment to stand unsatisfied for a period of ten (10) days; or
- i. The Contractor makes an assignment for the benefit of creditors; or

j. The Work is not performed in an acceptable manner.

If the Contractor or Surety does not remedy all conditions cited in the written notice within ten (10) days after receiving such a notice, the Contractor will be in default and the Owner shall remove the Contractor from the Work. If the Contractor is placed into default, the Owner may obtain the necessary labor, materials, and equipment or enter into a new Contract in order to complete the Work. All costs incurred by the Owner for completing the Work under the new Contract will be deducted from the payment due the Contractor. If the expense exceeds the sum payable under the Contract, the Contractor and Surety shall be liable to pay the Owner the difference.

#### 45.2 TERMINATION FOR CONVENIENCE

Owner may, at any time, terminate this Contract or any portion thereof, for Owner's convenience, upon providing written notice to the Contractor. In such case, Contractor shall be paid for all work completed through the date notice was provided (less payments already received) and reasonable demobilization and restocking charges incurred and reasonable overhead and profit based upon industry standards on the work performed. In no event shall the Contractor be entitled to payment of overhead and profit on work not performed. In the event it is determined that the Contractor was wrongfully terminated for cause, pursuant to Section GP 45.1 above, such termination shall be automatically converted to a termination for convenience under and payment made as provided under this Section.

#### GP-46 TEMPORARY SUSPENSION OF WORK

The Engineer shall have the authority to temporarily suspend the Work in whole or in part. A Field Order shall be issued to the Contractor for any of the Work that is suspended for periods exceeding one (1) calendar day. The Field Order shall include the specific reasons and details for the suspension. The Contract Time shall not be extended if the Work is suspended due to failure by the Contractor to comply with a Field Order or with the Plans and Specifications. If the Work is suspended in the interest of the Owner, the Contractor shall make due allowances for the lost time.

#### GP-47 NON-CONFORMING AND UNAUTHORIZED WORK

Work not conforming to the Plans, Specifications, Field Orders, or Change Orders shall not be accepted for payment. Unacceptable or unauthorized work shall be removed and replaced in an acceptable manner at the expense of the Contractor in order to obtain final acceptance of the Work.

If the Contractor should neglect to prosecute the work properly or fail to perform any provision of this Contract, the Owner after seven (7) calendar days written notice to the Contractor, may correct such deficiencies itself or by use of other contractors without prejudice to any other remedy it may have, and may deduct the cost thereof from the payment then or thereafter due to the Contractor.

#### GP-48 CONTRACTOR'S RIGHT TO TERMINATE CONTRACT

The Contractor may terminate the Contract or Work and recover payment from the Owner for labor and materials if the Work is stopped through no act or fault of the Contractor for more than three (3) months. For example, such an occurrence could be caused by a court order or other public authority. In any case, the Contractor shall submit a written notice to the Engineer at the beginning of the occurrence, and a written Claim to the Owner at the end of the occurrence.

#### GP-49 BREACH OF CONTRACT

The Owner shall submit a written Claim to the Contractor regarding any breach of the Contract. The Contractor must provide a written response to the Owner regarding the breach of Contract within ten (10) days after the Claim. This response must provide either an admission to the Claim or a detailed denial based on relevant data and calculations. The failure of the Contractor to provide a proper response within ten (10) days shall result in justification of the Claim by default.

#### GP-50 NO WAIVER OF LEGAL RIGHTS

The Owner shall not be prevented from recovering costs from the Contractor, Surety, or both due to failure of the Contractor to fulfill all of the obligations under the Contract. If a waiver is provided to the Contractor for a breach of Contract by the Owner, it shall not apply to any other breach of Contract. Final acceptance of the Work shall not prevent the Owner from correcting any measurement, estimate, or certificate. The Contractor shall be liable to the Owner without prejudice to the terms of the Contract or any warranty for latent defects, fraud, or gross negligence.

#### GP-51 LIABILITY FOR DAMAGES AND INJURIES

To the fullest extent permitted by Laws and Regulations, the Contractor shall indemnify and hold harmless the Owner, Engineer, and their officers, employees, representatives, and/or agents from all suits, actions, claims, costs, losses, demands, and judgments (including but not limited to fees and charges of engineers, architects, attorneys, and other professionals and all court or arbitration or other dispute resolution costs) brought because of injuries or damage sustained by a person or property due to the operations of Contractor; due to negligence in safeguarding the Work, or use of unacceptable materials in constructing the Work; or any negligent act, omission, or misconduct of the Contractor; or claims or amounts recovered under the Workmen's Compensation Act or other law, ordinance, order, or decree; any money due the Contractor as considered necessary by the Owner for such purpose may be retained for use of the State or in case no money is due, the performance and payment bond may be held until such suits, actions, claims for injuries or damages have been settled and suitable evidence to that effect furnished to the Owner; except that money due the Contractor will not be withheld when the Contractor produces satisfactory evidence that adequate Workman's Compensation, Public Liability, and Property Damage Insurance are in effect.

The indemnification obligations of the Contractor shall not extend to the liability of the Owner, Engineer, and their affiliates arising out of the preparation or approval of the Plans,

Specifications, maps, opinions, reports, surveys, or Change Orders, or for providing directions or instructions which are the primary cause of the injury or damage.

Should the Owner or Contractor suffer from any injury or damage due to an error, omission, or act of the other party or their legally liable affiliates, a written Claim shall be submitted to the other party within ten (10) days. The Claim shall provide all details regarding the injury or damage, the results of any investigations, and the action to be taken to prevent any reoccurrence.

#### GP-52 LIABILITY FOR LOSSES BY ACTS OF THE GOVERNMENT

The Owner shall not be liable for any loss or damage suffered by the Contractor arising out of a cessation of Work under this Contract due to any act or order of any local, state, or federal government agency. If this cessation occurs, the Contractor may request an extension of the Contract Time according to the provisions in GP-44.

#### GP-53 SUBSTANTIAL COMPLETION

Upon notice from the Contractor that it believes the project has reached substantial completion, and before final acceptance, the Engineer will make an inspection of the Work. "Substantial Completion" is defined as the date on which the Work is complete in accordance with the Contract Documents in order that the Owner can occupy and use the project for its intended use. The date of Substantial Completion shall be specified in the Notice of Acceptance.

If the Owner or its representative determines the Project is substantially complete, the Owner will issue a Notice of Acceptance identifying the date the Project reached Substantial Completion and attach a punch list, if applicable, identifying the remaining items that must be completed before final payment. The Contractor shall then file the executed Notice of Acceptance with the Clerk of Court in the Parish(s) where the work is performed and shall forward one complete copy of the recorded acceptance to the Owner and Engineer.

If the inspection discloses any work as being unsatisfactory or incomplete and such work generates a formal punch list, the Engineer will give the Contractor instructions for correction of same, and the Contractor shall immediately comply with such instructions. Upon satisfactory completion of the corrections, when a "Punch List" is generated, the Engineer shall prepare a "Recommendation of Acceptance" incorporating the punch list and submit to the Owner. Upon approval of the Recommendation of Acceptance, the Owner may issue a Notice of Acceptance of the Contract which shall establish the date of Substantial Completion.

Any punch list generated by the Engineer shall be accompanied by a cost estimate to correct the particular items of work the Engineer has developed. The cost estimate shall be developed based on mobilization, labor, material, and equipment costs of correcting each punch list item and shall be retained from monies owed to the Contractor, above and beyond the standard retainage. The Engineer shall retain his working papers used to determine the punch list items cost estimates should the matter be disputed later. The Owner shall not withhold from payment more than the value of the punch list. Punch list items completed shall be paid upon the expiration of the forty-five (45) day lien period. After that payment, none of the remaining funds shall be due the Contractor until all punch list items are completed and are accepted by the Engineer.

If the dollar value of the punch list exceeds the amount of funds, less retainage amount, in the remaining balance of the Contract, the Project shall not be accepted as Substantially Complete. If the funds remaining are less than required to complete the punch list work, the Contractor shall pay the difference. The provisions listed above shall not be subject to waiver.

Warranties required by the Contract Documents shall commence on the date of Substantial Completion of the Work/project as provided in the Notice of Acceptance, unless otherwise agreed to in writing by the Owner and Contractor. In the instance where the Owner has accepted the Work/project as substantially complete and issued a Notice of Acceptance, and the Contractor must remain on the premises to complete the "Punch List" or for whatever reason, the Contractor shall maintain Commercial General Liability insurance, Auto Liability insurance and Worker's Compensation insurance as set forth herein until the expiration of the forty-five (45) day lien period or upon the completion of the work/project, whichever is later. Builder's Risk insurance, if applicable, may be cancelled only with the written permission of the Owner or the Owner's representative at Substantial Completion.

If the punch list is not completed within forty-five (45) days, through no fault of Owner or Engineer, the Owner may, but is not required, to place the Contractor in default. Thereafter, the Owner shall notify the Surety. If the Surety has not completed the punch list within forty-five days of receipt of notification, the Owner may, but is not required to, complete the remaining punch list items. Any costs incurred shall be paid for first out of any remaining Contract funds. If the costs incurred exceed the remaining Contract funds, the Contractor and its Surety shall be liable for such costs.

Upon completion of the punch list, Contractor shall request Final Inspection.

#### GP-54 FINAL INSPECTION AND ACCEPTANCE

Whenever the work provided for, or contemplated by the contract, have been satisfactorily completed, all punch list items completed and the final cleaning up is performed, the Engineer shall be notified in writing that said work is completed and ready for final inspection. The Engineer shall, unless otherwise provided, make the final inspection within a reasonable length of time after the receipt of such notification.

If all construction provided for in the contract is found completed to the Engineer's satisfaction, that inspection shall constitute the final inspection and the Engineer will make recommendation to the Owner for final acceptance and notify the Contractor in writing of this recommendation of acceptance.

#### GP-55 AS-BUILT DRAWINGS

The Contractor shall submit all originals and copies of the As-Built Drawings to the Engineer for review and acceptance in accordance with the Special Provisions. The As-Built Drawings shall provide complete data for quantities, dimensions, specified performance and design criteria, and similar items which clearly represent the services, materials, and equipment the Contractor has provided. All revision sheets shall be clearly stamped with the words "As-Built".

## GP-56 COMPLETION OF CONTRACT

Notwithstanding any other provision of this Contract and all applicable and necessary time delays under Louisiana law, completion of the Contract requires all of the Work to be complete, inspected by the Engineer, accepted by the Owner as recommended by the Engineer, and after final payment is made. After the Contract is complete, the Contractor will then be released from further obligation except as set forth in the Contract Bond and Contractor's Guarantee.

## GP-57 CONTRACTOR'S GUARANTEE

The Contractor is obligated to provide a written guarantee to the Owner that all of the Work conforms to the Contract Documents. The Work shall be guaranteed to survive for a minimum period of 1 year after final acceptance, unless otherwise specified in the Technical Specifications.

- a. The guarantee shall include:
  1. A written warranty by the manufacturer for each piece of installed project equipment or apparatus furnished under the Contract.
  2. Any necessary repair or replacement of the warranted equipment during the guarantee period at no cost to the Owner.
  3. Satisfactory operation of installed equipment including, but not limited to, any mechanical and electrical systems furnished and constructed under the Contract during the guarantee period. The Contractor shall repair all equipment which fails due to defective materials or faulty workmanship during the guarantee period. The Contractor shall also be liable for all other ancillary expenses incurred by the Owner due to the failure.
- b. The guarantee shall exclude defects or damage caused by:
  1. Abuse or improper modification, maintenance, or operation by anyone other than the Contractor; or
  2. Wear and tear under normal usage.
- c. This obligation by the Contractor shall be absolute. The following actions will not constitute acceptance of non-conformance Work or release the Contractor from obligation to furnish the Work in accordance with the Contract Documents:
  1. Observations by the Owner or Engineer; or
  2. Recommendations by the Engineer or payment by the Owner; or
  3. Use of the Work by the Owner; or
  4. Issuance of a notice of acceptance by the Owner pursuant to the provisions of GP-53, or failure to do so; or



5. Any inspection, test, or approval by others; or
6. Any correction to non-conforming work by the Owner.

#### GP-58 DISPUTE RESOLUTION

The parties shall use their best efforts to resolve all disputes in an amicable fashion. Prior to filing suit by either party with respect to any claims, or disputes arising between the parties, the disputes shall be submitted first to non-binding mediation. The mediation shall be conducted in accordance with the Construction Industry Mediation Rules of the American Arbitration Association. If the parties cannot agree to a private mediator, then the mediator shall be selected by the American Arbitration Association, upon the filing of a demand for mediation.

If the dispute is not resolved by mediation within 60 days from the request for mediation, then either party may institute legal proceedings. Any litigation involving the Owner and arising under or related to the Contract or the bidding or award thereof shall be instituted exclusively in the 19<sup>th</sup> Judicial District Court in and for the Parish of East Baton Rouge, State of Louisiana.

#### GP-59 PAYMENT

The Owner hereby agrees to pay to the Contractor as full compensation for all work performed under the contract, and/or supplemental agreements thereto, the monetary value of the actual quantities in the completed work according to the schedule of unit prices and/or lump sum prices set forth in attached bid proposal and/or duly authorized supplements thereto, and made a part of the Contract.

Partial payments under the Contract shall be made at the request of the Contractor not more than once each month, based upon partial estimates agreed to by the Contractor and Engineer and shall be furnished to the Engineer and approved by the Engineer prior to transmittal to the Owner for approval and payment.

The partial estimates will be approximately stated, and all partial estimates and payments shall be subject to corrections in the estimate rendered following the discovery of any error in any previous estimates.

The payment of the partial estimate shall be taken as verification that the work has been performed and that its quality is satisfactory, however it will in no way serve as a release to the Contractor for the responsibility of any portions thereof. The work and any particulars relating thereto shall be subject to revision and adjustment by the Engineer and/or the Owner at any time prior to final payment, regardless of any previous action taken.

There shall be reserved from the payments provided for the Contract ten percent (10%) for contracts less than \$500,000 or five percent (5%) for contracts of \$500,000 or more, of the estimates submitted, said sum to constitute a trust fund for the protection of and payment to any person or persons, mechanic, subcontractor or materialmen who shall perform any labor upon such contract, or the doing of said work, and all persons who shall supply such person or persons or subcontractors with provisions and supplies for the carrying on of such work,

and shall be withheld for a minimum of forty-five (45) calendar days after final acceptance of the completed contract.

After the expiration of the forty-five (45) calendar day period, the reserve in excess of a sum sufficient to discharge the claims of materialmen and laborers who have filed their claims, together with a sum sufficient to defray the cost of such action and to pay attorneys' fees, shall be paid to the Contractor.

The Contractor shall be responsible for obtaining and furnishing a clear lien and privilege certificate to the Owner at the expiration of the retainage period, and prior to payment of any reserve withheld.

#### GP-60 PAYMENTS WITHHELD

In addition to the percentage provided for in Section GP-58 of these General Provisions and in accordance with any other provision of this Contract, the Owner may withhold such amounts from any payment as may be necessary to protect himself from loss on account of:

- a) Defective work not remedied;
- b) Claims filed or reasonable evidence indicating probable filing of claims;
- c) Failure of the Contractor to make payments properly to subcontractors or for material or labor;
- d) Reasonable evidence that the Work will not be completed within the Contract time and that the unpaid balance would not be adequate to cover damages for the anticipated delay;
- e) A reasonable doubt that the contract can be completed within the time period remaining under the contract;
- f) Damage to another contractor;
- g) Failure to submit required reports; or
- h) Modifications of the contract which necessitate the execution of change orders prior to payment of funds.

Furthermore, nothing contained in this Section shall be deemed to limit the right of the Owner to withhold liquidated damages, as stated in the Instructions to Bidders and as permitted under Section SP-7 of the Special Provisions, from any amounts which may be due and owing the Contractor for work performed under the contract.

#### GP-61 LIENS

Neither the final payment nor any part of the retained percentage shall come due until the Contractor shall deliver to the Owner a complete release of all liens arising out of this contract, or receipts in full in lieu thereof, and, if required by the Owner, an affidavit that so far as he has knowledge or information, the releases and receipts include all labor and material for which a lien could be filed; but if any subcontractor refuses to furnish a release or receipt in full, the Contractor may furnish a bond satisfactory to the Owner to indemnify the Owner against any lien, construction cost, or attorney's fees.

#### GP-62 EQUAL EMPLOYMENT OPPORTUNITY

The State of Louisiana is an equal opportunity employer, and looks to its Contractor, subcontractors, vendors and suppliers to take affirmative action to effect this commitment in its operations.

By submitting the bid proposal and executing the Contract, the Contractor agrees to abide by the requirements of the following as applicable: Title VI and VII of the Civil Rights Act of 1964, as amended by the Equal Opportunity Act of 1972, Federal Executive Order 11246, the Federal Rehabilitation Act of 1973, as amended, the Vietnam Era Veterans Readjustment Assistance Act of 1974, Title IX of the Education Amendments of 1972, and the Age Act of 1975, and the Contractor agrees to abide by the requirements of the Americans with Disabilities Act of 1990.

The Contractor agrees not to discriminate in its employment practices, and will render services the Contract, without regard to their race, age, color, religion, sex, national origin, veteran status, political affiliation or disabilities. Any act of discrimination committed by the Contractor, or failure to comply with these statutory obligations when applicable, shall be grounds for termination of the Contract.

#### GP-63 ANTI-KICKBACK CLAUSE

The Contractor agrees to adhere to the mandate dictated by the Copeland "Anti-Kickback" Act which provides that each contractor or subcontractor shall be prohibited from inducing, by any means, any person employed in the completion of the work, to give up any part of the compensation to which he is otherwise entitled.

#### GP-64 SUSPENSION/DEBARMENT

Contractor certifies, by signing and submitting any bid, that their company, any subcontractors, or principals are not suspended or debarred by the General Services Administration (GSA) in accordance with the requirements in OMB Circular A-133. A list of parties who have been suspended or debarred can be viewed via the internet at [www.epls.gov](http://www.epls.gov).

Contractor agrees to secure from any contractor(s) and subcontractor(s) for the captioned project, certification that such contractor(s) and subcontractor(s) are not suspended, debarred or declared ineligible from entering into contracts with any department or agency of the Federal Government or of the State of Louisiana, or in receipt of a notice of proposed debarment or suspension.

Contractor shall provide immediate notice to Owner in the event of it or its contractor(s) or any subcontractor(s) being suspended, debarred or declared ineligible by any department or agency of the Federal Government or of the State of Louisiana, or upon receipt of a notice of a proposed debarment or suspension, either prior to or after execution of this Contract.

Upon receipt of notice of suspension, debarment, or declaration that Contractor or its contractor(s) or any subcontractor(s) is/are ineligible to enter into contracts with any department or agency of the Federal Government or of the State of Louisiana, either prior to or after execution of this Contract, Owner reserves the right to review cause for said debarment, suspension, or declaration of ineligibility, and to terminate this Contract pursuant to the terms of GP-45 OWNER'S RIGHT TO TERMINATE CONTRACT FOR CAUSE OR CONVENIENCE, or take such other action it deems appropriate under this Contract.

#### **GP-65 LOUISIANA FIRST HIRING ACT**

Contractor shall comply with the Louisiana First Hiring Act (La. R.S. 39:2201-2204), which requires that within ten (10) days of executing the Contract, Contractor shall submit the following information to the Louisiana Workforce Commission:

1. The number and types of jobs anticipated for the Work.
2. The skill level of the jobs anticipated for the Work.
3. The wage or salary range for each job anticipated for the Work.
4. Methods, if any, that the Contractor will use to recruit unemployed persons or person employed in low wage jobs to fill job openings for the Work.

#### **END OF PART I - GENERAL PROVISIONS**

**END OF PART I - GENERAL PROVISIONS**

## **PART II SPECIAL PROVISIONS**

### **SP-1 LOCATION OF WORK**

The Project Site is located in Cameron Parish, Louisiana. It surrounds the community of Grand Lake and extends from the northeastern shore of Calcasieu lake in a southeasterly direction to the GIWW and generally parallels LA Hwy 384.

### **SP-2 WORK TO BE DONE**

- 2.1 Scope: The Contractor shall provide all labor, materials, and equipment necessary to perform the Work. The Work shall include, but not be limited to, mobilization and demobilization at the Project Site. The Work shall be performed in accordance with these Specifications and in conformity to lines, grades, and elevations shown on the Plans or as directed by the Engineer. Quantity calculations, layouts, shop drawings, and construction sequencing of these items shall be provided in the Work Plan. The major tasks associated with the Work are described as follows:
  - 2.1.1 Dredge the inlet Channel (approximately 1128') between the GIWW and Structure No.1. Original Channel Design: 18' bottom width, 2:1 side slopes, bottom elevation -2.11 ft NAVD 88. The spoil material is to be side cast.
  - 2.1.2 Structure No. 1 Maintenance: Remove the debris and sediment around the hyacinth fence, flush the three culverts to clear any sediment, and remove debris or rocks from the outlet side flapgates.
  - 2.1.3 Replace any missing wire on the hyacinth fence located at Structure No.1.
  - 2.1.4 Replace or repair any loose or deteriorating boards on the walkway to the Continuous Monitoring Station, 29r, located adjacent to the hyacinth fence at Structure No. 1.
  - 2.1.5 Repair the Levee/Road located North of Structure No.1 to the original design elevation to prevent further overtopping during high tide events. Original Road Design Elevation: +3.5' NAVD 88.
- 2.2 Use of Equipment - The equipment used for the Work shall be operated within the boundaries of the Project Site and away from sensitive areas. The Contractor shall be responsible for returning all disturbed wetlands to pre-existing conditions at no expense to the Owner.
- 2.3 Navigation Depths - Areas containing navigable depths shall not be impaired except as allowed by applicable laws or regulations. It is the responsibility of the Contractor to select equipment that can navigate from a maintained navigation channel to the Project Site without dredging. All equipment shall remain floating at all times during the transit to the Project Site. The Contractor shall obtain NOAA Nautical Charts and/or other charts to become familiar with the depths in the vicinity of the Project Site.

SP-3 BID ITEMS, CONTRACT DATES, AND DELIVERABLES

| Milestone                                      | Location or Recipient              | Date Due   |
|--|------------------------------------|--|
| Advertisement for Bids                         | Publications                       | As advertised  |
| Mandatory Pre-Bid Conference and Jobsite Visit | Provided in Advertisement for Bids | Provided in Advertisement for Bids   |
| Questions on Bid Documents                     | Deliver to CPRA                    | As Announced at the Pre-Bid Conference   |
| Effective Date of Contract                     | Contractor and Owner               | Stated in Contract between Owner and Contractor                                  |
| Start of Contract Time                         | Contractor and Owner               | As stated in Notice to Proceed   |
| Work Plan                                      | Submit to Engineer                 | At least 14 days prior to Pre-Construction Conference                            |
| Progress Schedule                              | Submit to Engineer                 | At least 14 days prior to starting construction, monthly thereafter              |
| Pre-Construction Conference                    | Contractor and Engineer            | As determined by the Engineer after the Notice to Proceed is issued              |
| Progress Meetings and Reports                  | At Project Site                    | Bi-weekly or as determined at the Pre-Construction Conference (See GP-13, GP-39) |
| As-Built Drawings                              | Deliver to Engineer                | Prior to Final Inspection as scheduled by the Engineer                           |
| End of Contract Time                           | At Project Site                    | <b>30</b> calendar days after Notice to Proceed for Base Bid                     |

SP-4 DELIVERABLES

4.1 Prior to Construction

4.1.1 The Contractor shall submit the following documents to the Engineer prior to the Pre-Construction Conference specified in GP-14:

4.1.1.1 Work Plan as specified in GP-8 and SP-6;

4.1.1.2 Progress Schedule as specified in GP-9;

4.1.1.3 Copy of typical Daily Progress Report as specified in GP-10.

4.1.1.4 Hurricane and Severe Storm Plan as specified in GP-11;

4.1.1.5 Health and Safety Plan as specified in GP-12.

4.1.2 The Contractor shall provide the following information to the Engineer at the Pre-Construction Conference specified in GP-14:

4.1.2.1 Updates to all plans and schedules based on comments from the Engineer;

4.1.2.2 Potential construction corridors (if needed, other than from what is provided) which may be approved on an as needed basis.

#### 4.2 During Construction

The Contractor shall deliver copies of the following documents upon request by the Engineer, or as specified in these provisions:

- 4.2.1 The results of all surveys and calculations;
- 4.2.2 Progress Schedule as specified in GP-9;
- 4.2.3 Daily Progress Reports as specified in GP-10;
- 4.2.4 Copies of all inspection reports;
- 4.2.5 All Change Orders, Field Orders, Claims, Clarifications, and Amendments;
- 4.2.6 Results of any materials testing.

#### 4.3 Administrative Records

##### 4.3.1 Notice of Intent to Dredge

At least 30 days prior to commencement of Work on this Contract, the Contractor shall notify the U.S. Coast Guard, Sector New Orleans Command Center, at the address below, of his intended operations to dredge and request that it be published in the Local Notice to Mariners. This notification must be given in sufficient time so that it appears in the Notice to Mariners at least seven (7) days prior to the commencement of this dredging operation. A copy of the Department of the Army Permit and drawings shall be provided to the U.S. Coast Guard. A copy of the notification shall be provided to the Owner and Engineer.

U.S. Coast Guard  
Sector New Orleans Command Center  
201 Hammond Hwy  
Metairie, LA 70005  
504-846-5923

##### 4.3.2 Relocation of Navigational Aids

Temporary removal of any navigation aids located within or near the areas required to be dredged or filled and material stockpile areas shall be coordinated by Contractor with the U.S. Coast Guard prior to removal. The Contractor shall not otherwise remove, change the location of, obstruct, willfully damage, make fast to, or interfere with any aid to navigation. The Contractor shall notify the Eighth U.S. Coast Guard District, New Orleans, Louisiana, in writing, with a copy to the Owner and Engineer, seven (7) days in advance of the time he plans to dredge or Work adjacent to any aids which require relocation to facilitate the Work. The



Contractor shall contact the U.S. Coast Guard for information concerning the position to which the aids will be relocated.

#### 4.3.3 Dredging Aids

The Contractor shall obtain approval for all dredging aids, including but not limited to temporary navigation aids, warning signs, buoys, and lights, he requires to conduct the Work specified in this Contract. The Contractor shall obtain a temporary permit from the U.S. Coast Guard for all buoys or dredging aid markers to be placed in the water prior to installation. The permit application shall state the position, color, and dates to be installed and removed for all dredging aid markers and be submitted to the U.S. Coast Guard. Dredging aid markers and lights shall not be colored or placed in a manner that they will obstruct or be confused with navigation aids. Copies of the application and permit shall be submitted to the Owner and Engineer seven (7) days prior to commencement of dredging operations.

#### 4.3.4 Notification of Discovery of Historical or Cultural Sites

If during construction activities the Contractor observes items that may have pre-historic, historical, archeological, or cultural value, the Contractor shall immediately cease all activities that may result in the destruction of these resources and shall prevent his employees from trespassing on, removing, or otherwise damaging such resources. Such observations shall be reported immediately to the Owner and Engineer so that the appropriate authorities may be notified and a determination made as to their significance and what, if any, special dispositions of the finds should be made. The Contractor shall report any observed unauthorized removal or destruction of such resources by any person to the Owner and Engineer so the appropriate State of Louisiana authorities can be notified. The Contractor shall not resume Work at the site in question until State authorities have rendered judgment concerning the artifacts of interest.

### 4.4 Post Construction

The Contractor shall contact the Engineer by phone, a minimum of five (5) working days prior to the anticipated completion of the Work in order to schedule the final inspection and gain Acceptance by the Engineer. The following documents shall also be submitted to the Engineer:

- 4.4.1 Copies of all delivery slips, which shall include the source of construction materials, date of delivery, exact quantity, and size of materials delivered with each shipment to the Project Site;
- 4.4.2 As-Built Drawings as specified in TS-6.

4.5 Summary of Project Submittals

The following table is a summary of submittals required of the Contractor as part of this section and other sections of these Specifications:

| SPECIFICATION | DELIVERABLE                          | SUBMITTAL                            |
|---------------|--------------------------------------|--------------------------------------|
| GP-9          | Progress/Work Schedule               | Prior to Pre-construction conference |
| GP-19         | Names of all Subcontractors          | Prior to awarding subcontracts       |
| GP-10         | Daily Progress Reports               | As directed by the Engineer          |
| GP-54         | Written Notice of Completion of Work | Upon completion of work              |

SP-5 CONTACT INFORMATION

Prior to Bid opening date, the Contractor shall send all questions and requests for clarification or interpretation of Bid Documents to the attention of Renee McKee of Coastal Protection and Restoration Authority. The address and contact information is as follows:

Coastal Protection and Restoration Officer  
 Coastal Protection and Restoration Authority  
 450 Laurel Street, Suite 1501  
 Baton Rouge, LA 70801  
 Phone: 225-342-0811  
 Fax: 225-342-4674  
 Email : [cpra.bidding@la.gov](mailto:cpra.bidding@la.gov)

After execution of the Contract between the Owner and Contractor, the successful Contractor shall contact the Engineers concerning bid documentation or questions. The addresses and contact information for the Engineers are listed as follows:

Project Engineer  
 Beau Tate, P.E.  
 Royal Engineers and Consultants, LLC  
 1231 Camellia Boulevard  
 Lafayette, LA 70508  
  
 Phone: 337-456-5351  
 Fax: 337-456-5356  
 Email: [btate@royalengineering.net](mailto:btate@royalengineering.net)

Field Engineer  
 Jody Roger-White, P.E.  
 CPRA - Lafayette Field Office  
 635 Cajundome Blvd.  
 Lafayette, LA 70506  
  
 Phone: 337-482-0664  
 Fax: 337-482-0685  
 Email: [jody.white@la.gov](mailto:jody.white@la.gov)

The Owner and Engineer shall deliver all written Claims, Notices, Submittals, Plans, and other documents to the Contractor at the address indicated on the Bid.

#### SP-6 WORK PLAN SUPPLEMENTAL

The following items shall be included in the Work Plan in addition to those required by GP-8:

- 6.1 Layout and construction schedule for dredging of Inlet Channel;
- 6.2 Layout and construction schedule for Levee/Road Repair;
- 6.3 Layout and construction schedule for Structure Maintenance;

#### SP-7 FAILURE TO COMPLETE ON TIME

For each day the Work remains incomplete beyond the Contract Time, as specified in SP-3, or Extension of Contract Time, as specified in GP-44, the sum of five hundred dollars (\$500) per calendar day will be deducted from any money due to the Contractor as liquidated damages. The Contractor and Surety shall be liable for any liquidated damages that are in excess of the amount due the Contractor.

#### SP-8 TRANSPORTATION

The Contractor shall provide a safe and reasonable means of transportation to and from the marine access structure, staging area, and Project Site for the Engineer and the federal sponsor throughout the Work. The schedule and pickup location shall be arranged by the Engineer and the Contractor prior to mobilization. Upon request, overnight room and board shall be provided to these personnel by the Contractor if adequate facilities are available. The Contractor shall provide a boat for the exclusive use of the Engineer and/or Resident Project Representative to tour the Project Site during the Work. The boat shall have the following features:

- 8.1 An enclosed cabin space;
- 8.2 Capable of maintaining 25 knots (29 mph);
- 8.3 Six (6) passenger capacity;
- 8.4 Coast Guard certified;
- 8.5 Operable marine radio;
- 8.6 All safety equipment required by the Coast Guard for the size and type of that boat;
- 8.7 Draft of two feet (2') or less.

The Contractor shall supply the fuel and maintain the boat. All mechanical malfunctions of the boat shall be repaired within twelve (12) hours. In the event that the Contractor refuses, neglects, or delays compliance with the requirements of this provision, the Owner may obtain and use other necessary boats at the expense of the Contractor. The costs associated with providing the boats shall be included in the lump sum price for Bid Item No. 1, "Mobilization and Demobilization".

#### SP-9 RESERVED

#### SP-10 OFFICE FOR OWNER

The Contractor shall provide an office for the Engineer and Resident Project Representative at the Project Site if requested by the Engineer. This office shall be for the sole use of the Engineer or Resident Project Representative, suitably sized, and provided with lighting, heat, and air conditioning. The office furnishings shall include a work table, drafting table, stool, and two chairs.

In the event that the Contractor refuses, neglects, or delays compliance with the requirements of this provision, the Owner may obtain and use another necessary office at the expense of the Contractor. The cost for providing and furnishing this office shall be included in the contract lump sum price for Bid Item No. 1, "Mobilization and Demobilization".

#### SP-11 LANDOWNER AND PIPELINE REQUIREMENTS

The Owner has obtained all temporary easement, servitude, and right-of-way agreements required for construction of the project. The agreements executed with landowners for the Work at the site contain special requirements pertaining to access routes and insurance. A land rights memorandum is included in Appendix C. The Contractor shall abide by the stipulations set forth by the respective landowners (Grantors), which can be found in Appendix B.

The Contractor shall add the landowners listed in Appendix H as additional insured. It is also agreed and understood that the Contractor will at all times indemnify and hold harmless all landowners from and against any and all claims, demands, causes of action, judgments, liabilities, and expense of every nature, including attorney's fees, by reason of personal injury, death (including but not limited to injuries to and death of employees of the landowners and the Contractor's employees) or damage to property, (including environmental) which arises out of, results from, or is in any manner related to, directly or indirectly, any operations or acts hereunder, or to the exercise of your rights hereunder, or to your presence upon or use of the landowners' premises above referred to, or to the use or existence of your facilities on such premises. The indemnity provisions of this paragraph shall not apply if any such injury, death, damage, liability claim, or cause of action is caused by the negligence of the landowners, their employees, agents, or representatives.

The Contractor shall notify all pipeline companies at least seventy-two (72) hours in advance of any construction work. All pipelines located within one hundred fifty feet (150') of the containment dike alignments, marsh fill areas, and borrow areas shall be probed and their locations marked prior to excavation. No excavation shall be permitted within fifty feet (50') of any pipeline.

#### SP-12 OYSTER LEASE RESTRICTIONS

There are no known existing oyster leases near or within the boundaries of the Project Site. Therefore, no oyster lease restrictions are provided for performing the Work within the boundaries of the Project Site.

SP-13 INSURANCE AND BONDS

13.1 INSURANCE REQUIREMENTS FOR NEW CONSTRUCTION, ADDITIONS, AND RENOVATIONS

The Contractor shall purchase and maintain without interruption for the duration of the contract insurance against claims for injuries to persons or damages to property which may arise from or in connection with the performance of the Work hereunder by the Contractor, its agents, representatives, employees or subcontractors. The duration of the contract shall be from the inception of the contract until the date of final payment.

13.2 MINIMUM SCOPE AND LIMITS OF INSURANCE

13.2.1 WORKER’S COMPENSATION

Worker’s Compensation insurance shall be in compliance with the Worker’s Compensation law of the State of Louisiana. Employers Liability is included with a minimum limit of \$500,000 per accident/per disease/per employee. If Work is to be performed over water and involves maritime exposure, applicable LHWCA, Jones Act or other maritime law coverage shall be included and the Employers Liability limit increased to a minimum of \$1,000,000. A.M. Best’s insurance company rating requirement may be waived for Worker’s compensation coverage only.

13.2.2 COMMERCIAL GENERAL LIABILITY

Commercial General Liability insurance, including Personal and Advertising Injury Liability and Products and Completed Operations Liability, shall have a minimum limit per occurrence based on the project value. The Insurance Services Office (ISO) Commercial General Liability occurrence coverage form CG 00 01 (current form approved for use in Louisiana), or equivalent, is to be used in the policy. Claims-made form is unacceptable.

The aggregate loss limit must apply to each project. ISO form CG 25 03 (current form approved for use in Louisiana), or equivalent, shall also be submitted. The State project number, including part number, and project name shall be included on this endorsement.

**COMBINED SINGLE LIMIT (CSL) PER OCCURRENCE**

The required minimum combined single limit amount of insurance shall be as provided below:

| <b><u>Initial Contract Amount</u></b>  | <b><u>Minimum Insurance</u></b> |
|--|---------------------------------|
| <b>Up to \$1,000,000</b>               | <b>\$1,000,000</b>              |
| <b>From \$1,000,001 to \$2,000,000</b> | <b>\$2,000,000</b>              |
| <b>Over \$2,000,000</b>                | <b>\$5,000,000</b>              |

### 13.2.3 AUTOMOBILE AND WATERCRAFT LIABILITY

Automobile Liability Insurance and Watercraft Liability Insurance shall have a minimum combined single limit per occurrence of \$1,000,000. ISO form number CA 00 01 (current form approved for use in Louisiana), or equivalent, is to be used in the policy. This insurance shall include third-party bodily injury and property damage liability for owned, hired and non-owned automobiles and/or watercraft. If any non-licensed motor vehicles and/or watercraft are engaged in operations within the terms of the contract on the site of the work to be performed thereunder, such insurance shall cover the use of any such vehicles.

NOTE: If the Contractor does not own automobiles and/or watercraft, and such vehicles are utilized in the execution of the contract, then hired and non-owned coverage is acceptable. If automobiles and/or watercraft are not utilized in the execution of the contract, then automobile and/or watercraft coverage is not required.

### 13.2.4 EXCESS UMBRELLA

Excess Umbrella Insurance may be used to meet the minimum requirements for General Liability, Automobile Liability, and Watercraft Liability only.

### 13.2.5 POLLUTION LIABILITY *(required when asbestos or other hazardous material abatement is included in the contract)*

Pollution Liability insurance, including gradual release as well as sudden and accidental, shall have a minimum limit of not less than \$1,000,000 per claim. A claims-made form will be acceptable. A policy period inception date of no later than the first day of anticipated Work under this contract and an expiration date of no earlier than 30 days after anticipated completion of all Work under the contract shall be provided. There shall be an extended reporting period of at least 24 months, with full reinstatement of limits, from the expiration date of the policy. The policy shall not be cancelled for any reason, except non-payment of premium.

### 13.2.6 DEDUCTIBLES AND SELF-INSURED RETENTIONS

Any deductibles or self-insured retentions must be declared to and accepted by the Owner. The Contractor shall be responsible for all deductibles and self-insured retentions.

## 13.3 OTHER INSURANCE PROVISIONS

The policies are to contain, or be endorsed to contain, the following provisions:

### 13.3.1 WORKER'S COMPENSATION AND EMPLOYERS LIABILITY COVERAGE

The insurer shall agree to waive all rights of subrogation against the Owner, its officers, agents, employees and volunteers for losses arising from Work performed by the Contractor for the Owner.

### 13.3.2 GENERAL LIABILITY COVERAGE

- 13.3.2.1 The Owner, its officers, agents, employees and volunteers are to be added as additional insureds as respects liability arising out of activities performed by or on behalf of the Contractor; products and completed operations of the Contractor, premises owned, occupied or used by the Contractor. ISO Form CG 20 10 (current form approved for use in Louisiana), or equivalent, is to be used.
- 13.3.2.2 The Contractor's insurance shall be primary as respects the Owner, its officers, agents, employees and volunteers. The coverage shall contain no special limitations on the scope of protection afforded to the Owner, its officers, officials, employees or volunteers. Any insurance or self-insurance maintained by the Owner shall be excess and non-contributory of the Contractor's insurance.
- 13.3.2.3 The Contractor's insurance shall apply separately to each insured against whom claim is made or suit is brought, except with respect to the policy limits.

### 13.3.3 ALL COVERAGES

- 13.3.3.1 Coverage shall not be canceled, suspended, or voided by either party (the Contractor or the insurer) or reduced in coverage or in limits except after 30 days written notice has been given to the Owner. Ten-day written notice of cancellation is acceptable for non-payment of premium. Notifications shall comply with the standard cancellation provisions in the Contractor's policy.
- 13.3.3.2 Neither the acceptance of the completed Work nor the payment thereof shall release the Contractor from the obligations of the insurance requirements or indemnification agreement.
- 13.3.3.3 The insurance companies issuing the policies shall have no recourse against the Owner for payment of premiums or for assessments under any form of the policies.
- 13.3.3.4 Any failure of the Contractor to comply with reporting provisions of the policy shall not affect coverage provided to the Owner, its officers, agents, employees and volunteers.

### 13.3.4 ACCEPTABILITY OF INSURERS

All required insurance shall be provided by a company or companies lawfully authorized to do business in the jurisdiction in which the Project is located. Insurance shall be placed with insurers with an A.M. Best's rating of **A-:VI or higher**. This rating requirement may be waived for Worker's compensation coverage only.

If at any time an insurer issuing any such policy does not meet the minimum A.M. Best rating, the Contractor shall obtain a policy with an insurer that meets the A.M. Best rating and shall submit another certificate of insurance as required in the contract.

### 13.3.5 VERIFICATION OF COVERAGE

Contractor shall furnish the Owner with Certificates of Insurance reflecting proof of required coverage. The Certificates for each insurance policy are to be signed by a person authorized by that insurer to bind coverage on its behalf. The Certificates are to be received and approved by the Owner before Work commences and upon any contract renewal thereafter. The Certificate Holder must be listed as follows:

**State of Louisiana  
Coastal Protection and Restoration Authority  
450 Laurel Street, Suite 1501  
Baton Rouge, LA 70501  
Attn: Project # TV-21**

In addition to the Certificates, Contractor shall submit the declarations page and the cancellation provision endorsement for each insurance policy. The Owner reserves the right to request complete certified copies of all required insurance policies at any time.

Upon failure of the Contractor to furnish, deliver and maintain such insurance as above provided, this contract, at the election of the Owner, may be suspended, discontinued or terminated. Failure of the Contractor to purchase and/or maintain any required insurance shall not relieve the Contractor from any liability or indemnification under the contract.

If the Contractor does not meet the insurance requirements at policy renewal, at the option of the Owner, payment to the Contractor may be withheld until the requirements have been met, OR the Owner may pay the renewal premium and withhold such payment from any monies due the Contractor, OR the contract may be suspended or terminated for cause.

### 13.3.6 SUBCONTRACTORS

Contractor shall include all subcontractors as insureds under its policies OR shall be responsible for verifying and maintaining the certificates provided by each subcontractor. Subcontractors shall be subject to all of the requirements stated herein. The Owner reserves the right to request copies of subcontractor's certificates at any time.

If Contractor does not verify subcontractors' insurance as described above, Owner has the right to withhold payments to the Contractor until the requirements have been met.

### 13.3.7 WORKER'S COMPENSATION INDEMNITY

In the event Contractor is not required to provide or elects not to provide Worker's compensation coverage, the parties hereby agree the Contractor, its Owners, agents and employees will have no cause of action against, and will not assert a claim against, the State of Louisiana, its departments, agencies, agents and employees as an employer, whether pursuant to the Louisiana Worker's Compensation Act or otherwise, under any circumstance. The parties also hereby agree that the State of Louisiana, its departments, agencies, agents and employees shall in no circumstance be, or considered as, the employer or statutory employer of Contractor, its Owners, agents and employees. The parties further



agree that Contractor is a wholly independent Contractor and is exclusively responsible for its employees, Owners, and agents. Contractor hereby agrees to protect, defend, indemnify and hold the State of Louisiana, its departments, agencies, agents and employees harmless from any such assertion or claim that may arise from the performance of this contract.

#### 13.3.8 INDEMNIFICATION/HOLD HARMLESS AGREEMENT

Contractor agrees to protect, defend, indemnify, save, and hold harmless, the State of Louisiana, all State Departments, Agencies, Boards and Commissions, its officers, agents, servants, employees and volunteers, from and against any and all claims, damages, expenses and liability arising out of injury or death to any person or the damage, loss or destruction of any property which may occur, or in any way grow out of, any act or omission of Contractor, its agents, servants and employees, or any and all costs, expenses and/or attorney fees incurred by Contractor as a result of any claims, demands, suits or causes of action, except those claims, demands, suits or causes of action arising out of the negligence of the State of Louisiana, all State Departments, Agencies, Boards, Commissions, its officers, agents, servants, employees and volunteers.

Contractor agrees to investigate, handle, respond to, provide defense for and defend any such claims, demands, suits or causes of action at its sole expense and agrees to bear all other costs and expenses related thereto, even if the claims, demands, suits, or causes of action are groundless, false or fraudulent.

#### 13.4 PERFORMANCE AND PAYMENT BOND

##### RECORDATION OF CONTRACT AND BOND [RS 38:2241A(2)]

The Contractor shall record within thirty (30) days the Contract between Owner and Contractor, and Performance and Payment Bond with the Clerk of Court in the Parish in which the Work is to be performed. The Contractor shall obtain a Certificate of Recordation from the Clerk of Court and forward this Certificate immediately to the Coastal Protection and Restoration Authority contact person listed in the Advertisement for Bids. No requests for payment will be processed until receipt of the Certificate of Recordation.

**END OF PART II -SPECIAL PROVISIONS**

## **PART III TECHNICAL SPECIFICATIONS**

### TS-1 SCOPE OF WORK

#### 1.1 General Description

The Work to be performed under these Plans and Specifications consists of furnishing all labor, materials, and equipment for performing all Work listed below in accordance with these Specifications and in conformity to lines, grades, and elevations shown on the Plans or as directed by the Engineer. Major tasks associated with this Work include, but may not necessarily be limited to the following:

1. Mobilization and Demobilization
2. Structure Maintenance
3. Levee Repair
4. Dredging of Inlet Channel
5. Post-Construction Survey

#### 1.2 Site Examination

Bidders are required to examine the Work Area and make determinations of the character of the site and conditions that can be expected. Material such as logs, stumps, snags, tires, scrap, debris and other obstructions may be encountered within the specified Work Area. No separate payment for removal and disposal of these obstructions shall be made. No consideration shall be given to any claims for additional payments based on the failure of the Contractor to inspect the sites.

#### 1.3 Existing Features

The Contractor shall be responsible for investigating, locating, and protecting all existing facilities, structures, services, flow lines, and pipelines on, above, or under the surface of the area where Dredging, Fill Placement, and Equipment transport are to be performed. The Owner will not be held responsible for damage to the Contractor's equipment, employees, subcontractors, adjacent property owners, or anyone else connected with the project due to encountering objects above and/or below sea level.

Existing features, where indicated on the Plans, are shown only to the extent such information was made available to or discovered by the Engineer during the preparation of the Plans. There is no guarantee as to the accuracy or completeness of such information, and all responsibility for the accuracy and completeness is expressly disclaimed. If the Contractor fails to discover an existing underground installation and damages the same, he/she shall be responsible for the cost of the repair and/or replacement of the existing underground installation.

#### 1.4 Permits

The Contractor will be furnished with a copy of each permit issued and shall be responsible for compliance with all provisions and conditions. These permits do not relieve the responsibility of the Contractor from obtaining additional permits that may be needed to complete the work.

## TS-2 MOBILIZATION AND DEMOBILIZATION

### 2.1 General Description

Mobilization consists of preparatory Work and operations, including those necessary for movement of personnel, equipment, supplies and incidentals to and within the Work Area; the establishment of offices, buildings, and other facilities necessary for the work on the project; the cost of bonds and any required insurance; and other pre-construction expenses necessary for start of the work.

### 2.2 Arbitrary Mobilization by Contractor

The Owner will pay for mobilization and demobilization only once. Should the Contractor demobilize prior to completing the project, such demobilization and subsequent remobilization shall be at no cost to the Owner.

### 2.3 Ratio of Mobilization and Demobilization Effort

Sixty percent (60%) of the lump sum price will be paid to the Contractor upon completion of mobilization to the Work Area and after commencement of construction activities. The remaining forty percent (40%) will be paid to the Contractor upon completion of demobilization from the Work Area.

### 2.4 Justification of Mobilization Costs

In the event that the Owner considers the amount in this item, sixty percent (60%) and forty percent (40%) which represents mobilization and demobilization respectively does not bear a reasonable relation to the cost of the Work in this Contract, the Owner may require the Contractor to produce cost data to justify this portion of the Bid. Failure to justify such price to the satisfaction of the Owner will result in payment of actual mobilization costs, as determined by the Owner at the completion of mobilization, and actual demobilization costs at the completion of demobilization, and payment of the remainder of this item in the final payment under this Contract. The determination of the Owner is not subject to appeal.

### 2.5 Measurement and Payment

All costs associated with mobilization and demobilization of the entire Contractor's Equipment, personnel, materials, components and those of his/her Subcontractors and such others costs as may be denoted in the Contract Documents shall be paid for at the Contract lump sum price for Bid Item No. 1 "Mobilization/ Demobilization".

## TS-3 STRUCTURE MAINTENANCE

### 3.1 General Description

The Contractor shall furnish all of the materials, labor, and equipment necessary to perform following tasks for Structural Maintenance:

1. Debris Removal of three culverts at Structure 1 to clear any sediment or obstructions inside the culvert, and removing debris or rocks from the inlet side sluice gate area.
2. Replace any missing wire on the hyacinth fence located at Structure 1.
3. Replace or repair any loose or deteriorating boards on the walkway to the Continuous Monitoring Station, 29r, located adjacent to the hyacinth fence at Structure 1.
4. Removing debris or rocks from the outlet side flap gate area.

The Contractor shall remove all debris from (3) 24" x 43' long corrugated aluminum culverts to ensure Structure No. 1 functions properly. The Contractor shall determine the method of debris removal based on site conditions. The Contractor must obtain approval of any debris removal processes before construction begins. Contractor shall replace any culverts and/or gates damaged during Construction at no expense to the Owner. Acceptance of the Work will be determined from inspection by the Engineer after all Construction is complete.

The Contractor will remove any debris and/or sediment around the hyacinth fence preventing Structure No. 1 from functioning properly. The Engineer will determine any and all material around hyacinth fence needing removal. The Contractor will replace any missing or damaged wire on the hyacinth fence located at Structure No. 1. The Engineer will determine any wire needing replacement on the hyacinth fence.

The Contractor shall remove any loose or deteriorating boards on the walkway to the continuous monitoring station 29r, located adjacent to the hyacinth fence at Structure No.1. The Engineer will determine any boards needing replacement.

The Contractor will remove any debris, sediment, or rocks from the outlet side flapgate area preventing Structure No.1 from functioning properly. Work will be complete after inspection and acceptance of the Work by the Engineer.

If the Work performed by the Contractor is determined to be inadequate by the Engineer, the Contractor will continue the Work at no additional cost to the Owner.

### 3.2 Measurement and Payment

Payment will be awarded as a lump sum amount upon satisfactory inspection of the Project area by the Engineer. All costs associated with Structure Maintenance, including the Contractor's Equipment, personnel, materials, components and those of his/her Subcontractors and such others costs as may be denoted in the Contract Documents shall be paid for at the Contract lump sum price for Bid Item No.2 "Structure Maintenance".

## TS-4 LEVEE REPAIR

### 4.1 General Description

The Contractor shall furnish all of the material, labor, and equipment necessary to repair the Levee located North of Structure No. 1 to the specified design elevation to prevent further overtopping during high tide events. The Contractor is responsible for notifying the landowner prior to entering the project site from Old Dump Road. Landowner contact information can be found on Sheet 2 of the Plans. Alternate access routes are to be approved by the Engineer prior to start of construction.

### 4.2 Elevations and Tolerances

Elevations shall be determined from the GEOID 12A model and NAVD 88 vertical datum. The final minimum elevation of the repaired levee system shall not be less than an elevation of +3.5 feet NAVD 88 with a tolerance of 6 inches. In effect, the final elevation of the repaired levee shall not be less than +3.5 NAVD 88 and not more than +4.0 feet NAVD 88. Existing marsh shall not be disturbed during any and all efforts of levee repair.

### 4.3 Fill Material

Fill material to be used for the Levee Repair shall conform to the specifications given in Sections 4.3.1, 4.3.2, and 4.3.3.

#### 4.3.1 Borrow

Borrow is defined as soils required for construction of embankments or other portions of the work in excess of soils obtained from excavation. Borrow shall be obtained from an existing borrow pit with applicable operating permits and shall be used in accordance with Subsection 4.3.2. The Contractor shall make arrangements for obtaining borrow at no direct pay.

The Contractor will not be permitted to begin borrow operations until all permits have been submitted for review and approval.

#### 4.3.2 Material Requirements

Imported fill shall consist of clean, select material free from debris or organic matter and consist of clay (CH or CL) as defined by the USCS and deemed acceptable for levee fill material. The Contractor is required to submit certification of testing of borrow material.

#### 4.3.3 Placement and Compaction

Fill should be placed in 10 to 12 inch loose lifts. The Contractor will be allowed to use land based equipment for grading and compaction of the fill material. Fill material shall be compacted to 90% of its maximum dry density, as determined by Standard Proctor compaction test (ASTM D698). The Contractor shall perform a Sand Cone field density test (ASTM D1556-90) to determine the field density of the compacted soil. The Contractor is required to perform Sand Cone density tests every 200 feet along the centerline of the levee. The Contractor is required to provide compaction test results to the Engineer for review and Acceptance. Each lift shall be compacted to the requirements set forth in this Section.

#### 4.4 Turfing

The work covered in this Section consists of furnishing labor, equipment, and materials to prepare the seed bed, plant seed, and fertilize to complete turfing.

##### 4.4.1 Submittals

**Equipment List:** A list of proposed seeding and mulching equipment, including descriptive data and calibration tests.

**Delivery:** Delivery schedule shall be submitted at least 10 calendar days prior to the date of the first delivery.

**Seed Certification:** For mixture, percent of live seed, minimum percent germination and hard seed, maximum percent weed seed content, date tested, and State certification.

**Fertilizer Certification:** For chemical analysis and composition percent.

##### 4.4.2 Delivery

**Seed Protection:** Protect from drying out and from contamination during delivery, on-site storage, and handling.

**Fertilizer Delivery:** Deliver to the site in original, unopened containers bearing manufacturer's chemical analysis, name, trade name, trademark, and indication of conformance to state and federal laws. Instead of containers, fertilizer may be provided in bulk with certificate indicating the above information.

**Material Storage:** Materials shall be stored in approved areas. Seed and fertilizer shall be stored in cool, dry locations away from contaminants.

##### 4.4.3 Time Limitations

**Seed:** Apply seed within 24 hours after seed bed preparation.

##### 4.4.4 Seed

**Classification:** Provide State-certified seed of the latest season's crop delivered in original sealed packages, bearing producer's guaranteed analysis for percentages of mixtures, purity, germination, weedseed content, and inert material. Seed shall be labeled in conformance with AMS Seed Act and applicable State seed laws. Wet, moldy, or otherwise damaged seed will be rejected. Seed shall be planted at the rate per acre indicated below:

| Planting Window   | Seed Type   | Pure Live Seed Pounds per Acre |
|---|---|--------------------------------|
| 1 March thru<br>31 October  | Hulled  | 10                             |
|   | Unhulled Common or Coastal Bermuda (Cynodon Dactylon) | 30                             |
|   | Paspalum vaginatum (Seaspray)                         | 30                             |
| 1 November thru<br>28 February  | Hulled  | 10                             |
|   | Unhulled  | 20                             |
|   | Common or Coastal Bermuda (Cynodon Dactylon)          |                                |
|   | Gulf Annual Rye (Lolium multiflorum)                  | 20                             |
|   | Paspalum vaginatum (Seaspray)                         | 20                             |
| NOTE: Pure Live Seed = % Purity x (% Germination + % Hard Seed) / 100 |   |                                |

Quality: Seed shall conform to the applicable State seed laws. Weed seed shall not exceed 1 percent weight of the total mixture.

#### 4.4.5 Fertilizer

Fertilizer shall be commercial grade, free flowing and uniform in composition. Fertilizer for fertilizing with seeding shall be 13-13-13 Grade.

#### 4.4.6 Mulch

Mulch shall be free from noxious weeds, mold, and other deleterious materials.

Wood Cellulose Fiber Mulch: Wood Cellulose Fiber Mulch shall not contain growth or germination-inhibiting factors and shall be dyed an appropriate color to facilitate visual metering during application. Composition on air-dry weight basis: 9 to 15 percent moisture, pH range from 4.5 to 6.0.

Paper Fiber Mulch: Paper fiber mulch shall be recycled news print that is shredded for the purpose of mulching seed.

#### 4.4.7 Water

Source of water shall be of suitable quality for irrigation, containing no elements toxic to plant life, and shall be approved.

#### 4.4.8 Execution

General: Turfing shall be applied to all disturbed areas on the perimeter levee. Seeding and fertilizing operations shall be performed only during periods when beneficial results can be obtained. When drought, excessive moisture, other unsatisfactory conditions prevail, the work shall be stopped when directed. When special conditions warrant variance to the turfing operations, proposed times shall be submitted and approved. Seeding and fertilizing shall be accomplished on disturbed areas.

Site Preparation: Areas to be seeded shall be cultivated to a depth of at least 4 inches. The seed beds shall be cultivated sufficiently to reduce the soil to a state of good tilth when the soil particles on the surface are small enough and lay closely enough together to prevent the seed from being covered too deeply or not deeply enough. Large clumps of soil shall be broken apart and the seedbed surface shall be consistently smooth for optimum germination. Large roots, rocks, and other debris shall be re-



moved.

**Application of Fertilizer:** Fertilizer shall be applied at the rate recommended for mixing simultaneously with seed and mulch in the hydraulic application.

**Seeding:** Prior to seeding, the previously prepared seed bed areas compacted or damaged by interim rain, traffic or other cause, shall be reworked to restore the ground condition previously specified. Seeding operations shall not take place when the wind velocity will prevent uniform seed distribution.

**Hydroseeding:** Seed and fertilizer shall be added to water and thoroughly mixed at the rates specified. Wood cellulose fiber or shredded paper fiber mulch shall be added at the rates recommended by the manufacturer after the seed, fertilizer, and water have been thoroughly mixed to produce a homogeneous slurry. Slurry shall be uniformly applied under pressure over the entire area. The hydroseeded area shall not be rolled.

**Mulch:** Wood cellulose or paper fiber mulch for use with hydraulic application of seed and fertilizer shall be applied as part of the hydro-seeding operation.

**Equipment:** The equipment to be used and the methods of seeding shall be subject to inspection and approval.

**Watering:** Start watering areas seeded as required by temperature and wind conditions. Apply water at a rate sufficient to ensure thorough wetting of soil to a depth of 2 inches without run off. During the germination process, seed is to be kept actively growing and not allowed to dry out.

#### 4.4.9 Permanent Perennial Grass Establishment

The turf establishment shall result in satisfying the "Final Stabilization" requirement of the National Pollutant Discharge Elimination System (NPDES) regulations which state that uniform 70 percent density coverage of a warm-season perennial sod-forming (turf) grass shall be established.

**Final Stabilization:** A satisfactory stand of grass from the seeding operation is defined as a minimum of ten warm-season perennial grass plants per square foot. Areas 100 square feet or larger, that are not covered by a satisfactory stand of grass shall be re-planted. A satisfactory stand of grass will not be accepted as "final stabilization" until a uniform 70 percent density coverage of a warm-season perennial grass has been established.

**Final Inspection:** A final inspection will be held by the Contracting Officer to make note of deficiencies in seeding coverage. Areas not properly seeded as "final stabilization" shall be repaired by the Contractor.

#### 4.5 Measurement and Payment

Payment will be awarded as a linear foot amount upon satisfactory review of the Construction Survey by the Engineer. All costs associated with the Levee Repair, including the Contractor's Equipment, personnel, testing, materials, turfing, components and those of his/her Subcontractors and such others costs as may be denoted in the Contract Documents shall be paid for on a linear foot basis as per Bid Item No.3 "Levee Repair".

## TS-5 DREDGING OF INLET CHANNEL

### 5.1 General Description

The work provided herein consists of furnishing all labor, material, equipment, and performance of all operations required for dredging in-situ earthen material as well as relocating the dredged material to areas designated on the Plans.

### 5.2 Materials

Dredge materials shall be taken from areas designated on the Plans and used for side-casting.

### 5.3 Installation

Dredge materials shall be removed from areas designated on the Plans and placed as side-cast material. Side-casting width and depth should be constructed in accordance with the Plans. The Contractor shall not be allowed to dredge or remove any material that may cause damage to existing marsh. The Contractor is allowed to use any equipment necessary, such as a drag line, barge mounted excavator, clamshell bucket to accomplish the work. The Contractor shall not use any land based equipment for this portion of the work. Any equipment used for dredging and side casting material must stay within the confines of the channel as shown on the plans. It is the Contractor's responsibility to examine the site prior to mobilization to determine the appropriate equipment necessary to perform the work.

### 5.4 Acceptance

Dredge material sections will be inspected for completeness, elevation, width, etc. These measurements will be taken by the Contractor under the supervision of the Engineer or Inspector. Final acceptance will be considered a minimum of fourteen (14) days after all dredge material is placed.

### 5.5 Measurement and Payment

Inlet channel maintenance shall be paid on a linear foot basis. Finished sections will be based on before and after survey cross-sections of the channel. The Contractor's post-construction survey shall consist of cross-sections taken 70 feet on center perpendicular to the centerline of the channel in both directions. Payment will be awarded upon satisfactory review of the Post-Construction Survey by the Engineer. All costs associated with the Dredging of the Inlet Channel, including the Contractor's Equipment, personnel, materials, components and those of his/her Subcontractors and such others' costs as may be denoted in the Contract Documents shall be paid for on a linear foot basis as per Bid Item No.4 "Dredging of Inlet Channel".

## TS-6 CONSTRUCTION SURVEY

### 6.1 General Description

The Contractor shall furnish all of the materials, labor and equipment necessary to perform a post construction survey of the baseline, and transects as shown in the Plans. A magnetometer survey shall be performed to verify locations and depths of pipelines and other obstructions. Magnetometer surveys shall be provided to the Engineer prior to excavation and dredging. All surveys shall be performed by personnel who are approved by the Engineer under the direct supervision of a professional land surveyor licensed in the State of Louisiana. Survey data shall reference the North American Datum of 1983 (NAD 83), Louisiana South Zone, U. S. Survey Feet for horizontal control, and the North American Vertical Datum of 1988 (NAVD 88), U. S. Survey Feet for vertical control. Horizontal and vertical control shall be established by using the GEOID 12A Datum.

### 6.2 Temporary Bench Marks (TBM)

Temporary Bench Marks (TBM): TBMs shall be installed as necessary at any other locations necessary to complete all surveys. Horizontal and vertical coordinates shall be determined for all TBMs installed. The Contractor shall maintain the TBMs for the duration of the Work. The TBMs shall be shown on the plan view drawings.

### 6.3 Baseline & Transects

#### 6.3.1 Levee Repair

Elevations along the baseline shall be taken at every 20 feet and at any abrupt changes in elevation. Survey cross sections shall be surveyed perpendicular to the project baseline every 50 ft beginning and ending at the terminal points shown in the plans. Each cross section shall extend 20' in both directions perpendicular to the baseline. The cross sections shall include all points of inflection and any abrupt changes in elevation along the cross section of the levee.

#### 6.3.2 Channel Cleanout

Elevations along the baseline shall be taken at every 20 feet and at any abrupt changes in elevation. Survey cross sections shall be surveyed perpendicular to the project baseline every 50 ft beginning and ending at the terminal points shown in the plans. Each cross section shall extend 70' in both directions perpendicular to the baseline. The cross sections shall include all points of inflection and any abrupt changes in elevation along the cross section of the channel.

### 6.4 Magnetometer Survey

At a minimum, magnetometer surveys shall be conducted along the centerline of the channel to be excavated as stated in Section 6.3.2 "Channel Cleanout". The magnetometer lines shall accurately cover the entire proposed excavated area, so that any existing pipelines will be detected. Horizontal coordinates (Louisiana State Plane, U.S. feet, NAD 83), frequency, and duration of each magnetic anomaly shall be recorded. For each magnetic anomaly encountered, it shall determine whether or not that anomaly represents a pipeline. Should the anomaly does represent a pipeline, the bearing of said pipe, depth of cover, and the elevation of the top of the pipeline must be determined.

## 6.5 Deliverables

The Magnetometer Survey shall include a report outlining the results and description of the magnetometer survey, including the magnetic anomalies and information about any pipelines detected, including the locations and depths of said pipelines. Three hard copies of the report shall be provided and two digital copies provided in Autocad (.dwg format) or an approved equal. The digital copies shall include an Adobe (.pdf format) version of the report and the Point Files (.csv or .txt format) of the locations of any pipelines found within the borrow area.

The post-construction survey shall be stamped by a professional surveyor licensed in the State of Louisiana. The post-construction survey drawings shall be submitted to the Engineer for review and approval by the date provided in SP-3. Three copies shall be provided on 11" x 17" paper and two digital copies provided in AutoCAD (.DWG format) or an approved equal. The digital copies shall include an Adobe (.pdf format) version of the survey drawings and the Point Files (.csv or .txt format) of the post-construction survey.

## 6.6 Measurement and Payment

Payment for the Construction Survey shall be received once all deliverables specified in Section 5.4 have been received by the Owner. All costs associated with the Construction Survey, including the Contractor's Equipment, magnetometer survey, personnel, materials, components and those of his/her Subcontractors and such others' costs as may be denoted in the Contract Documents shall be paid for on a lump sum basis as per Bid Item No.5 "Construction Survey".

**END OF PART III – TECHNICAL SPECIFICATIONS**

**APPENDIX A: CLARIFICATION, CHANGE ORDERS, AND ACCEPTANCE FORMS**

ATTACHMENT A1

HIGHWAY 384 HYDROLIC RESOTRATION PROJECT-MAINTENANCE EVENT  
(CS-21)

Interpretation or Clarification by Engineer  
Number ( \_\_\_\_ )

DATE:

SUBJECT:

SUMMARY OF MATTER BY CONTRACTOR

---

INTERPRETATION OR CLARIFICATION OF MATTER BY ENGINEER

---

ATTACHMENT A2

**CHANGE ORDER NO. # \_\_\_\_\_**

**OWNER:** State of Louisiana, Coastal Protection and Restoration Authority  
**CONTRACTOR:** \_\_\_\_\_  
**PROJECT:** Highway 384 Hydrologic Restoration Project-MAINTENANCE EVENT (CS-21)  
**FILE NO:** \_\_\_\_\_  
**PURCHASE ORDER NO:** \_\_\_\_\_  
**ENGINEER:** Royal Engineers & Consultants, LLC

The following changes are hereby proposed to made to the Contract Documents:

**Description:** See Attached Summary.

**Attachments (List Documents Supporting Change):**

| Change in Contract Price                            |    | Change in Contract Time                                    |  |
|---|----|--|--|
| Original Contract Price                             | \$ | Original Contract Time (Calendar Days)                     |  |
| Net Increase (Decrease) from Previous Change Orders | \$ | Net Increase (Decrease) from Previous Change Orders (Days) |  |
| Contract Price prior to this Change Order           | \$ | Contract Time prior to this Change Order (Calendar Days)   |  |
| Net Increase (Decrease) of this Change Orders       | \$ | Net Increase (Decrease) of this Change Order (Days)        |  |
| Contract Price with this Change Order               | \$ | Contract Time with this Change Order (Calendar Days)       |  |

**RECOMMENDED:**

By: \_\_\_\_\_  
 Engineer

Date: \_\_\_\_\_

**RECOMMENDED:**

By: \_\_\_\_\_  
 CPRA Construction Manager

Date: \_\_\_\_\_

**ACCEPTED:**

By: \_\_\_\_\_  
 Contractor

Date: \_\_\_\_\_



ATTACHMENT A3

**HIGHWAY 384 HYDROLIC RESOTRATION PROJECT-MAINTENANCE EVENT  
(CS-21)**

**FILE NO: \_\_\_\_\_, PURCHASE ORDER NO: \_\_\_\_\_**

**SUMMARY OF CHANGE ORDER NO. \_\_\_\_\_**

| <b>Item No.</b>                                     | <b>Description</b> | <b>Unit</b> | <b>Original Quantity</b> | <b>Adjusted Quantity</b> | <b>Unit Price</b> | <b>Amount Overrun</b> | <b>Amount Underrun</b> |
|---|--------------------|-------------|--------------------------|--------------------------|-------------------|-----------------------|------------------------|
|   |                    |             |                          |                          |                   |                       |                        |
|   |                    |             |                          |                          |                   |                       |                        |
|   |                    |             |                          |                          |                   |                       |                        |
|   |                    |             |                          |                          |                   |                       |                        |
|   |                    |             |                          |                          |                   |                       |                        |
| Total Amount Overrun:                               |                    |             |                          |                          |                   |                       | \$                     |
| Total Amount Underrun:                              |                    |             |                          |                          |                   |                       | \$                     |
| <b>Net Increase (Decrease) of this Change Order</b> |                    |             |                          |                          |                   |                       | <b>\$</b>              |

**JUSTIFICATION:**

No reduction of/additional contract time is requested to accomplish the work for the change order.

ATTACHMENT A4

**\*NOT FOR RECORDATION PURPOSES\***

**RECOMMENDATION OF ACCEPTANCE**

TO: Coastal Protection and Restoration Authority  
450 Laurel Street, Suite 1501  
Baton Rouge, LA 70801

From: \_\_\_\_\_  
\_\_\_\_\_  
\_\_\_\_\_  
*Design Firm Name and Address*

DATE: \_\_\_\_\_

PROJECT NAME & NUMBER: \_\_\_\_\_

SITE CODE: \_\_\_\_\_ STATE ID: \_\_\_\_\_ CFMS: \_\_\_\_\_

CONTRACTOR: \_\_\_\_\_  
\_\_\_\_\_

ORIGINAL CONTRACT AMOUNT: \$ \_\_\_\_\_

FINAL CONTRACT AMOUNT: \$ \_\_\_\_\_

DATE OF ACCPETANCE: \_\_\_\_\_

CONTRACT DATE OF COMPLETION: \_\_\_\_\_

NUMBER OF DAYS (OVERRUN) (UNDERRUN) (As of Acceptance Date): \_\_\_\_\_

LIQUIDATED DAMAGES PER DAY AS STIPULATED IN CONTRACT \$ \_\_\_\_\_

VALUE OF PUNCH LIST \$ \_\_\_\_\_  
*(Attach Punch List)*

Signed: \_\_\_\_\_  
Designer

*FOR USE OF PROJECT MANGER*



Signed: \_\_\_\_\_  
Project Manager

**\*NOT FOR RECORDATION PURPOSES\***





**APPENDIX B: LANDRIGHTS MEMORANDUM**

**Exhibit A**  
**Highway 384**  
**Hydrologic Restoration**  
**(CS-21)**  
 Cameron Parish, La

**Legend**

-  Proposed Dredging Area
-  Portion of Project Footprint
-  Section Line

**Land Owner**

-  State-claimed Waterbottom
-  Calcasieu Lake Development
-  Hebert, et al
-  Smythe, et al

All project features are graphical representations only, are subject to change, and may not reflect true location or dimension

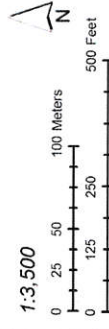

Source: Coastal Protection and Restoration Authority of Louisiana  
 Imagery: 2013 NAIP DOQQ  
 Map Date: April 15, 2014  
 2014040715

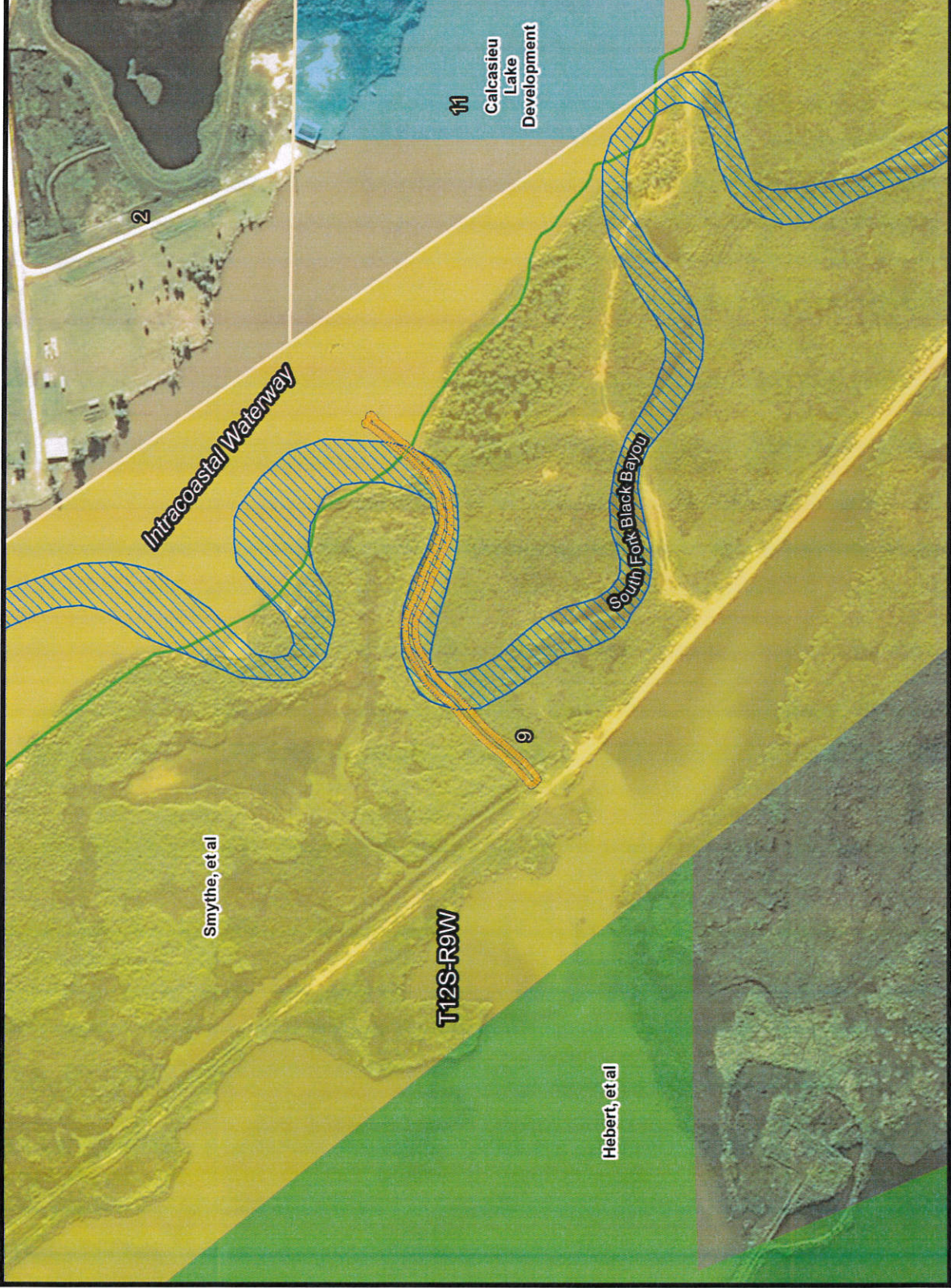

**LANDOWNER INFORMATION**

| <b>Name</b>                                  | <b>Address</b>                                   |
|--|--|
| Cottingin, Dozie Marie                       | Star Route 1 Box 108, Reeves, LA 70658           |
| Norwood, George Alton                        | 2343 Magnolia Church Rd., Ragley, LA 70657       |
| Norwood, Danny                               | 2704 Shasta Circle, Sulphur, LA 70663            |
| Abshire, Della N.                            | 7343 Olsen Rd., Sulphur, LA 70663                |
| Fruge, Kathy Arlene                          | 212 Landry St., Sulphur, LA 70663                |
| Cole, Eston - DECEASED                       | 915 Alamo St., Lake Charles, LA 70601            |
| Jackie Wix                                   | 810 Bee Tree, Westlake, LA 70669                 |
| Sliman, Shirley Ann                          | 115 South Elm Street, Welsh, LA 70591            |
| Guillot, Brenda                              | 440 WillowBrook Dr., Gretna, LA 70056            |
| Guidry, Reina                                | 7103 B MC Nickle, TAFB, OK 43145                 |
| Reeves, Barbara Jean                         | 807 Sunnyside Drive, Cloquet, MN 55720           |
| Norwood, Grady                               | P. O. Box 13501, Alexandria, LA 71463            |
| Norwood, Robert Auburn                       | Star Rt. 1, Box 108, Reeves, LA 70658            |
| Norwood, Wayne                               | P. O. Box 1640, Sulphur, LA 70664                |
| Alexander, Glenn W.                          | P. O. Box 250, Cameron, LA 70632                 |
| Devall, Ernest Gordon                        | 10439 Hwy. 384 Big Lake, L.C., LA 70607          |
| Devall, Earl Joseph                          | 416 University Dr., L. C., LA 70605-5630         |
| Geer, Betty                                  | 2612 Kirkman St., Lake Charles, LA 70601         |
| Lavergne, Floyd                              | 3544 Necess Rd., Lake Charles, LA 70605          |
| Leblue, Arsand                               | 9490 Lake Rd., Lake Charles, LA 70605            |
| Kay, Lori P. Poole                           | P. O. Box 281, Richlands, VA 24641               |
| Lyons, Lilly Faye                            | Rt. 4, Box 267, Church Point, LA 70525           |
| Norwood, Tan Kelly                           | 1101 Joe Miller Rd., Lake Charles, LA 70611-4405 |
| Norwood, John Charles Raleigh                | P. O. Box 284, Westlake, LA 70669                |
| Norwood, Floyd Samuel                        | 2508 Wilda St., Westlake, LA 70669               |
| Norwood, Marvin Clyde                        | 31124 Davis Rd., Westlake, LA 70669              |
| Parish, Margie T., wife of and Jesse Parish  | 10431 Hwy. 384 Big Lake, L.C., LA 70607          |
| Tolbert, Dorothy                             | 152 Oliver St., Lake Charles, LA 70607           |
| Vidrine, Della Marie                         | 10421 Hwy. 384 Big Lake, L.C., LA 70607          |
| Weir, Bonnie Dee                             | P. O. Box 614, Iowa, LA 70647                    |
| Zimmerman, Clada Sue                         | 720 Sabre Drive, Lake Charles, LA 70611          |
| Fontenot, Ena                                | 912 North Claiborne St., Sulphur, LA 70663       |
| Kibodeaux, Opal N.                           | 7105 Hwy. 27, Sulphur, LA 70665                  |
| Lejeune, Gail D.                             | 2781 Southern Dr., Lake Charles, LA 70611-4309   |
| Norwood, W. S.                               | Box 1423, Bridge City, TX 77611                  |
| Stevenson, Jr., John "Buck"                  | 10871 Big Lake Hwy. 384 Lake Charles, LA 70607   |
| Precht, Ethel, wife of and Charles H. Precht | 183 West Precht Rd., Bell City, LA 70630         |
| Romero, Daisy Askew                          | 105 Oliver St., Lake Charles, LA 70607           |
| Smythe, Sandra                               | 10345 Hwy. 384 Big Lake, L. C., LA 70607         |

**LANDOWNER INFORMATION**

| <b>Name</b>                    | <b>Address</b>                            |
|--------------------------------|---|
| Sargent Mattison, Brian        | 9403 Nash Lane, Lake Charles, LA 70607    |
| Henry, Caroline C.             | 7294 S. Hwy. 27, Sulphur, LA 70663        |
| Goodrich, Opal D.              | 7290 S. Hwy. 27, Sulphur, LA 70663        |
| Smythe, Marck P. Dr. (dentist) | Box 119, Creole, LA 70632                 |
| Reed, Evelyn                   | P. O. Box 206-S, Hackberry, LA 70645      |
| Mr. Ellis Nunez                | 135 Betty Murle Lane, Bell City, LA 70606 |

**APPENDIX C: GOVERNMENT PERMITS**



DEPARTMENT OF THE ARMY  
NEW ORLEANS DISTRICT, CORPS OF ENGINEERS

P. O. BOX 60267

NEW ORLEANS, LOUISIANA 701600267

REPLY TO  
ATTENTION OF:

Operations Division  
Western Evaluation Section

NOV 25 2014

**Subject:** MVN-1997-01389-WLL

Cameron Parish Gravity Drainage District # 8  
1160 Hwy. 384  
Lake Charles, LA 76607

Gentlemen:

The proposed work: to conduct maintenance dredging of the existing freshwater diversion channel of CWPPRA Project CS-21 at Hwy 384 in Cameron Parish, Louisiana, as shown on the enclosed drawings; is authorized under **Category II** of the **Programmatic General Permit**, provided that all conditions of the permit are met.

The following special condition is made part of this authorization:

The permittee is advised that the work/activities covered by this permit will take place over Government-owned easement areas. As such, be advised that the United States shall in no case be liable for any damage or injury to the construction and/or operation and maintenance herein authorized which may be caused by any action of the Government, under the rights obtained in its easements, either hidden or known, or that may result from future operations undertaken by the Government, and no claim or right to compensation shall accrue from such damage or injury, and if further operations of the United States require the ceasing of activities and/or the alteration or removal of the structures herein, the permittee shall, upon due notice from the Chief of Engineers, Department of the Army, cease activities and/or alter or remove said structures without expense to the Government and subject to the supervision and approval of the officer having jurisdiction over the property, and no claim for damages shall be made against the United States on account of such ceasing of activities and/or removal or alteration of structures.

Prior to commencing work on your project, you must obtain approvals from state and local agencies as required by law and by terms of this permit. These approvals include, but are not limited to, a permit, consistency determination, or determination of "no direct or significant impact (NDSI) on coastal waters" from the Louisiana Department of Natural Resources, Office of Coastal Management and a water quality certification from the Louisiana Department of Environmental Quality.



This approval to perform work is valid for 5 years from the date of this letter.

Permittee is aware that this office may reevaluate its decision on this permit at any time the circumstances warrant.

Should you have any further questions concerning this matter, please contact Michael Herrmann of this office at (504) 862-1954 or at Michael.h.herrmann@usace.army.mil

Sincerely,

A handwritten signature in black ink, appearing to read "Martin S. Mayer".

 Martin S. Mayer  
Chief, Regulatory Branch  
Operations Division

Enclosure

1. Activities authorized under this general permit shall not be used for piecemeal work and shall be applied to single and complete projects. All components of a single and complete project shall be treated together as constituting one single and complete project. All planned phases of multi-phased projects shall be treated together as constituting one single and complete project. This general permit shall not be used for any activity that is part of an overall project for which an individual permit is required.
2. No activity is authorized under this general permit which may adversely affect significant cultural resources listed or eligible for listing in the National Register of Historic Places until the requirements for Section 106 of the National Historic Preservation Act are met. Upon discovery of the presence of previously unknown historic and/or prehistoric cultural resources, all work must cease and the permittee must notify the State Historic Preservation Office and the Corps of Engineers. The authorization is suspended until it is determined whether or not the activity will have an adverse effect on cultural resources. The authorization may be reactivated or modified through specific conditions if necessary, if it is determined that the activity will have no adverse effect on cultural resources. The CEMVN-PGP authorization will be revoked if it is determined that cultural resources would be adversely affected, and an individual permit may be necessary.
3. The Chitimacha Tribe of Louisiana has stated that the project area is part of the aboriginal Chitimacha homelands. If during the course of work at the site, prehistoric and/or historic aboriginal cultural materials are discovered, the permittee will contact the Chitimacha Tribe of Louisiana at P.O. Box 661, Charenton, LA 70523, and CEMVN. CEMVN will initiate the required Federal, State, and Tribal coordination to determine the significance of the cultural materials and the need, if applicable, for additional cultural resource investigations.
4. There shall be no unreasonable interference with navigation by the existence or use of the activity authorized herein. The permittee will, at his or her expense, install and maintain any safety lights, signals, and signs prescribed by the United States Coast Guard, through regulations or otherwise, on authorized facilities or on equipment used in performing work under the authorization.
5. No activity may substantially disrupt the movement of those species of aquatic life indigenous to the water body, including those species which normally migrate through the area, unless the activity's primary purpose is to block or impound water.
6. If the proposed activity involves the installation of aerial transmission lines, submerged cable, or submerged pipelines across navigable waters of the United States the following is applicable:

The National Ocean Service (NOS) has been notified of this authorization. You must notify NOS and this office in writing, at least two weeks before you begin work and upon completion of the activity authorized by this permit. Your notification of completion must include a drawing which certifies the location and configuration of the completed activity (a certified permit drawing may be used). Notification to NOS will be sent to the following address: National Ocean Service, Office of Coast Survey, N/CS261, 1315 East West Highway, Silver Springs, Maryland 20910-3282.
7. For pipelines under an anchorage or a designated fairway in the Gulf of Mexico the following is applicable: The NOS has been notified of this authorization. You must notify NOS and this office in writing, at least two weeks before you begin work and upon completion of the activity authorized by this permit. Within 30 days of completion of the pipeline, 'as built' drawings certified by a professional engineer registered in Louisiana or by a registered surveyor shall be furnished to this office, the Commander (dpw), Eighth Coast Guard District, Hale Boggs Federal Building, 500 Poydras Street, Room 1230, New Orleans, Louisiana 70130, and to the Director, National Ocean Service, Office of Coast Survey, N/CS261, 1315 East West Highway, Silver Springs, Maryland 20910-3282. The plans must include the location, configuration and actual burial depth of the completed pipeline project.

8. If the proposed project, or future maintenance work, involves the use of floating construction equipment (barge mounted cranes, barge mounted pile driving equipment, floating dredge equipment, dredge discharge pipelines, etc.) in the waterway, you are advised to notify the Eighth Coast Guard District so that a Notice to Mariners, if required, may be prepared. Notification with a copy of your permit approval and drawings should be mailed to the Commander (dpw), Eighth Coast Guard District, Hale Boggs Federal Building, 500 Poydras Street, Room 1230, New Orleans, Louisiana 70130, about 1 month before you plan to start work. Telephone inquiries can be directed to the Eighth Coast Guard District, Waterways Management at (504) 671-2107.
9. All activities authorized herein shall, if they involve, during their construction or operation, any discharge of pollutants into waters of the United States, be at all times consistent with applicable water quality standards, effluent limitations and standards of performance, prohibitions, pretreatment standards and management practices established pursuant to the Clean Water Act (PL 92-500:86 Stat 816), or pursuant to applicable state and local laws.
10. Substantive changes to the Louisiana Coastal Resources Program may require immediate suspension and revocation of this permit in accordance with 33 CFR 325.7.
11. Irrespective of whether a project meets the other conditions of this permit, the Corps of Engineers retains discretionary authority to require an individual Department of the Army permit when circumstances of the proposal warrant this requirement.
12. Any individual authorization granted under this permit may be modified, suspended, or revoked in whole or in part if the Secretary of the Army or his authorized representative determines that there has been a violation of any of the terms or conditions of this permit or that such action would otherwise be in the public interest.
13. The Corps of Engineers may suspend, modify, or revoke this general permit if it is found in the public interest to do so.
14. Activities proposed for authorization under the PGP must comply with all other necessary federal, state, and/or local permits, licenses, or approvals. Failure to do so would result in a violation of the terms and conditions of CEMVN-PGP.
15. The permittee shall permit the District Commander or his authorized representative(s) or designee(s) to make periodic inspections of the project site(s) and disposal site(s) if different from the project site(s) at any time deemed necessary in order to assure that the activity being performed under authority of this permit is in accordance with the terms and conditions prescribed herein.
16. This general permit does not convey any property rights, either in real estate or material, or any exclusive privileges; and it does not authorize any injury to property or invasion of rights or any infringement of federal, state, or local laws or regulations nor does it obviate the requirements to obtain state or local assent required by law for the activity authorized herein.
17. In issuing authorizations under this permit, the federal government will rely upon information and data supplied by the applicant. If, subsequent to the issuance of an authorization, such information and data prove to be false, incomplete, or inaccurate, the authorization may be modified, suspended, or revoked, in whole or in part.
18. For activities resulting in sewage generation at the project site, such sewage shall be processed through a municipal sewage treatment system or, in areas where tie-in to a municipal system is not practical, the on-site sewerage system must be approved by the local parish sanitarian before construction.
19. Any modification, suspension, or revocation of CEMVN-PGP, or any individual authorization granted under this permit, will not be the basis for any claim for damages against the United States.

20. Additional conditions deemed necessary to protect the public interest may be added to the general permit by the District Commander at any time. If additional conditions are added, the public will be advised by public notice. Individual authorizations under CEMVN-PGP may include special conditions deemed necessary to ensure minimal impact and compliance with CEMVN-PGP.

21. CEMVN-PGP is subject to periodic formal review by CEMVN and OCM in coordination with the Environmental Protection Agency, US Fish and Wildlife Service, the National Marine Fisheries Service, and the Louisiana Department of Wildlife and Fisheries. Comments from reviewing agencies will be considered in determination as to whether modifications to the general permit are needed. Should the District Commander make a determination not to incorporate a change proposed by a reviewing agency, after normal negotiations between the respective agencies, the District Commander will explain in writing to the reviewing agency the basis and rationale for his decision.

22. CEMVN retains discretion to review CEMVN-PGP, its terms, conditions, and processing procedures, and decide whether to modify, reissue, or revoke the permit. If CEMVN-PGP is not modified or reissued within 5 years of its effective date, it automatically expires and becomes null and void.

23. The permittee understands and agrees that, if future operations by the United States require the removal, relocation, or other alteration, of the structure or work herein authorized, or if, in the opinion of the Secretary of the Army or his authorized representative, said structure or work shall cause unreasonable obstruction to the free navigation of the navigable waters, the permittee will be required, upon due notice from the Corps of Engineers, to remove, relocate, or alter the structural work or obstructions caused thereby, without expense to the United States. No claim shall be made against the United States on account of any such removal or alteration.

24. You must maintain the activity authorized by this permit in good condition and in conformance with the terms and conditions of this permit. You are not relieved of this requirement if you abandon the permitted activity, although you may make a good faith transfer to a third party as described in Special Condition 26 below. Should you wish to cease to maintain the authorized activity or should you desire to abandon it without a good faith transfer, you must obtain a modification of this permit from this office, which may require restoration of the area.

25. If you discover any previously unknown historic or archeological remains while accomplishing the activity authorized by this permit, you must immediately notify this office of what you have found. We will initiate the Federal and State coordination required to determine if the remains warrant a recovery effort or if the site is eligible for listing in the National Register of Historic Places.

26. If you sell the property associated with this permit, you must provide this office with a copy of the permit and a letter noting your agreement to transfer the permit to the new owner and the new owner's agreement to accept the permit and abide by all conditions of the permit. This letter must be signed by both parties.

27. If a conditioned water quality certification has been issued for your project, you must comply with the conditions specified in the certification as special conditions to this permit.

28. Many local governing bodies have instituted laws and/or ordinances in order to regulate dredge and/or fill activities in floodplains to assure maintenance of floodwater storage capacity and avoid disruption of drainage patterns that may affect surrounding properties. Your project involves dredging and/or placement of fill; therefore, you must contact the local municipal and/or parish governing body regarding potential impacts to floodplains and compliance of your proposed activities with local floodplain ordinances, regulations or permits.

29. In issuing authorizations under this permit, the federal government does not assume any liability for: damages to the permitted project or uses thereof as a result of other permitted or unpermitted activities or from natural causes; damages to the permitted project or uses thereof as a result of current or future activities undertaken by or on behalf of the United States in the public interest; damages to persons, property, or to other permitted or unpermitted activities or structures caused by the activity authorized by this permit, and; design or construction deficiencies associated with the permitted work.

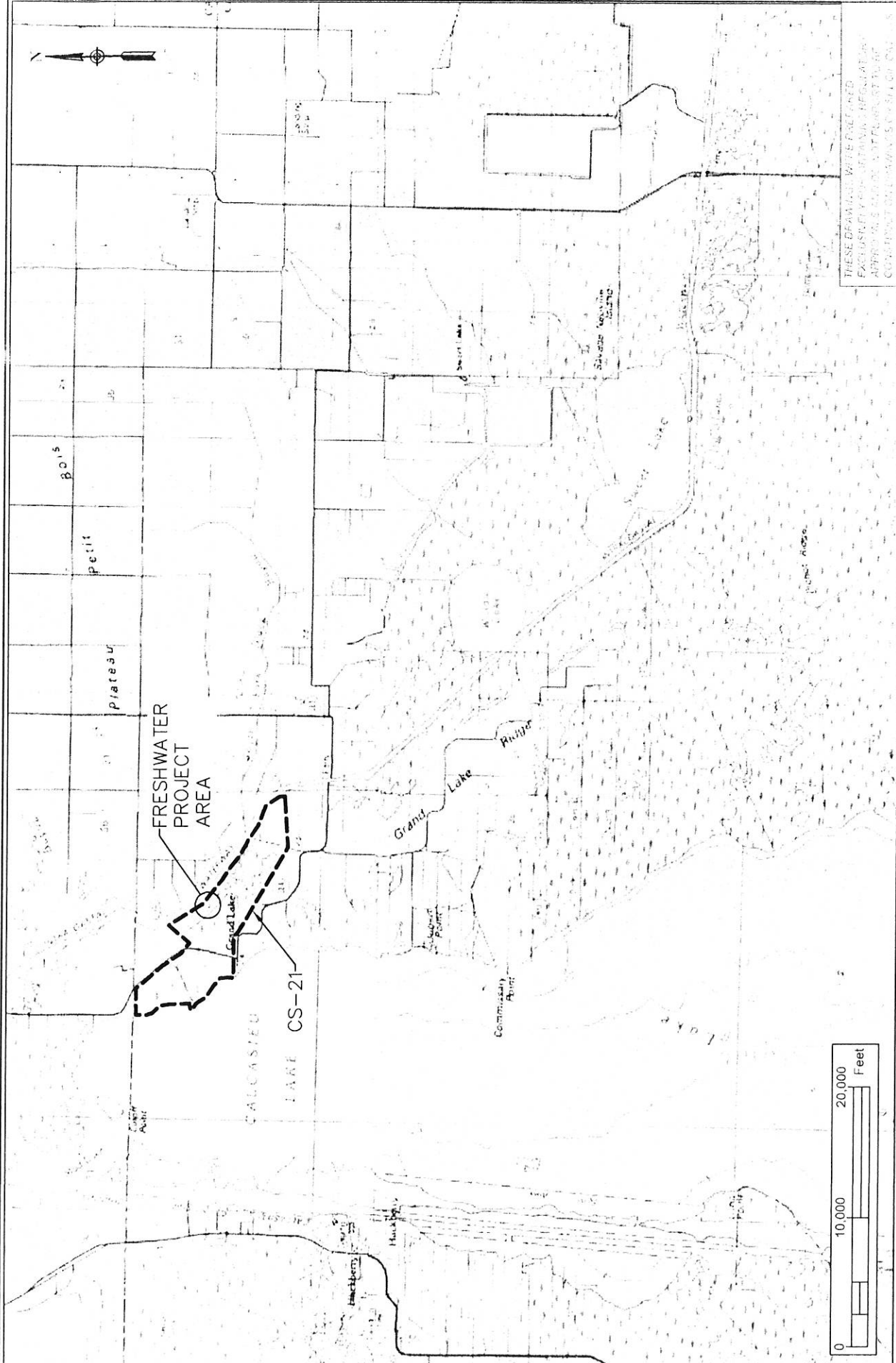

THESE ÉBAUCHES SONT PRÉPARÉES  
 EXCLUSIVEMENT À L'INTENTION DE L'APPRIÉTIÉ  
 APPRÉHENSIONNÉ ET NE DOIVENT PAS ÊTRE  
 CONSIDÉRÉES COMME UN DOCUMENT OFFICIEL

|            |    |                                  |           |
|------------|----|----------------------------------|-----------|
| PROJ. NAME |    | WAVY BAY HYDROLOGIC REGISTRATION |           |
| DES.       | LL | SCALE                            | AS SHOWN  |
| DR.        | LL | DIN No.                          | 2014-002  |
| CH.        | BT | DATE                             | 5/12/2014 |
| APP.       | BT | SHEET NO.                        | 1 OF 5    |

| REV | DATE | DESCRIPTION | BY | CLIENT |
|-----|------|-------------|----|--------|
|     |      |             |    |        |
|     |      |             |    |        |
|     |      |             |    |        |
|     |      |             |    |        |



**ROYAL ENGINEERS  
& CONSULTANTS, LLC**  
 1231 Canadella Boulevard  
 Lafayette, LOUISIANA 70508



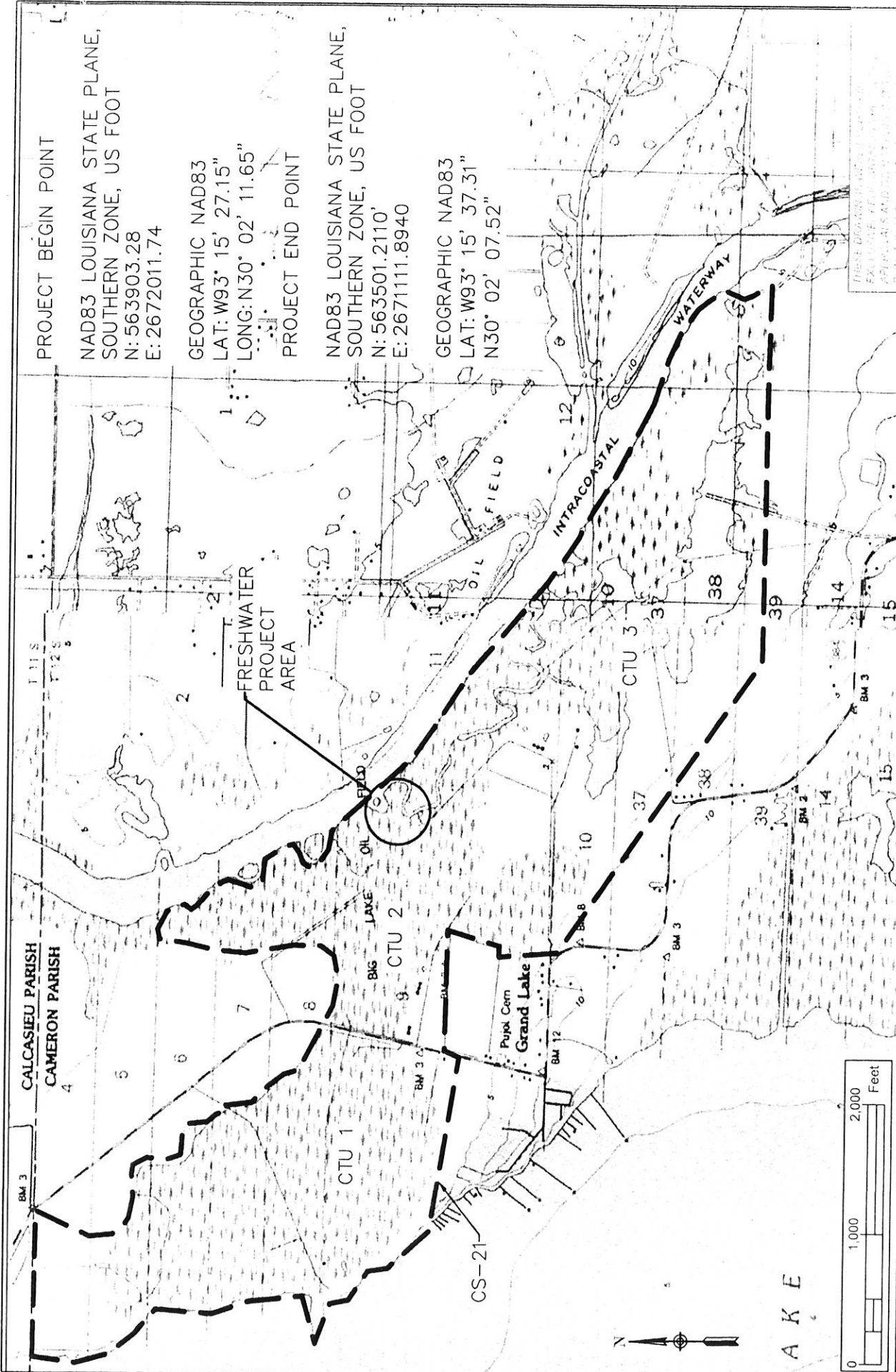

PROJECT BEGIN POINT

NAD83 LOUISIANA STATE PLANE,  
SOUTHERN ZONE, US FOOT  
N: 563903.28  
E: 2672011.74

GEOGRAPHIC NAD83  
LAT: W93° 15' 27.15"  
LONG: N30° 02' 11.65"

PROJECT END POINT

NAD83 LOUISIANA STATE PLANE,  
SOUTHERN ZONE, US FOOT  
N: 563501.2110  
E: 2671111.8940

GEOGRAPHIC NAD83  
LAT: W93° 15' 37.31"  
LONG: N30° 02' 07.52"



|            |                               |              |            |
|------------|-------------------------------|--------------|------------|
| TITLE      |                               | LOCATION MAP |            |
| PROJ. NAME | MAIN BRANCH ROAD IMPROVEMENTS | DATE         | 11/11/14   |
| DES.       | JL                            | SCALE        | AS SHOWN   |
| JR         | EL                            | JOB NO.      | 1400000000 |
| CHK.       | EL                            | DRAWN        | EL         |
| APP.       | EL                            | DATE         | 5/14/14    |
|            |                               | SHEET NO.    | 2 OF 4     |
|            |                               | REV.         |            |

| REV. | DATE | DESCRIPTION | BY | CLIENT |
|------|------|-------------|----|--------|
|      |      |             |    |        |
|      |      |             |    |        |
|      |      |             |    |        |
|      |      |             |    |        |



**CPRA**



**ROYAL ENGINEERS  
& CONSULTANTS, LLC**  
1231 Camellia Boulevard  
Lafayette, LOUISIANA 70508

FILE



BEGIN FRESHWATER  
CHANNEL CLEAN OUT  
N: 563903.28  
E: 2672011.74

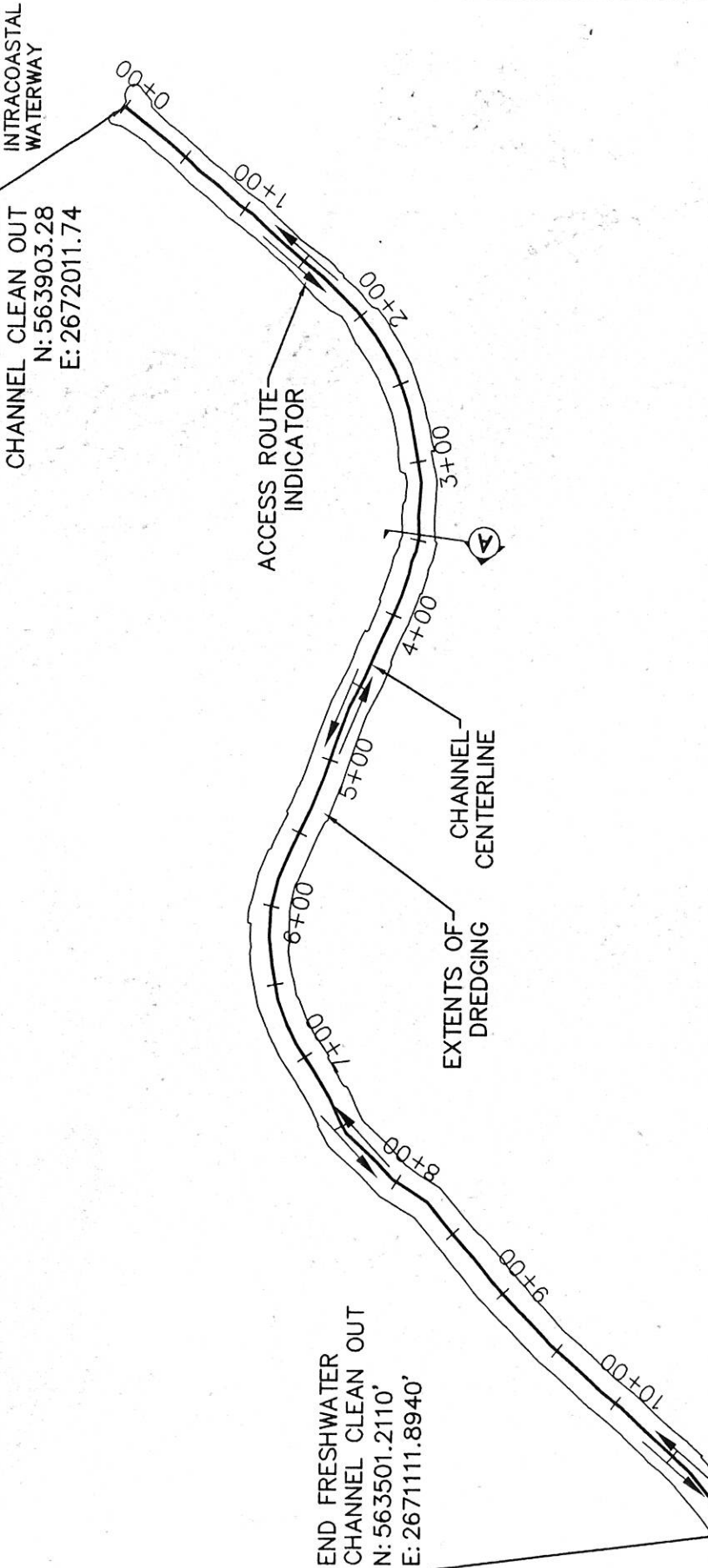

NOTE:  
APPROXIMATELY 1,116  
LINEAR FEET TO BE  
EXCAVATED.



|            |          |           |     |
|------------|----------|-----------|-----|
| TITLE      |          | PLAN VIEW |     |
| PROJ. NAME | SCALE    | SHEET NO  | REV |
| DES        | AS SHOWN | 3 OF 5    |     |
| DR         |          |           |     |
| CHK        |          |           |     |
| APP        |          |           |     |

| REV | DATE | DESCRIPTION | BY | CLIENT |
|-----|------|-------------|----|--------|
|     |      |             |    |        |
|     |      |             |    |        |
|     |      |             |    |        |
|     |      |             |    |        |



**ROYAL ENGINEERS  
& CONSULTANTS, LLC**  
1231 Camellia Boulevard  
Lafayette, LOUISIANA 70508



FILE:

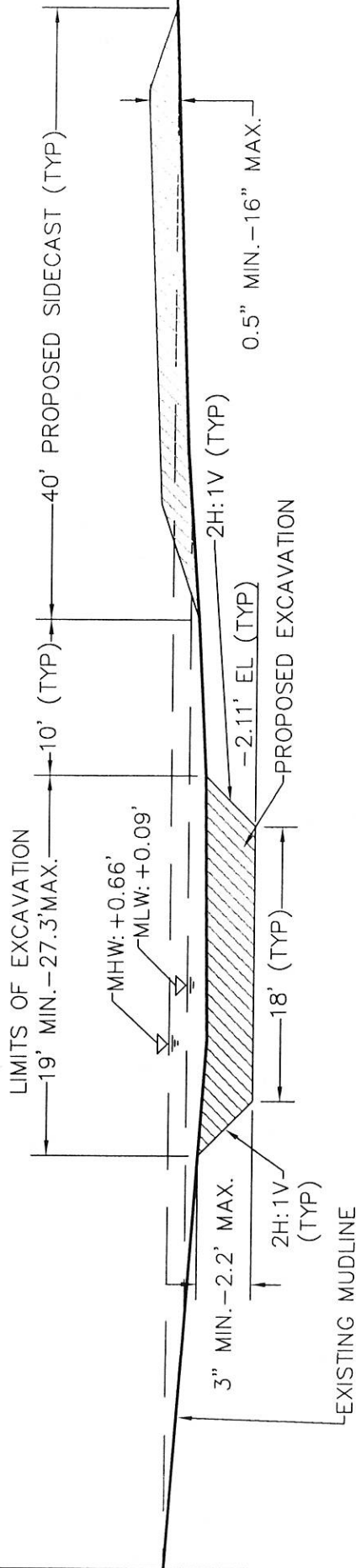

TYPICAL SECTION A  
 HORIZONTAL SCALE: 1"=10'  
 VERTICAL SCALE: 1"=5'

- NOTE:
1. ALL ELEVATIONS REFERENCED IN NAVD88 - GEOID 12A
  2. APPROXIMATELY 1,057 CUBIC YARDS TO BE EXCAVATED.
  3. APPROXIMATELY 1,116 LINEAR FEET TO BE EXCAVATED.



**ROYAL ENGINEERS  
& CONSULTANTS, LLC**  
 1231 Camellia Boulevard  
 Lafayette, LOUISIANA 70508

| REV. | DATE | DESCRIPTION | BY | CHKD. |
|------|------|-------------|----|-------|
|      |      |             |    |       |
|      |      |             |    |       |
|      |      |             |    |       |



| TITLE     |                        |
|-----------|------------------------|
| REG. NAME | APP. NO. APPROVAL DATE |
| DES.      | SCALE AS SHOWN         |
| DR.       | JOB NO.                |
| APP.      | DATE                   |
|           |                        |
|           |                        |
|           |                        |
|           |                        |

TYPICAL CROSS-SECTION



GENERAL NOTES:

1. ALL ELEVATIONS ARE GIVEN IN THE NORTH AMERICAN VERTICAL DATUM OF 1988 (NAVD88) U.S. SURVEY FEET. ALL HORIZONTAL COORDINATES ARE GIVEN IN THE NORTH AMERICAN DATUM OF 1983 (NAD83) LOUISIANA STATE PLANE SOUTH ZONE U.S. FEET.
2. THE CONTRACTOR SHALL CALL LOUISIANA ONE CALL AT 1-800-272-3020 A MINIMUM OF 5 WORKING DAYS PRIOR TO THE CONSTRUCTION TO LOCATE EXISTING UTILITIES AT THE PROJECT SITE.
3. CONTRACTOR SHALL IDENTIFY AND MARK THE CONSTRUCTION AREA ACCORDING TO THE LINES AND GRADES AS SET FORTH IN THE PLANS TO ESTABLISH AND MAINTAIN QUALITY CONTROL FOR EMBANKMENT CONSTRUCTION OPERATIONS TO ENSURE COMPLIANCE WITH CONTRACT REQUIREMENTS. AFTER FINAL ACCEPTANCE THE CONTRACTOR SHALL REMOVE MARKERS FROM CONTRACT LIMITS.
4. THE MAXIMUM DEPTH TO BE DREDGED SHALL BE NO GREATER THAN -2.11' FEET ELEVATION.
5. THESE DRAWINGS WERE PREPARED EXCLUSIVELY FOR OBTAINING REGULATORY APPROVALS AND DO NOT PURPORT TO BE CONSTRUCTION DRAWINGS OR SPECIFICATIONS.
6. ALL VESSELS USED SHALL HAVE A DRAFT NO GREATER THAN 2' WHEN FULLY LOADED.



**ROYAL ENGINEERS  
& CONSULTANTS, LLC**  
1231 Camellia Boulevard  
Lafayette, LOUISIANA 70508

| REV | DATE | DESCRIPTION | BY | CLIENT |
|-----|------|-------------|----|--------|
|     |      |             |    |        |
|     |      |             |    |        |
|     |      |             |    |        |
|     |      |             |    |        |



**GENERAL NOTES**

|              |                               |
|--------------|-------------------------------|
| PROJECT NAME | RAY, THE ANTONIO OLIVERA TRIP |
| REV          | 11                            |
| DATE         | 11                            |
| SCALE        | AS SHOWN                      |
| JOB No.      | 2011000000                    |
| APP          | BT                            |
| DATE         | 5/1/2014                      |
| SHEET NO.    | 5 OF 5                        |
| REV.         |                               |

**APPENDIX D: SURVEY CONTROL**

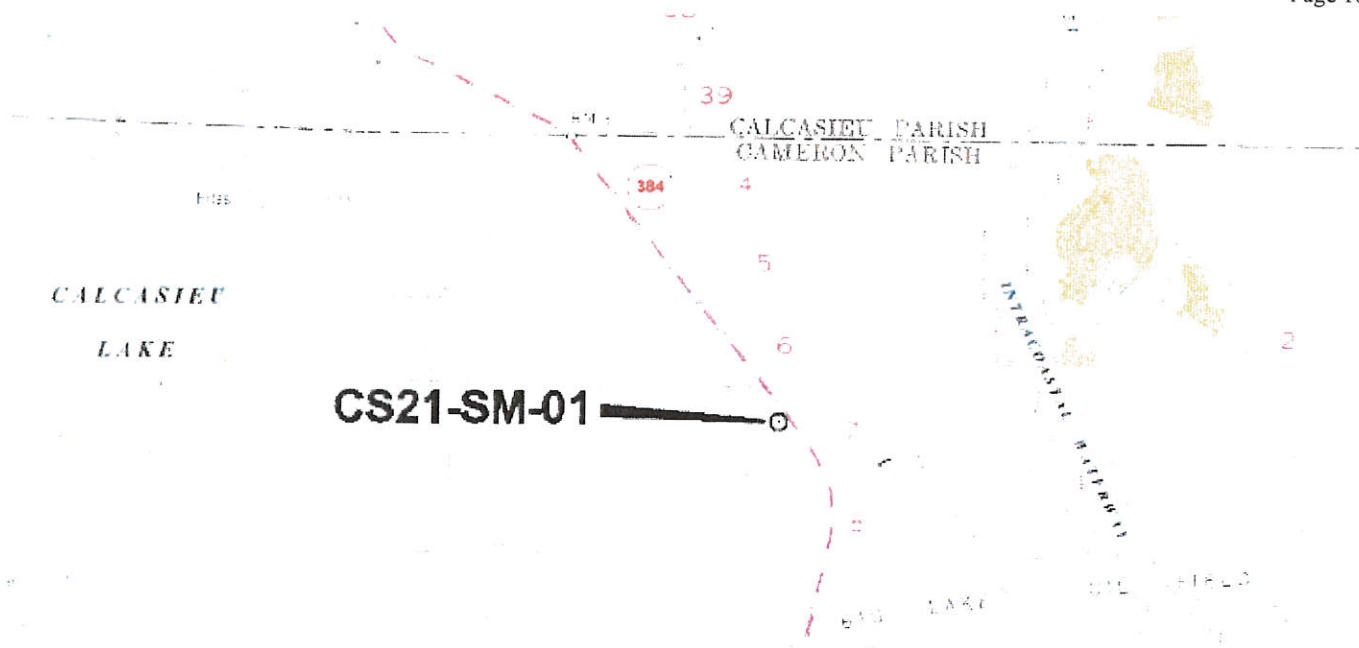

**VICINITY MAP** Scale: 1" = 2000'

Reproduced from USC&GS "MOSS LAKE" Quadrangle

**Station Name: CS21-SM-01**

**Monument Location:** From the Sweet Lake Draw Bridge on La. Hwy. 384 crossing the Intracoastal Waterway in Grand Lake, Louisiana, proceed westerly on La. Highway 384 for approximately 4.4 miles to monument at left on west side of highway.

**Monument Description:** Top Security Style Monument; 2" aluminum cap on 5/8" stainless steel rod driven to refusal, set in 6" PVC sleeve with concrete filled with sand.

**Stamping:** "384 N"

**Date:** October 2000

**Monument Established By:** John Chance Land Surveys, Inc

**For:** Louisiana Department of Natural Resources, CRD

**Re-Adjusted August 2001**

**Adjusted NAD 83 Geodetic Position (1992)**

Lat. 30° 02' 34.928209" N  
 Long. 93° 16' 16.770523" W

**Adjusted NAD 1983 Datum LSZ (1702) Ft**

N= 566,327.87  
 E= 2,667,691.03

**Adjusted NAVD88 Elevation**

2.90 Feet / 0.883 Mtrs.

Ellipsoid Height = -26.314m  
 Geoid99 Height = -27.197m



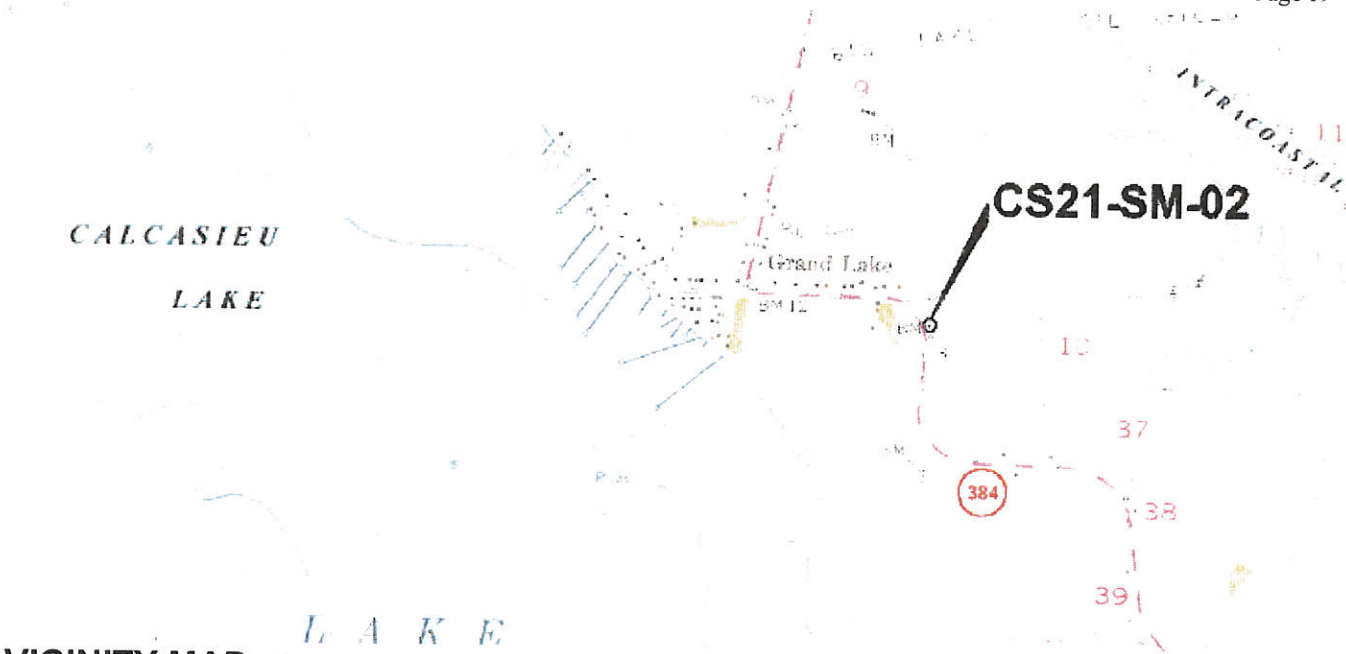

**VICINITY MAP** Scale: 1" = 2000'

Reproduced from USC&GS "MOSS LAKE" Quadrangle

**Station Name: CS-21-SM-02**

**Monument Location:** From the Sweet Lake Draw Bridge on La. Hwy. 384 crossing the Intracoastal Waterway in Grand Lake, Louisiana, proceed westerly on La. Highway 384 for approximately 3 miles to monument at right on east side of highway.

**Monument Description:** Top Security Style Monument; 2" aluminum cap on 5/8" stainless steel rod driven to refusal, set in 6" PVC sleeve with concrete filled with sand.

**Stamping:** "384 S"

**Date:** October 2000

**Monument Established By:** John Chance Land Surveys, Inc

*For: Louisiana Department of Natural Resources, CRD*

**Re-Adjusted August 2001**

**Adjusted NAD 83 Geodetic Position (1992)**

Lat. 30° 01' 43.450101" N  
 Long. 93° 15' 55.809834" W

**Adjusted NAD 1983 Datum LSZ (1702) Ft**

N= 561,097.31  
 E= 2,669,445.27

**Adjusted NAVD88 Elevation**

5.84eet / 1.779 mtrs

Ellipsoid Height = -25.395m  
 Geoid99 Height = -27.174m



## Benchmark Information

Station Name: CS21-SM-01

---

Stamping: "384 N"

---

### Adjusted NAD83 (2011) Epoch 2010 Geodetic Position:

Latitude: 30° 02' 34.92835" N

---

Longitude: 93° 16' 16.77063"

---

### Adjusted NAD83 (2011) Epoch 2010 LSZ (1702) Ft

Northing: 566327.88'

---

Eastin: 2667690.99'

---

Adjusted NAVD88 Elevation = 2.12 Feet/0.646 Meters

---

Ellipsoid Height = -26.432 m

---

Geoid12A Height = -27.197 m

---

**APPENDIX E: PREVAILING WAGE DETERMINATION SCHEDULE**

General Decision Number: LA140010 10/31/2014 LA10

Superseded General Decision Number: LA20130010

State: Louisiana

Construction Type: Heavy Elevated Storage Tank

Counties: Acadia, Allen, Ascension, Assumption, Avoyelles, Beauregard, Bienville, Bossier, Caddo, Calcasieu, Caldwell, Cameron, Catahoula, Claiborne, Concordia, De Soto, East Baton Rouge, East Carroll, East Feliciana, Evangeline, Franklin, Grant, Iberia, Iberville, Jackson, Jefferson Davis, La Salle, Lafayette, Lafourche, Lincoln, Livingston, Madison, Morehouse, Natchitoches, Ouachita, Plaquemines, Pointe Coupee, Rapides, Red River, Richland, Sabine, St Helena, St James, St Landry, St Martin, St Mary, Tangipahoa, Tensas, Terrebonne, Union, Vermilion, Vernon, Washington, Webster, West Baton Rouge, West Carroll, West Feliciana and Winn Counties in Louisiana.

ELEVATED STORAGE TANKS (Does not include JEFFERSON, ORLEANS, ST. BERNARD, ST. CHARLES, ST. JOHN THE BAPTIST, AND ST. TAMMANY PARISHES)

| Modification Number | Publication Date |
|---------------------|------------------|
| 0                   | 01/03/2014       |
| 1                   | 01/10/2014       |
| 2                   | 01/24/2014       |
| 3                   | 02/07/2014       |
| 4                   | 02/21/2014       |
| 5                   | 02/28/2014       |
| 6                   | 03/07/2014       |
| 7                   | 03/14/2014       |
| 8                   | 06/27/2014       |
| 9                   | 07/04/2014       |
| 10                  | 07/18/2014       |
| 11                  | 07/25/2014       |
| 12                  | 08/01/2014       |
| 13                  | 08/22/2014       |
| 14                  | 10/10/2014       |
| 15                  | 10/31/2014       |

BOIL0037-002 01/01/2014

Acadia, Allen, Assumption, Beauregard, Bienville, Bossier, Caddo, Calcasieu, Cameron, Claiborne, De Soto, Evangeline, Grant, Iberia, Jackson, Jefferson, Jefferson Davis, Lafayette, Lafourche, Lincoln, Natchitoches, Orleans, Plaquemines, Rapides, Red River, Sabine, St Bernard, St Charles, St James, St John the Baptist, St Landry, St Martin, St Mary, St Tammany, Tangipahoa, Terrebonne, Union, Vermilion, Washington, Webster, and Winn Parishes

|                  | Rates    | Fringes |
|------------------|----------|---------|
| BOILERMAKER..... | \$ 25.37 | 20.58   |
| -----            |          |         |

BOIL0582-002 01/20/2014

ASCENSION, AVOYELLES, CALDWELL, CATAHOULA, CONCORDIA, EAST BATON ROUGE, EAST CARROLL, EAST FELICIANA, FRANKLIN, IBERVILLE, LA SALLE, LIVINGSTON, MADISON, MOREHOUSE, OUACHITA, POINTE COUPEE, RICHLAND, ST. HELENA, TENSAS, WEST BATON ROUGE, WEST CARROLL, AND WEST FELICIANA PARISHES

|                  | Rates    | Fringes |
|------------------|----------|---------|
| BOILERMAKER..... | \$ 25.37 | 20.58   |

-----  
BRLA0001-003 06/01/2005

|                        | Rates    | Fringes |
|------------------------|----------|---------|
| Bricklayer, Stonemason |          |         |
| AREA 2.....            | \$ 20.55 | 5.75    |
| AREA 3.....            | \$ 19.95 | 6.35    |
| AREA 4.....            | \$ 20.25 | 6.05    |

AREA DEFINITIONS:

AREA 1 - Lake Charles Chapter Parishes: Acadia, Allen, Avoyelles, Beauregard, Calcasieu, Cameron, Catahoula, Concordia, Evangeline, Grant, Jefferson Davis, La Salle, Natchitoches, Pointe Coupee, Rapides, Sabine, St. Landry, Vernon, and Winn

AREA 2 - Baton Rouge Chapter Parishes: Ascension, Assumption, East Baton Rouge, East Feliciana, Iberia, Iberville, Lafayette, Livingston, St. Helena, St. Martin, St. Mary, Tangipahoa, Vermilion, Washington, West Baton Rouge, and West Feliciana

AREA 3 - Shreveport Chapter Parishes: Bienville, Bossier, Caddo, Caldwell, Claiborne, De Soto, East Carroll, Franklin, Jackson, Lincoln, Madison, Morehouse, Ouachita, Red River, Richland, Tensas, Union, Webster, and West Carroll

AREA 4 - New Orleans Chapter Parishes: Lafourche, Plaquemines, St. James, and Terrebonne

-----  
BRLA0001-009 06/01/2005

|                              | Rates    | Fringes |
|------------------------------|----------|---------|
| Pointer, caulker and cleaner |          |         |
| AREA 1.....                  | \$ 19.50 | 5.10    |
| AREA 2.....                  | \$ 20.55 | 5.75    |
| AREA 3.....                  | \$ 19.95 | 6.35    |
| AREA 4.....                  | \$ 20.25 | 6.05    |

AREA DEFINITIONS:

AREA 1 - Lake Charles Chapter Parishes: Acadia, Allen, Avoyelles, Beauregard, Calcasieu, Cameron, Catahoula, Concordia, Evangeline, Grant, Jefferson Davis, La Salle,



Natchitoches, Pointe Coupee, Rapides, Sabine, St. Landry, Vernon, and Winn

AREA 2 - Baton Rouge Chapter Parishes: Ascension, Assumption, East Baton Rouge, East Feliciana, Iberia, Iberville, Lafayette, Livingston, St. Helena, St. Martin, St. Mary, Tangipahoa, Vermilion, Washington, West Baton Rouge, and West Feliciana

AREA 3 - Shreveport Chapter Parishes: Bienville, Bossier, Caddo, Caldwell, Claiborne, De Soto, East Carroll, Franklin, Jackson, Lincoln, Madison, Morehouse, Ouachita, Red River, Richland, Tensas, Union, Webster, and West Carroll

AREA 4 - New Orleans Chapter Parishes: Lafourche, Plaquemines, St. James, and Terrebonne

-----  
CARP0729-001 07/01/2012

|                 | Rates    | Fringes |
|-----------------|----------|---------|
| MILLWRIGHT..... | \$ 25.80 | 9.50    |

-----  
CARP1098-002 07/01/2014

ASCENSION, ASSUMPTION, AVOYELLES, EAST BATON ROUGE, EAST FELICIANA, IBERIA, IBERVILLE, LIVINGSTON, POINT COUPEE, ST. HELENA, TANGIPAHOA, WEST BATON ROUGE, AND WEST FELICIANA PARISHES

|                    | Rates    | Fringes |
|--------------------|----------|---------|
| CARPENTER.....     | \$ 26.16 | 8.29    |
| PILEDRIVERMAN..... | \$ 26.16 | 8.29    |

-----  
CARP1098-007 07/01/2014

ACADIA, EVANGELINE, LAFAYETTE, ST. LANDRY, ST. MARTIN, ST. MARY AND VERMILLION PARISHES

|                    | Rates    | Fringes |
|--------------------|----------|---------|
| CARPENTER.....     | \$ 23.26 | 5.60    |
| PILEDRIVERMAN..... | \$ 23.26 | 5.60    |

-----  
CARP1098-008 07/01/2014

BIENVILLE, BOSSIER, CADDO, CATAHOULA, CALDWELL, CLAIBORNE, CONCORDIA, DE SOTO, EAST CARROLL, FRANKLIN, GRANT, JACKSON, LASALLE, LINCOLN, MADISON, MOREHOUSE, NATCHITOCHEs, OUACHITA, RAPIDES, RED RIVER, RICHLAND, SABINE, TENSAS, UNION, WEBSTER, WEST CARROLL AND WINN PARISHES

|                | Rates    | Fringes |
|----------------|----------|---------|
| CARPENTER..... | \$ 20.80 | 6.80    |

PILEDRIVERMAN.....\$ 20.80 6.80

-----  
CARP1098-013 07/01/2014

ALLEN, BEAUREGARD, CALCASIEU, CAMERON, JEFFERSON DAVIS AND  
VERNON PARISHES

Rates Fringes

CARPENTER.....\$ 26.16 6.80  
PILEDRIVERMAN.....\$ 26.16 6.80

-----  
CARP1846-004 07/01/2014

LAFOURCHE, PLAQUEMINES, ST. JAMES (South of the Mississippi  
River), TERREBONNE, and WASHINGTON PARISHES

Rates Fringes

Carpenter; piledriver.....\$ 23.46 8.05

-----  
ELEC0130-002 06/01/2014

ASSUMPTION, LAFOURCHE, PLAQUEMINES, ST. JAMES, ST. MARTIN  
(Southern Segment Only), ST. MARY (Northeast of the Atchafalaya  
River), AND TERREBONNE PARISHES

Rates Fringes

Electrician & Cable Splicer.....\$ 29.60 9.77

-----  
ELEC0194-003 09/02/2013

BIENVILLE, BOSSIER, CADDO, CLAIBORNE, DE SOTO, NATCHITOCHE  
(Northeast of the Red River), RED RIVER, and WEBSTER PARISHES

Rates Fringes

ELECTRICIAN  
Lineman and Heavy  
Equipment Operator.....\$ 25.50 3%+9.05

-----  
\* ELEC0446-003 09/01/2014

CALDWELL, EAST CARROLL, FRANKLIN, JACKSON, LINCOLN, MADISON,  
MOREHOUSE, OUACHITA, RICHLAND, TENSAS, UNION, AND WEST CARROLL  
PARISHES

Rates Fringes

ELECTRICIAN.....\$ 22.85 4%+9.09

-----  
ELEC0576-004 09/01/2014

AVOYELLES, CATAHOULA, CONCORDIA, EVANGELINE, GRANT, LA SALLE,  
NATCHITOCHE (Southwest of Red River), RAPIDES, SABINE, VERNON,

AND WINN PARISHES

|                  | Rates    | Fringes    |
|------------------|----------|------------|
| ELECTRICIAN..... | \$ 24.00 | 4.25%+6.25 |

\* ELEC0861-005 09/01/2014

ACADIA, ALLEN, BEAUREGARD, CALCASIEU, CAMERON, IBERIA, JEFFERSON DAVIS, LAFAYETTE, ST. MARTIN (Northern Segment Only), ST. MARY (Southwest of Atchafalaya River), AND VERMILION PARISHES

|                  | Rates    | Fringes |
|------------------|----------|---------|
| ELECTRICIAN..... | \$ 25.25 | 11.25   |

ELEC0995-004 01/01/2014

ASCENSION, EAST BATON ROUGE, EAST FELICIANA, IBERVILLE, LIVINGSTON, POINTE COUPEE, ST. HELENA, ST. LANDRY, WEST BATON ROUGE, AND WEST FELICIANA PARISHES

|                  | Rates    | Fringes |
|------------------|----------|---------|
| ELECTRICIAN..... | \$ 23.16 | 9.47    |

ELEC1077-001 06/01/2014

TANGIPAHOA and WASHINGTON PARISHES

|  | Rates    | Fringes |
|--|----------|---------|
| ELECTRICIAN (includes low voltage wiring)..... | \$ 22.80 | 7.50    |

ENGI0406-006 07/01/2010

ACADIA, ALLEN, AVOYELLES, BEAUREGARD, BIENVILLE, BOSSIER, CADDO, CALCASIEU, CALDWELL, CAMERON, CATAHOULA, CLAIBORNE, CONCORDIA, DESOTO, EAST CARROLL, EVANGELINE, FRANKLIN, GRANT, JACKSON, JEFFERSON DAVIS, LASALLE, LINCOLN, MADISON, MOREHOUSE, NATICHITOCHEs, OUACHITA, RAPIDES, RED RIVER, RICHLAND, SABINE, ST. LANDRY, TENSAS, UNION, VERNON, WEBSTER, WEST CARROLL, and WINN PARISHES

|                              | Rates    | Fringes |
|------------------------------|----------|---------|
| Power Equipment Operators    |          |         |
| Heavy Equipment Operator.... | \$ 24.90 | 7.95    |
| Light Equipment Operator.... | \$ 21.36 | 7.95    |
| Oiler.....                   | \$ 16.78 | 7.95    |
| Unit Operator.....           | \$ 17.25 | 6.95    |

POWER EQUIPMENT OPERATOR CLASSIFICATIONS:

Heavy Equipment Operator - crane, all types; derricks; deck

winches (2); hi-ho and similar type equipment; three drum or more stabilizers; pulls, all types; concrete mixer on yard and over; all pavers; ditching or trenching machines (track type); mechanics and equipment welders; well point systems; hoist, two drums or more; hoist, one drum forty vertical feet or more; scrapers; bulldozers, rubber-tired or track, other than farm-type; scoomobiles; motor patrol; gradall; rollers on hot mix; asphalt paving machines; front-end loaders other than farm-type; one cubic yard or over; shovels and backhoes, all types and equivalent equipment; piledriver; and side-boom cats.

Light Equipment Operator - single and two drum stabilizers; front-end loaders under one cubic yard; a-frame truck when handling steel or pipe; finishing machines (concrete); power subgrades; two tractors (crawler-type); one drum hoist under forty vertical feet; fireman; concrete spreader; pugmill; bituminous distributor on surface treatment and equivalent equipment; bull floats and equivalent equipment; job greaseman; unit operator; work boats not requiring licensed operators; inboard and outboard motored crew boats; concrete mixer under one yard; spray curing machines; rollers on subgrade; one air compressor over 125 cubic feet; form graders; asphalt finisher screedman; pump over four inches; scale operators; crusher; concrete jointing machines; concrete saw; tack machines and equivalent equipment; pump crete; electric elevator (inside); oiler drivers; farm-type, rubber-tired tractors with attachments except backhoes; kolum buff and similar equipment; forklifts, 10-ton capacity and under; mechanic helper; batch plant operator; oiler on crane using air to drive piles; and fireman operating steam valve.

-----  
ENGI0406-008 07/01/2010

ASCENSION, EAST BATON ROUGE, EAST FELICIANA, IBERIA, IBERVILLE, LAFAYETTE, LIVINGSTON, POINTE COUPEE, ST. HELENA, ST. MARTIN, TANGIPAOHA, VERMILION, WASHINGTON, WEST BATON ROUGE, and WEST FELICIANA PARISHES

|                              | Rates    | Fringes |
|------------------------------|----------|---------|
| Power Equipment Operators    |          |         |
| Heavy Equipment Operator.... | \$ 23.00 | 6.95    |
| Light Equipment Operator.... | \$ 20.53 | 6.95    |
| Oiler.....                   | \$ 17.36 | 6.95    |

POWER EQUIPMENT OPERATOR CLASSIFICATIONS:

Heavy Equipment Operator - crane, all types; derricks; deck winches (2); hi-ho and similar type equipment; three drum or more stabilizers; pulls, all types; concrete mixer on yard and over; all pavers; ditching or trenching machines (track type); mechanics and equipment welders; well point systems; hoist, two drums or more; hoist, one drum forty vertical feet or more; scrapers; bulldozers, rubber-tired or track, other than farm-type; scoomobiles; motor patrol; gradall; rollers on hot mix; asphalt paving machines; front-end loaders other than farm-type; one cubic yard or

over; shovels and backhoes, all types and equivalent equipment; piledriver; and side-boom cats.

Light Equipment Operator - single and two drum stabilizers; front-end loaders under one cubic yard; a-frame truck when handling steel or pipe; finishing machines (concrete); power subgrades; two tractors (crawler-type); one drum hoist under forty vertical feet; fireman; concrete spreader; pugmill; bituminous distributor on surface treatment and equivalent equipment; bull floats and equivalent equipment; job greaseman; unit operator; work boats not requiring licensed operators; inboard and outboard motored crew boats; concrete mixer under one yard; spray curing machines; rollers on subgrade; one air compressor over 125 cubic feet; form graders; asphalt finisher screedman; pump over four inches; scale operators; crusher; concrete jointing machines; concrete saw; tack machines and equivalent equipment; pump crete; electric elevator (inside); oiler drivers; farm-type, rubber-tired tractors with attachments except backhoes; kolum buff and similar equipment; forklifts, 10-ton capacity and under; mechanic helper; batch plant operator; oiler on crane using air to drive piles; and fireman operating steam valve.

-----  
ENGI0406-009 07/01/2010

ASCENSION, LAFOURCHE, PLAQUEMINES, ST. JAMES, ST. MARY, and TERREBONNE PARISHES

|                                | Rates | Fringes |
|--------------------------------|-------|---------|
| Power Equipment Operators      |       |         |
| Heavy Equipment Operator....\$ | 21.76 | 6.95    |
| Light Equipment Operator....\$ | 17.14 | 6.95    |
| Oiler.....\$                   | 13.99 | 6.95    |
| Unit Operator.....\$           | 17.25 | 6.95    |

POWER EQUIPMENT OPERATOR CLASSIFICATIONS:

Heavy Equipment Operator - crane, all types; derricks; deck winches (2); hi-ho and similar type equipment; three drum or more stabilizers; pulls, all types; concrete mixer on yard and over; all pavers; ditching or trenching machines (track type); mechanics and equipment welders; well point systems; hoist, two drums or more; hoist, one drum forty vertical feet or more; scrapers; bulldozers, rubber-tired or track, other than farm-type; scoopmobiles; motor patrol; gradall; rollers on hot mix; asphalt paving machines; front-end loaders other than farm-type; one cubic yard or over; shovels and backhoes, all types and equivalent equipment; piledriver; and side-boom cats.

Light Equipment Operator - single and two drum stabilizers; front-end loaders under one cubic yard; a-frame truck when handling steel or pipe; finishing machines (concrete); power subgrades; two tractors (crawler-type); one drum hoist under forty vertical feet; fireman; concrete spreader; pugmill; bituminous distributor on surface treatment and equivalent equipment; bull floats and

equivalent equipment; job greaseman; unit operator; work boats not requiring licensed operators; inboard and outboard motored crew boats; concrete mixer under one yard; spray curing machines; rollers on subgrade; one air compressor over 125 cubic feet; form graders; asphalt finisher screedman; pump over four inches; scale operators; crusher; concrete jointing machines; concrete saw; tack machines and equivalent equipment; pump crete; electric elevator (inside); oiler drivers; farm-type, rubber-tired tractors with attachments except backhoes; kolum buff and similar equipment; forklifts, 10-ton capacity and under; mechanic helper; batch plant operator; oiler on crane using air to drive piles; and fireman operating steam valve.

Unit Operator - minor equipment such as pumps, air compressors, welding machines, light plants, well point systems, etc.

-----  
\* IRON0058-002 06/01/2014

PLAQUEMINES PARISH, LAFOURCHE, LIVINGSTON, ST. JAMES, TANGIPAHOA, TERREBONNE, and WASHINGTON PARISHES (West of a straight line drawn from the Louisiana-Mississippi border, east of the city limits of Warrenton, Louisiana, southwest through Hammond, Louisiana to the Gulf of Mexico)

|                 | Rates    | Fringes |
|-----------------|----------|---------|
| IRONWORKER..... | \$ 20.40 | 8.07    |

-----  
IRON0623-002 10/01/2013

ASCENSION, ASSUMPTION, AVOYELLES, EAST BATON ROUGE, EAST FELICIANA, IBERIA, IBERVILLE, POINTE COUPEE, ST. HELENA, ST. MARTIN, ST. MARY, WEST BATON ROUGE, AND WEST FELICIANA PARISHES;

ACADIA, EVANGELINE, LAFAYETTE, ST. LANDRY, AND VERMILION PARISHES (East of a line drawn from the meeting point of the boundaries of the Parishes of Avoyelles, Evangeline and Rapides, southeast along the western city limits of Abbeville to the Gulf of Mexico);

CATAHOULA, CONCORDIA, AND LA SALLE PARISHES (South of a line drawn from Natchez through the city of Cottonport to the Rapides Parish line, then west along the southern border of Rapides Parish);

LAFOURCHE, TANGIPAHOA, TERREBONNE, AND WASHINGTON PARISHES (West of a straight line drawn from the Louisiana-Mississippi border, west of the city limits of Warrenton, southwest through Hammond to the Gulf of Mexico);

LIVINGSTON AND ST. JAMES PARISHES (West of a straight line drawn from the Louisiana-Mississippi border, west of the city limits of Warrenton, southwest through Hammond to the Gulf of Mexico):

|  | Rates | Fringes |
|--|-------|---------|
|--|-------|---------|

IRONWORKER.....\$ 20.61 7.47

IRON0623-008 10/01/2013

BOSSIER, CADDO, DE SOTO, RED RIVER, & WEBSTER PARISHES AND BIENVILLE, CLAIBORNE, NATCHITOCHEs, & WINN PARISHES (West of a line drawn directly south from the Arkansas-Louisiana border through the cities of Arcadia and Cloutierville); SABINE PARISH (North of a line drawn from the Natchitoches Parish boundary west through the city of Peason to the Texas-Louisiana border):

Rates Fringes

IRONWORKER.....\$ 20.61 7.47

IRON0623-011 10/01/2013

ALLEN, BEAUREGARD, CALCASIEU, CALDWELL, CAMERON, EAST CARROLL, FRANKLIN, GRANT, JACKSON, JEFFERSON DAVIS, LINCOLN, MOREHOUSE, OUACHITA, RAPIDES, RICHLAND, TENSAS, UNION, VERNON, AND WEST CARROLL PARISHES; ACADIA, EVANGELINE, LAFAYETTE, ST. LANDRY, AND VERMILION PARISHES (Southwest of Rapides Parish & west of a line south of the westernmost border between Rapides & Evangeline); BIENVILLE, CLAIBORNE, NATCHITOCHEs, AND WINN PARISHES (East of a line drawn directly south from the Arkansas-Louisiana border through the cities of Arcadia & Cloutierville); CATAHOULA, CONCORDIA, AND LA SALLE PARISHES (North of a line drawn from Natchez through the city of Cottonport to the Rapides Parish line); and MADISON PARISH (Except the cities of Mound, Delta & adjacent areas)

Rates Fringes

IRONWORKER.....\$ 20.61 7.47

IRON0623-014 10/01/2013

MADISON PARISH (Cities of Mound & Delta & Adjacent Areas)

Rates Fringes

IRONWORKER, STRUCTURAL.....\$ 20.61 7.47

LAB00207-003 07/01/2006

ALLEN, BEAUREGARD, CALCASIEU, CAMERON, JEFFERSON DAVIS, AND VERNON PARISHES

Rates Fringes

LABORER.....\$ 12.79 1.73

LAB00689-001 07/01/2006

LAFOURCHE, PLAQUEMINES, ST. JAMES, TERREBONNE, AND WASHINGTON PARISHES

Rates Fringes

LABORER

|   |          |      |
|---|----------|------|
| Lafourche and Plaquemines Parishes..... | \$ 11.19 | 1.73 |
| St. James and Washington Parishes.....  | \$ 10.00 | 1.73 |
| Terrebonne Parish.....                  | \$ 12.79 | 1.73 |

-----  
LAB00692-002 05/01/2005

BIENVILLE, BOSSIER, CADDO, CLAIBORNE, DE SOTO, RED RIVER, SABINE, AND WEBSTER PARISHES

Rates Fringes

|              |          |      |
|--------------|----------|------|
| LABORER..... | \$ 12.00 | 2.10 |
|--------------|----------|------|

-----  
LAB00762-002 01/01/2005

ACADIA, AVOYELLES, CALDWELL, CATAHOULA, CONCORDIA, EAST CARROLL, EVANGELINE, FRANKLIN, GRANT, IBERIA, JACKSON, LA SALLE, LAFAYETTE, LINCOLN, MADISON, MOREHOUSE, NATCHITOCHEs, OUACHITA, RAPIDES, RICHLAND, ST. LANDRY, ST. MARTIN, ST. MARY, TENSAS, UNION, VERMILION, WEST CARROLL, AND WINN PARISHES

Rates Fringes

|              |          |      |
|--------------|----------|------|
| LABORER..... | \$ 11.00 | 3.50 |
|--------------|----------|------|

-----  
LAB01177-002 09/01/2005

ASCENSION, EAST BATON ROUGE, EAST FELICIANA, IBERVILLE, LIVINGSTON, POINTE COUPEE, ST. HELENA, WEST BATON ROUGE and WEST FELICIANA PARISHES; ASSUMPTION PARISH (North of a line drawn from the southern limits of the town of St. James in St. James Parish to the northern limits of the town of Napoleonville in Assumption Parish and then directly west to the parish line); ST. JAMES PARISH (Excluding portion on the west bank to and including the town of Vacherie); TANGIPAHOA PARISH (South and west of a line running from the western parish line to a point directly east, which touches the northern limits of the town of Independence, then directly south to Lake Pontchartrain):

Rates Fringes

|              |          |      |
|--------------|----------|------|
| LABORER..... | \$ 15.00 | 2.77 |
|--------------|----------|------|

-----  
PAIN1244-007 04/01/2005

NEW ORLEANS AREA - ASCENSION, ASSUMPTION, CONCORDIA, EAST BATON ROUGE, EAST FELICIANA, IBERIA, IBERVILLE, LAFAYETTE, LAFOURCHE, LIVINGSTON, PLAQUEMINES, POINTE COUPEE, ST. HELENA, ST. JAMES, ST. LANDRY, ST. MARTIN, ST. MARY, TANGIPAHOA, TERREBONNE, VERMILION, WASHINGTON, WEST BATON ROUGE, AND WEST FELICIANA PARISHES



|                         | Rates    | Fringes |
|-------------------------|----------|---------|
| PAINTER.....            | \$ 15.88 | 4.32    |
| -----                   |          |         |
| PAIN1244-008 09/01/2003 |          |         |

LAKE CHARLES AREA - ACADIA, ALLEN, BEAUREGARD, CALCASIEU, CAMERON, EVANGELINE, AND JEFFERSON DAVIS PARISHES

|                         | Rates    | Fringes |
|-------------------------|----------|---------|
| PAINTER.....            | \$ 15.00 | 3.17    |
| -----                   |          |         |
| PAIN1244-009 02/01/2004 |          |         |

SHREVEPORT AREA - AVOYELLES, BIENVILLE, BOSSIER, CADDO, CALDWELL, CATAHOULA, CLAIBORNE, DE SOTO, EAST CARROLL, FRANKLIN, GRANT, JACKSON, LA SALLE, LINCOLN, MADISON, MOREHOUSE, NATCHITOCHEs, OUACHITA, RAPIDES, RED RIVER, RICHLAND, SABINE, TENSAS, UNION, VERNON, WEBSTER, WEST CARROLL, AND WINN PARISHES

|                         | Rates    | Fringes |
|-------------------------|----------|---------|
| PAINTER.....            | \$ 13.50 | 2.65    |
| -----                   |          |         |
| PLAS0487-003 04/01/2004 |          |         |

ALLEN, AVOYELLES, BEAUREGARD, BIENVILLE, BOSSIER, CADDO, CALCASIEU, CALDWELL, CAMERON, CATAHOULA, CLAIBORNE, CONCORDIA, DE SOTO, EAST CARROLL, EVANGELINE, FRANKLIN, GRANT, JACKSON, JEFFERSON DAVIS, LA SALLE, LINCOLN, MADISON, MOREHOUSE, NATCHITOCHEs, OUACHITA, RAPIDES, RED RIVER, RICHLAND, SABINE, TENSAS, UNION, VERNON, WEBSTER, WEST CARROLL, AND WINN PARISHES

|                                   | Rates    | Fringes |
|-----------------------------------|----------|---------|
| CEMENT MASON/CONCRETE FINISHER... | \$ 13.42 | 0.00    |
| -----                             |          |         |
| PLAS0812-002 06/01/2004           |          |         |

ACADIA, ASCENSION, ASSUMPTION, EAST BATON ROUGE, EAST FELICIANA, IBERIA, IBERVILLE, LAFAYETTE, LAFOURCHE, LIVINGSTON, PLAQUEMINES, POINTE COUPEE, ST. HELENA, ST. JAMES, ST. LANDRY, ST. MARTIN, ST. MARY, TANGIPAHOA, TERREBONNE, VERMILION, WASHINGTON, WEST BATON ROUGE, AND WEST FELICIANA PARISHES

|                                   | Rates    | Fringes |
|-----------------------------------|----------|---------|
| CEMENT MASON/CONCRETE FINISHER... | \$ 21.85 | 0.00    |
| -----                             |          |         |
| PLUM0060-004 06/02/2014           |          |         |

LAFOURCHE, PLAQUEMINES, ST. JAMES (Southeastern Portion), TANGIPAHOA (Cities of Robert, Hammond, Ponchatoula, Tickfaw,

Baptist & Pumpkin Center) TERREBONNE, and WASHINGTON PARISHES

|  | Rates    | Fringes |
|--|----------|---------|
| Plumber, Pipefitter,<br>Steamfitter..... | \$ 28.13 | 11.16   |
| -----                                    |          |         |
| PLUM0106-004 06/01/2014                  |          |         |

ACADIA, ALLEN, BEAUREGARD, CALCASIEU, CAMERON, IBERIA (West of Hwy 31 and Hwy 83), JEFFERSON DAVIS, LAFAYETTE, ST. LANDRY, ST. MARTIN (West of Hwy #31 and Hwy 83), and VERMILION PARISHES

|                              | Rates    | Fringes |
|------------------------------|----------|---------|
| Plumber and Steamfitter..... | \$ 25.90 | 13.65   |
| -----                        |          |         |
| * PLUM0141-002 06/01/2014    |          |         |

BIENVILLE, BOSSIER, CADDO, CLAIBORNE, DE SOTO, RED RIVER, SABINE & WEBSTER PARISHES; NATCHITOCHES, and VERNON PARISHES (Northwest of a line drawn from Natchitoches to Anacoco through Bellwood & north of Hwy #111 between Anacoco & Haddens); and WINN PARISH (West of a line drawn from Winnfield to the junction of the Parish boundaries of Winn, Bienville & Jackson)

|                              | Rates    | Fringes |
|------------------------------|----------|---------|
| Plumber and Steamfitter..... | \$ 25.25 | 11.20   |
| -----                        |          |         |
| PLUM0198-003 01/01/2014      |          |         |

ASCENSION, ASSUMPTION, EAST BATON ROUGE, EAST FELICIANA, IBERIA (East of Hwy 31 & Hwy 83), IBERVILLE, LIVINGSTON, POINTE COUPEE, ST. HELENA, ST. JAMES (Northwestern Portion), ST. MARTIN (East of Hwy 31 & Hwy 83), ST. MARY, TANGIPAHOA (Excluding Cities of Robert, Hammond, Ponchatoula, Tickfaw, Baptist & Pumpkin Center), WEST BATON ROUGE, and WEST FELICIANA PARISHES

|                              | Rates    | Fringes |
|------------------------------|----------|---------|
| Plumber and Steamfitter..... | \$ 25.54 | 10.73   |
| -----                        |          |         |
| PLUM0247-002 07/01/2014      |          |         |

AVOYELLES, CATAHOULA, CONCORDIA, GRANT, LA SALLE, NATCHITOCHES (City limits of Natchitoches, Hwy #6 to Hagedwood & Hwy #117), RAPIDES, and VERNON (Ft. Polk & Hwy #117, south to Leesville) PARISHES

|                              | Rates    | Fringes |
|------------------------------|----------|---------|
| Plumber and Steamfitter..... | \$ 25.25 | 9.40    |
| -----                        |          |         |

PLUM0659-001 07/01/2014

CALDWELL, EAST CARROLL, FRANKLIN, JACKSON, LINCOLN, MADISON, MOREHOUSE, OUACHITA, RICHLAND, TENSAS, UNION, WEST CARROLL, AND WINN (North of Hwy #84) PARISHES

|  | Rates    | Fringes |
|--|----------|---------|
| Plumber, Pipefitter,<br>Steamfitter..... | \$ 25.33 | 8.97    |

ROOF0123-002 10/01/2013

ALLEN, ASSUMPTION, BEAUREGARD, BIENVILLE, BOSSIER, CADDO, CALCASIEU, CALDWELL, CAMERON, CATAHOULA, CLAIBORNE, CONCORDIA, DE SOTO, EAST CARROLL, EVANGELINE, FRANKLIN, GRANT, JACKSON, JEFFERSON DAVIS, LAFOURCHE, LASALLE, LINCOLN, MADISON, MOREHOUSE, NATCHITOCHE, OUACHITA, PLAQUEMINES, RAPIDES, RED RIVER, RICHLAND, SABINE, ST. JAMES, ST. MARTIN (Southern Portion), ST. MARY, TENSAS, TERREBONNE, UNION, VERMILION, VERNON, WASHINGTON, WEBSTER, WEST CARROLL, AND WINN PARISHES

|             | Rates    | Fringes |
|-------------|----------|---------|
| ROOFER..... | \$ 22.59 | 6.17    |

ROOF0317-002 10/01/2011

ACADIA, ASCENSION, AVOYELLES, EAST BATON ROUGE, EAST FELICIANA, IBERIA, IBERVILLE, LAFAYETTE, LIVINGSTON, POINTE COUPEE, ST. HELENA, ST. LANDRY, ST. MARTIN (Northern Portion), TANGIPAHOA, WEST BATON ROUGE, AND WEST FELICIANA PARISHES

|             | Rates    | Fringes |
|-------------|----------|---------|
| ROOFER..... | \$ 19.12 | 6.36    |

TEAM0005-002 10/01/2003

ACADIA, ASCENSION, ASSUMPTION, EAST BATON ROUGE, EAST FELICIANA, EVANGELINE, IBERIA, IBERVILLE, LAFAYETTE, LIVINGSTON, POINTE COUPEE, ST. HELENA, ST. JAMES, ST. LANDRY, ST. MARTIN, ST. MARY, TANGIPAHOA, VERMILION, WASHINGTON, WEST BATON ROUGE, AND WEST FELICIANA PARISHES

|  | Rates | Fringes |
|--|-------|---------|
|--|-------|---------|

TRUCK DRIVER

|  |          |  |
|--|----------|--|
| 3 Tons; up to but not including 5 tons.....  | \$ 11.35 |  |
| 5 Tons & over; including but not limited to Winch, Dempsey, Dumpster, Lowboy, Semi-Trailer, Euclid, Tournapull & Similar Equipment Used for Transporting Material..... | \$ 11.52 |  |

Fuel.....\$ 11.35  
 Larger trucks to carry  
 capacity of rear axles  
 50,000 lbs. & over.....\$ 11.65  
 Over 1 ton; up to but not  
 including 3 tons.....\$ 11.23  
 Pickup.....\$ 10.98  
 Winch with "A" frame when  
 used for transporting  
 material.....\$ 11.48

-----  
TEAM0270-001 07/01/2014

LAFORCHE and PLAQUEMINES PARISHES

|                   | Rates    | Fringes |
|-------------------|----------|---------|
| TRUCK DRIVER..... | \$ 16.85 | 2.35    |

-----  
TEAM0270-002 07/01/2014

TERREBONNE PARISH

|                   | Rates    | Fringes |
|-------------------|----------|---------|
| TRUCK DRIVER..... | \$ 18.53 | 2.35    |

-----  
TEAM0568-002 11/01/2003

ALLEN, AVOYELLES, BEAUREGARD, BIENVILLE, BOSSIER, CADDO, CALCASIEU, CALDWELL, CAMERON, CATAHOULA, CLAIBORNE, CONCORDIA, DE SOTO, EAST CARROLL, FRANKLIN, GRANT, JACKSON, JEFFERSON DAVIS, LA SALLE, LINCOLN, MADISON, MOREHOUSE, NATCHITOCHEs, OUACHITA, RAPIDES, RED RIVER, RICHLAND, SABINE, TENSAS, UNION, VERNON, WEBSTER, WEST CARROLL, AND WINN PARISHES

|              | Rates    | Fringes |
|--------------|----------|---------|
| TRUCK DRIVER |          |         |
| GROUP 1..... | \$ 9.87  |         |
| GROUP 2..... | \$ 9.95  |         |
| GROUP 3..... | \$ 10.20 |         |
| GROUP 4..... | \$ 10.35 |         |
| GROUP 5..... | \$ 10.50 |         |
| GROUP 6..... | \$ 10.70 |         |
| GROUP 7..... | \$ 11.05 |         |

TRUCK DRIVER CLASSIFICATIONS:

GROUP 1 - Pickup; Spotter & Dumper of Dirt, Gravel, etc.

GROUP 2 - Stake Body; Flatbed

GROUP 3 - Single Axle Dump & Water Truck; Transit Mix, up to & including 3 yds.

GROUP 4 - Tandem Axle Dump, Batch & Water Truck over 3 tons; Pickup with Trailer

GROUP 5 - Miss. Wagon, Float, Tractor Trailer; Rubber Tired

Tractor & Wobble Wheels

GROUP 6 - Euclid; Lowboy; Dempsey Dumpster; Koehring Dump; 5 Axle Truck; Transit Mix Over 3 yds.

GROUP 7 - Forklift

-----  
WELDERS - Receive rate prescribed for craft performing operation to which welding is incidental.

=====  
Unlisted classifications needed for work not included within the scope of the classifications listed may be added after award only as provided in the labor standards contract clauses (29CFR 5.5 (a) (1) (ii)).

-----  
The body of each wage determination lists the classification and wage rates that have been found to be prevailing for the cited type(s) of construction in the area covered by the wage determination. The classifications are listed in alphabetical order of "identifiers" that indicate whether the particular rate is union or non-union.

Union Identifiers

An identifier enclosed in dotted lines beginning with characters other than "SU" denotes that the union classification and rate have found to be prevailing for that classification. Example: PLUM0198-005 07/01/2011. The first four letters , PLUM, indicate the international union and the four-digit number, 0198, that follows indicates the local union number or district council number where applicable , i.e., Plumbers Local 0198. The next number, 005 in the example, is an internal number used in processing the wage determination. The date, 07/01/2011, following these characters is the effective date of the most current negotiated rate/collective bargaining agreement which would be July 1, 2011 in the above example.

Union prevailing wage rates will be updated to reflect any changes in the collective bargaining agreements governing the rates.

0000/9999: weighted union wage rates will be published annually each January.

Non-Union Identifiers

Classifications listed under an "SU" identifier were derived from survey data by computing average rates and are not union

rates; however, the data used in computing these rates may include both union and non-union data. Example: SULA2004-007 5/13/2010. SU indicates the rates are not union majority rates, LA indicates the State of Louisiana; 2004 is the year of the survey; and 007 is an internal number used in producing the wage determination. A 1993 or later date, 5/13/2010, indicates the classifications and rates under that identifier were issued as a General Wage Determination on that date.

Survey wage rates will remain in effect and will not change until a new survey is conducted.

-----

#### WAGE DETERMINATION APPEALS PROCESS

1.) Has there been an initial decision in the matter? This can be:

- \* an existing published wage determination
- \* a survey underlying a wage determination
- \* a Wage and Hour Division letter setting forth a position on a wage determination matter
- \* a conformance (additional classification and rate) ruling

On survey related matters, initial contact, including requests for summaries of surveys, should be with the Wage and Hour Regional Office for the area in which the survey was conducted because those Regional Offices have responsibility for the Davis-Bacon survey program. If the response from this initial contact is not satisfactory, then the process described in 2.) and 3.) should be followed.

With regard to any other matter not yet ripe for the formal process described here, initial contact should be with the Branch of Construction Wage Determinations. Write to:

Branch of Construction Wage Determinations  
Wage and Hour Division  
U.S. Department of Labor  
200 Constitution Avenue, N.W.  
Washington, DC 20210

2.) If the answer to the question in 1.) is yes, then an interested party (those affected by the action) can request review and reconsideration from the Wage and Hour Administrator (See 29 CFR Part 1.8 and 29 CFR Part 7). Write to:

Wage and Hour Administrator  
U.S. Department of Labor  
200 Constitution Avenue, N.W.  
Washington, DC 20210

The request should be accompanied by a full statement of the interested party's position and by any information (wage payment data, project description, area practice material, etc.) that the requestor considers relevant to the issue.

3.) If the decision of the Administrator is not favorable, an interested party may appeal directly to the Administrative

Review Board (formerly the Wage Appeals Board). Write to:

Administrative Review Board  
U.S. Department of Labor  
200 Constitution Avenue, N.W.  
Washington, DC 20210

4.) All decisions by the Administrative Review Board are final.

=====

END OF GENERAL DECISION

STATE OF LOUISIANA  
COASTAL PROTECTION AND RESTORATION AUTHORITY

INDEX TO SHEETS

| SHEET NO. | DESCRIPTION  |
|-----------|--|
| 1         | TITLE SHEET  |
| 2         | GENERAL NOTES  |
| 3         | OVERALL SITE MAP                                     |
| 4         | SITE PLAN - LEVEE REPAIR                             |
| 5         | PROFILE AND TYPICAL CROSS-SECTION - LEVEE REPAIR     |
| 6         | CROSS-SECTIONS - LEVEE REPAIR                        |
| 7         | CROSS-SECTIONS - LEVEE REPAIR                        |
| 8         | CROSS-SECTIONS - LEVEE REPAIR                        |
| 9         | CROSS-SECTIONS - LEVEE REPAIR                        |
| 10        | CROSS-SECTIONS - LEVEE REPAIR                        |
| 11        | CROSS-SECTIONS - LEVEE REPAIR                        |
| 12        | CROSS-SECTIONS - LEVEE REPAIR                        |
| 13        | CROSS-SECTIONS - LEVEE REPAIR                        |
| 14        | CROSS-SECTIONS - LEVEE REPAIR                        |
| 15        | SITE PLAN - CHANNEL CLEANOUT                         |
| 16        | PROFILE AND TYPICAL CROSS-SECTION - CHANNEL CLEANOUT |
| 17        | CROSS SECTIONS - CHANNEL CLEANOUT                    |
| 18        | CROSS SECTIONS - CHANNEL CLEANOUT                    |
| 19        | CROSS SECTIONS - CHANNEL CLEANOUT                    |
| 20        | CROSS SECTIONS - CHANNEL CLEANOUT                    |
| 21        | CROSS SECTIONS - CHANNEL CLEANOUT                    |
| 22        | CROSS SECTIONS - CHANNEL CLEANOUT                    |
| 23        | CROSS SECTIONS - CHANNEL CLEANOUT                    |
| 24        | CROSS SECTIONS - CHANNEL CLEANOUT                    |
| 25        | SITE PLAN - STRUCTURE MAINTENANCE                    |

HWY. 384 HYDROLOGIC RESTORATION PROJECT  
MAINTENANCE EVENT  
CS-21  
CAMERON PARISH

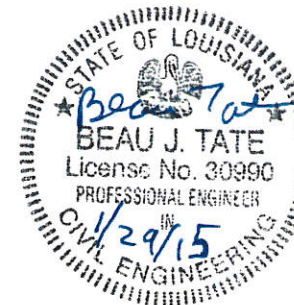
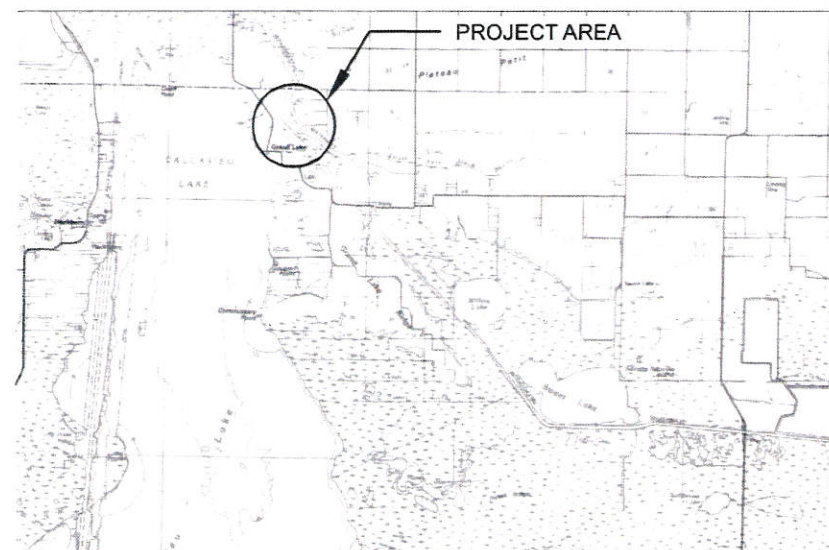
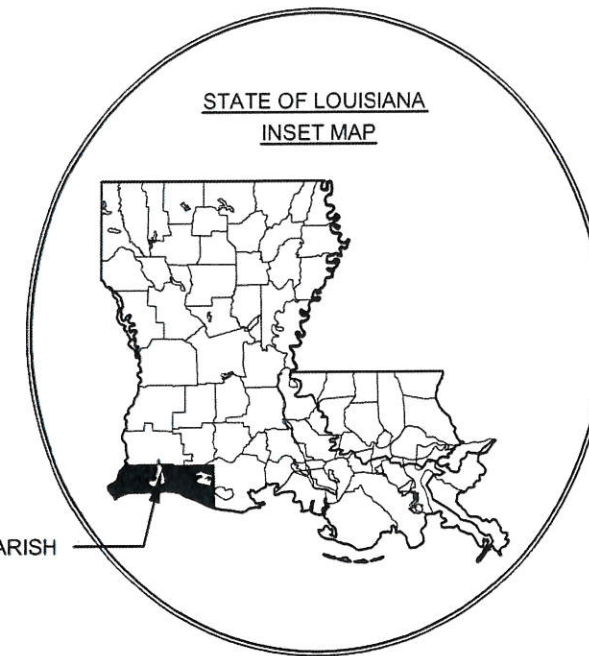

*[Signature]*

CHIEF, OPERATIONS DIVISION

*[Signature]*

REGIONAL MANAGER, OPERATIONS DIVISION

*[Signature]*

PROJECT ENGINEER, OPERATIONS DIVISION



LICENSURE CLASSIFICATION REQUIREMENTS  
HEAVY CONSTRUCTION

| REV. | DATE | DESCRIPTION | BY |
|------|------|-------------|----|
|      |      |             |    |
|      |      |             |    |
|      |      |             |    |
|      |      |             |    |

**ROYAL ENGINEERS & CONSULTANTS, LLC**  
1231 CAMELLIA BOULEVARD  
Lafayette, LOUISIANA 70508

**COASTAL PROTECTION AND RESTORATION AUTHORITY**  
450 LAUREL STREET  
BATON ROUGE, LOUISIANA 70801

HWY. 384 HYDROLOGIC RESTORATION PROJECT (CS-21) MAINTENANCE EVENT

TITLE SHEET

STATE PROJECT NUMBER: CS-21

FEDERAL PROJECT NUMBER: CS-21

DATE: NOVEMBER 2014

DRAWN BY: TH

DESIGNED BY: BT

APPROVED BY: BT

SHEET 1 OF 25



GENERAL NOTES:

1. ALL ELEVATIONS ARE GIVEN IN THE NORTH AMERICAN VERTICAL DATUM OF 1988 (NAVD88) GEOID 12A U.S. SURVEY FEET. ALL HORIZONTAL COORDINATES ARE GIVEN IN THE NORTH AMERICAN DATUM OF 1983 (NAD83) LOUISIANA STATE PLANE SOUTH ZONE U.S. FEET.
2. THE CONTRACTOR SHALL CALL LOUISIANA ONE CALL AT 1-800-272-3020 A MINIMUM OF 5 WORKING DAYS PRIOR TO THE CONSTRUCTION TO LOCATE EXISTING UTILITIES AT THE PROJECT SITE. THE CONTRACTOR SHALL CONTACT AND COORDINATE WITH PIPELINE COMPANIES WHO HAVE PIPELINES IN THE AREA TO GET PIPELINES MARKED. A MAGNETOMETER SURVEY SHALL BE DONE BY THE CONTRACTOR PRIOR TO ANY DREDGING TAKING PLACE.
3. CONTRACTOR SHALL IDENTIFY AND MARK THE CONSTRUCTION AREA ACCORDING TO THE LINES AND GRADES AS SET FORTH IN THE PLANS. ONLY AFTER FINAL ACCEPTANCE OF THE WORK PERFORMED SHALL THE CONTRACTOR REMOVE THE MARKERS.
4. CONTRACTOR MUST STAY WITHIN FOOT PRINT OF PROPOSED LEVEE. NO EQUIPMENT OR EARTHEN MATERIAL WILL BE ALLOWED ON EXISTING MARSH AT ANY TIME.
5. FILL SHOULD BE PLACED IN 10 TO 12 INCH LOOSE LIFTS. MAXIMUM COMPACTION CRITERIA FOR DRY DENSITY AT LEAST EQUAL TO 90% OF ITS MAXIMUM, AS DETERMINED BY THE STANDARD PROCTOR COMPACTION TEST, ASTM D698, SHOULD BE USED.
6. IMPORTED FILL MATERIAL MUST BE AN ACCEPTED LEVEE CLAY MATERIAL FURNISHED FROM AN EXISTING BORROW SITE. CONTRACTOR IS REQUIRED TO SUBMIT CERTIFICATION OF TESTING OF ANY FILL MATERIAL TO BE USED.
7. ALL COMPLETED LEVEE SECTIONS MUST BE GRADED/SLOPED BY MECHANICAL MEANS.
8. THE CONTRACTOR IS RESPONSIBLE FOR ALL SURVEYS TO BE PERFORMED FOR ACCEPTANCE. ALL SURVEYS MUST BE CERTIFIED BY A PROFESSIONAL LAND SURVEYOR LICENSED BY THE STATE OF LOUISIANA. HORIZONTAL MEASUREMENTS SHALL BE REFERENCED TO STATE PLANE COORDINATES. ELEVATION MEASUREMENTS SHALL BE REFERENCED TO NAVD88.
9. THE CONTRACTOR IS RESPONSIBLE FOR NOTIFYING THE LANDOWNERS PRIOR TO ENTERING THE PROJECT SITE FROM OLD DUMP ROAD. ALTERNATE ACCESS ROUTES ARE TO BE APPROVED BY THE ENGINEER PRIOR TO START OF CONSTRUCTION. LANDOWNER CONTACT INFORMATION IS SHOWN BELOW.

| CONTACT NAME   | PHONE NUMBER  | ALTERNATE PHONE NUMBER |
|----------------|---------------|------------------------|
| MARK LANNIN    | (337)474-1699 | (337)532-6245          |
| BUCK STEVENSON | (337)598-1214 | (337)661-7111          |

| BID SUMMARY |                           |             |       |
|-------------|---------------------------|-------------|-------|
| ITEM NO.    | DESCRIPTION               | UNIT        | QTY   |
| 1           | MOB AND DEMOB             | LUMP SUM    | 1     |
| 2           | STRUCTURE MAINTENANCE     | LUMP SUM    | 1     |
| 3           | LEVEE REPAIR              | LINEAR FOOT | 1,174 |
| 4           | DREDGING OF INLET CHANNEL | LINEAR FOOT | 1,132 |
| 5           | CONSTRUCTION SURVEY       | LUMP SUM    | 1     |

BENCHMARK INFORMATION

STATION NAME: CS21-SM-01  
 STAMPING: "384 N"  
 NAD83 (2011) EPOCH 2010 GEODETIC POSTION:  
 LATITUDE: 30° 02' 34.92835"  
 LONGITUDE: 93° 16' 16.77063"  
 NAD83 (2011) EPOCH 2010 LSZ (1702) FT:  
 NORTHING: 566,327.88'  
 EASTING: 2,667,690.99'  
 ADJUSTED NAVD88 ELEVATION:  
 2.12 FT  
 ELLIPSOID HEIGHT= -26.432 M  
 GEOID12A HEIGHT= -27.197 M

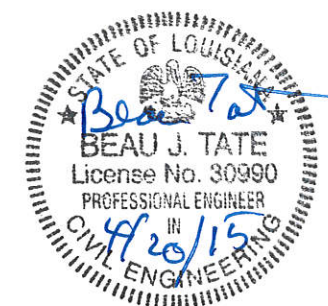

|      |      |             |    |  |  |   |                     |
|------|------|-------------|----|--|--|---|---------------------|
|      |      |             |    |  <p>ROYAL ENGINEERS<br/>&amp; CONSULTANTS, LLC<br/>1231 CAMELLIA BOULEVARD<br/>Lafayette, LOUISIANA 70508</p> | <p>COASTAL PROTECTION AND RESTORATION AUTHORITY<br/>450 LAUREL STREET<br/>BATON ROUGE, LOUISIANA 70801</p> | HWY. 384 HYDROLOGIC RESTORATION PROJECT (CS-21) MAINTENANCE EVENT | GENERAL NOTES       |
| REV. | DATE | DESCRIPTION | BY |  |  | DRAWN BY: TH  |                     |
|      |      |             |    |  |  | STATE PROJECT NUMBER: CS-21                                       | DATE: NOVEMBER 2014 |
|      |      |             |    |  |  | FEDERAL PROJECT NUMBER: CS-21                                     | SHEET 2 OF 25       |

LOUISIANA COORDINATE SYSTEM  
SOUTH ZONE  
NAD83



INTRACOASTAL  
WATERWAY

STATION 11+74  
END LEVEE REPAIR  
N:564923.07  
E:2669947.47

STATION 0+00  
BEGIN CHANNEL CLEAN OUT  
N:563903.28  
E:2672011.74

LEVEE ALIGNMENT/CENTERLINE

STATION 0+00  
BEGIN LEVEE REPAIR  
N:563996.10  
E:2670664.57

STATION 11+32  
END CHANNEL CLEAN OUT  
N:563492.4593'  
E:2671097.3617'

CHANNEL CENTERLINE/ALIGNMENT

PL ——— EXISTING PIPELINE  
- - - - - WORK LIMITS

NOTES:

1. DREDGE APPROX. 1,132 FT OF INLET CHANNEL. SIDECAST EXCAVATED MATERIAL.
2. REPAIR APPROX. 1,174 FT OF LEVEE.
3. FLUSH (3) CULVERTS OF ALL DEBRIS.
4. REPAIR WALKWAY AND FENCE.
5. CONTRACTOR MUST KEEP ALL EQUIPMENT WITHIN THE WORK LIMITS AS SHOWN ON THE PLANS. LAND-BASED EQUIPMENT WILL BE PERMITTED FOR WORK REQUIRED FOR THE LEVEE REPAIR. NO LAND-BASED EQUIPMENT WILL BE ALLOWED FOR DREDGING OF THE INLET CHANNEL.

STRUCTURE NO. 1  
EXISTING CULVERTS

EXISTING TRASH RACK  
& WALKWAY



| REV. | DATE | DESCRIPTION | BY |
|------|------|-------------|----|
|      |      |             |    |
|      |      |             |    |
|      |      |             |    |

**ROYAL ENGINEERS  
& CONSULTANTS, LLC**  
1231 CAMELLIA BOULEVARD  
Lafayette, LOUISIANA 70508

**COASTAL PROTECTION AND  
RESTORATION AUTHORITY**  
450 LAUREL STREET  
BATON ROUGE, LOUISIANA 70801

DRAWN BY: TH      DESIGNED BY: BT

HWY. 384 HYDROLOGIC RESTORATION  
PROJECT (CS-21) MAINTENANCE EVENT

STATE PROJECT NUMBER: CS-21  
FEDERAL PROJECT NUMBER: CS-21  
APPROVED BY: BT

OVERALL SITE MAP

DATE: NOVEMBER 2014  
SHEET 3 OF 25

LOUISIANA STATE COORDINATE SYSTEM  
SOUTH ZONE NAD83



STATION 11+74  
END LEVEE REPAIR  
N:564923.07  
E:2669947.47

STATION 0+00  
BEGIN LEVEE REPAIR  
N:563996.10  
E:2670664.57



NOTES:

1. THE CONTRACTOR IS RESPONSIBLE FOR NOTIFYING THE LANDOWNERS PRIOR TO ENTERING THE PROJECT SITE FROM OLD DUMP ROAD. ALTERNATE ACCESS ROUTES ARE TO BE APPROVED BY THE ENGINEER PRIOR TO START OF CONSTRUCTION.
2. FILL MATERIAL SHALL BE PLACED IN 10 TO 12 INCH LOOSE LIFTS. FILL MATERIAL SHALL BE COMPACTED AFTER PLACEMENT OF EACH LIFT, AND SHALL BE COMPACTED TO 90% MAXIMUM DRY DENSITY, AS DETERMINED BY THE STANDARD PROCTOR TEST (ASTM D698). THE CONTRACTOR WILL BE RESPONSIBLE FOR PERFORMING COMPACTION TESTING ON THE FILL MATERIAL. THE CONTRACTOR IS REQUIRED TO PROVIDE THE RESULTS OF TESTING TO THE ENGINEER FOR REVIEW AND ACCEPTANCE.
3. THE CONTRACTOR WILL BE PERMITTED TO USE LAND-BASED EQUIPMENT FOR THE LEVEE REPAIR. THE CONTRACTOR SHALL NOT OPERATE ANY LAND BASED EQUIPMENT OUTSIDE OF THE WORK LIMITS AS SHOWN ON SHEET 3.

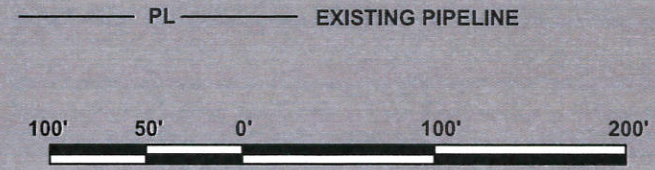

| REV. | DATE | DESCRIPTION | BY |
|------|------|-------------|----|
|      |      |             |    |
|      |      |             |    |
|      |      |             |    |



**ROYAL ENGINEERS  
& CONSULTANTS, LLC**  
1231 CAMELLIA BOULEVARD  
Lafayette, LOUISIANA 70508

**COASTAL PROTECTION AND  
RESTORATION AUTHORITY**

450 LAUREL STREET  
BATON ROUGE, LOUISIANA 70801

DRAWN BY: TH      DESIGNED BY: BT

**HWY. 384 HYDROLOGIC RESTORATION  
PROJECT (CS-21) MAINTENANCE EVENT**

STATE PROJECT NUMBER: CS-21

FEDERAL PROJECT NUMBER: CS-21

APPROVED BY: BT

**SITE PLAN  
LEVEE REPAIR**

DATE: NOVEMBER 2014

SHEET 4 OF 25

Elevation (FT) NAVD 88

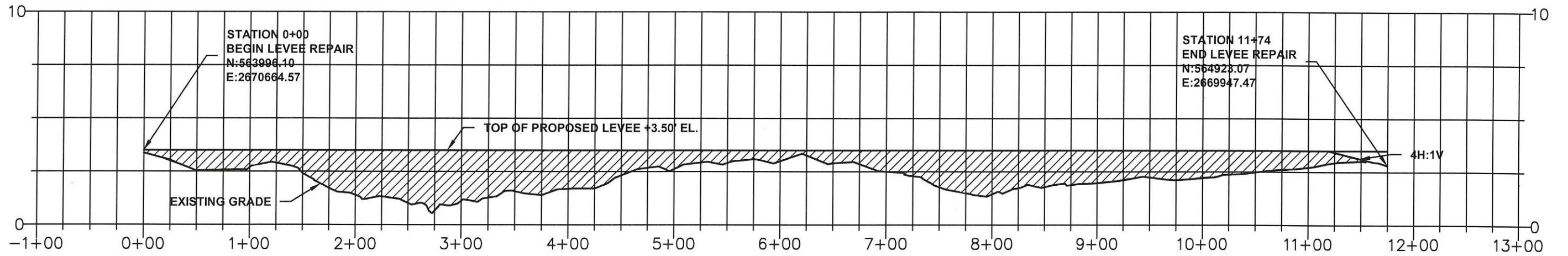

**LEVEE REPAIR PROFILE**  
 HORIZONTAL SCALE: 1"=100', VERTICAL SCALE 1"=5'

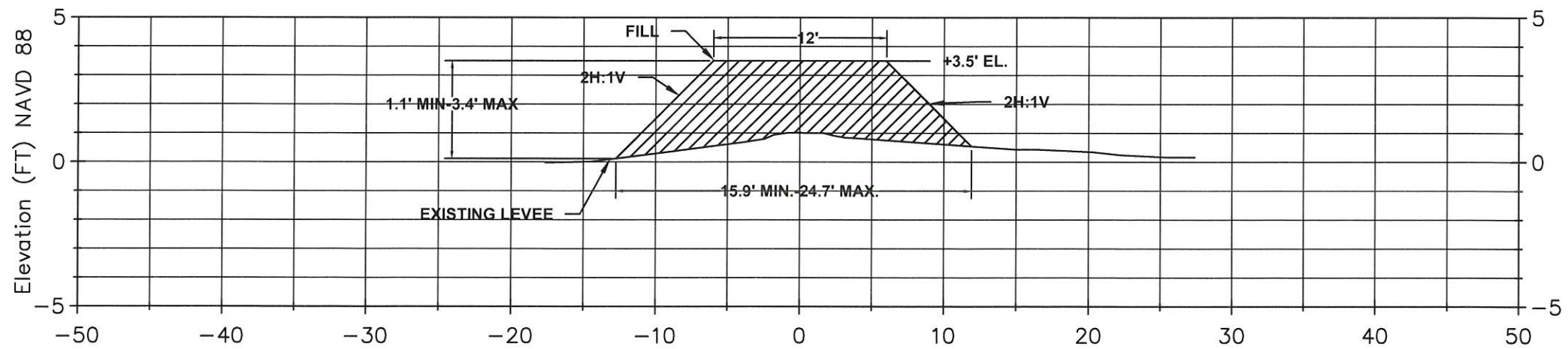

**TYPICAL CROSS-SECTION**  
 HORIZONTAL SCALE: 1"=100', VERTICAL SCALE 1"=5'



| REV. | DATE | DESCRIPTION | BY |
|------|------|-------------|----|
|      |      |             |    |
|      |      |             |    |
|      |      |             |    |



**ROYAL ENGINEERS  
 & CONSULTANTS, LLC**  
 1231 CAMELLIA BOULEVARD  
 Lafayette, LOUISIANA 70508

**COASTAL PROTECTION AND  
 RESTORATION AUTHORITY**

450 LAUREL STREET  
 BATON ROUGE, LOUISIANA 70801

DRAWN BY: TH

DESIGNED BY: BT

HWY. 384 HYDROLOGIC RESTORATION  
 PROJECT (CS-21) MAINTENANCE EVENT

STATE PROJECT NUMBER: CS-21

FEDERAL PROJECT NUMBER: CS-21

APPROVED BY: BT

PROFILE AND TYPICAL  
 SECTION - LEVEE REPAIR

DATE: NOVEMBER 2014

SHEET 5 OF 25

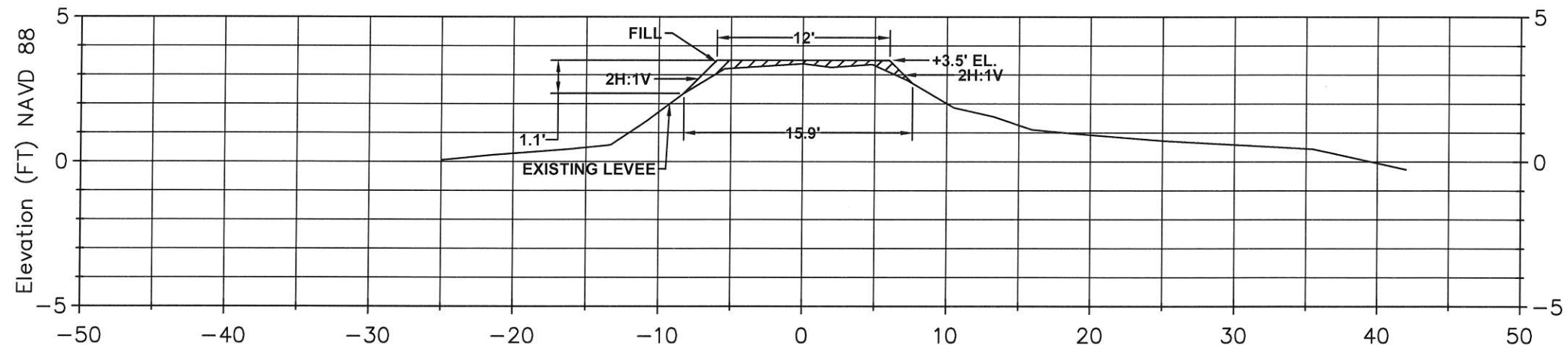

STATION 0+00.00  
HORIZONTAL SCALE: 1"=10', VERTICAL SCALE: 1"=5'

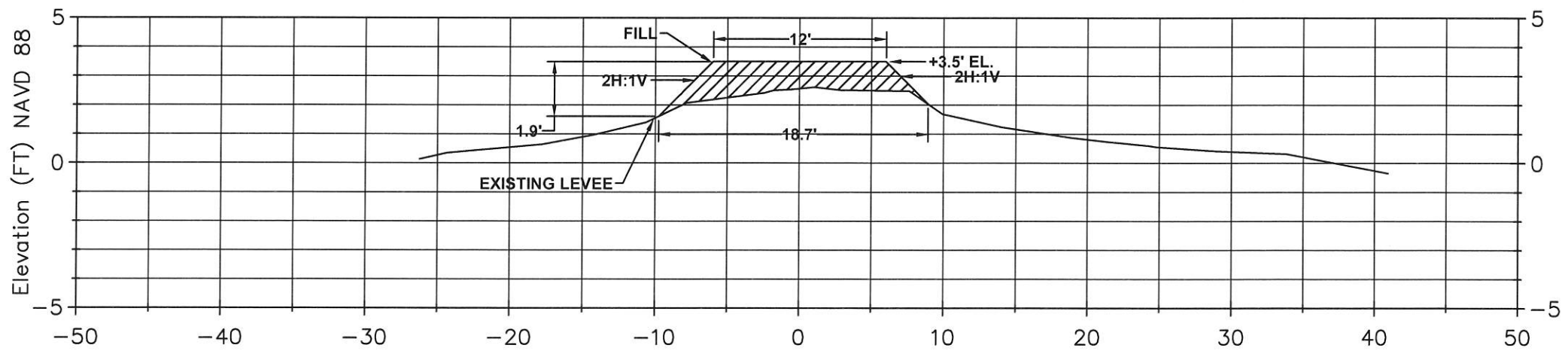

STATION 0+50.00  
HORIZONTAL SCALE: 1"=10', VERTICAL SCALE: 1"=5'

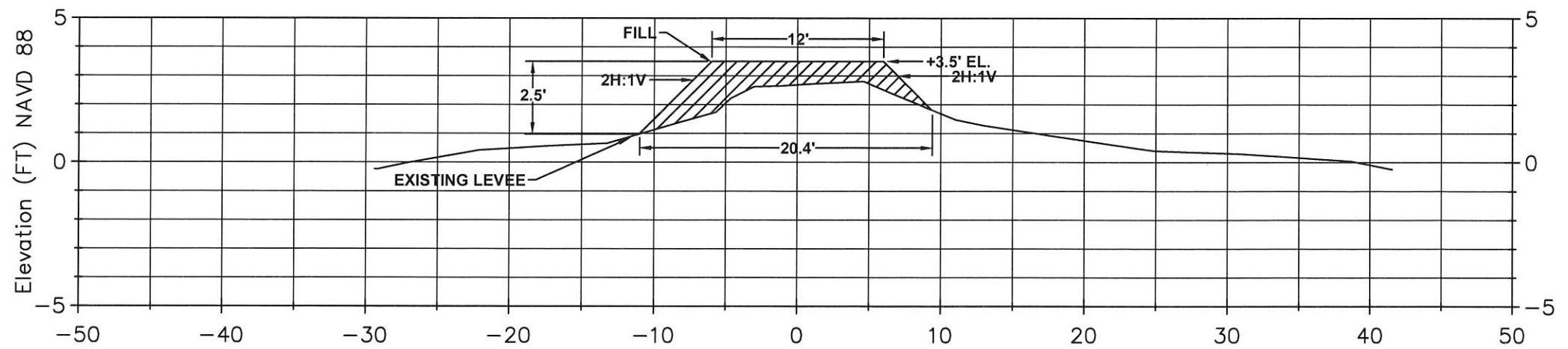

STATION 1+00.00  
HORIZONTAL SCALE: 1"=10', VERTICAL SCALE: 1"=5'

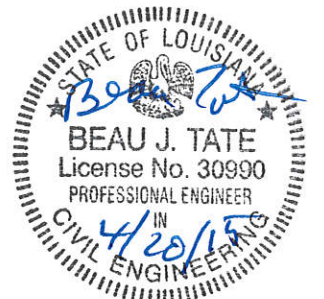

| REV. | DATE | DESCRIPTION | BY |
|------|------|-------------|----|
|      |      |             |    |
|      |      |             |    |
|      |      |             |    |
|      |      |             |    |



**ROYAL ENGINEERS  
& CONSULTANTS, LLC**  
1231 CAMELLIA BOULEVARD  
Lafayette, LOUISIANA 70508

**COASTAL PROTECTION AND  
RESTORATION AUTHORITY**

450 LAUREL STREET  
BATON ROUGE, LOUISIANA 70801

DRAWN BY: TH

DESIGNED BY: BT

HWY. 384 HYDROLOGIC RESTORATION  
PROJECT (CS-21) MAINTENANCE EVENT

STATE PROJECT NUMBER: CS-21

FEDERAL PROJECT NUMBER: CS-21

APPROVED BY: BT

CROSS SECTIONS  
LEVEE REPAIR

DATE: NOVEMBER 2014

SHEET 6 OF 25

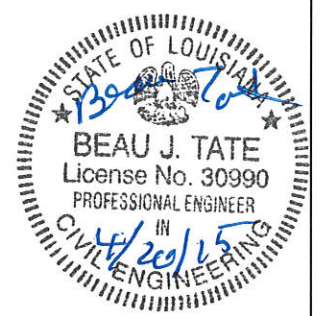
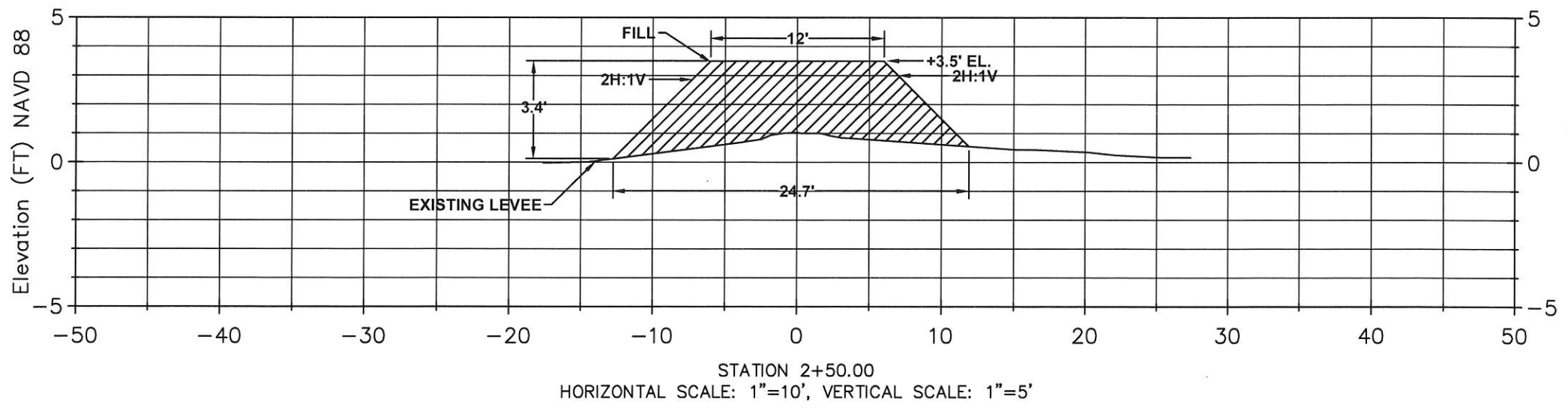
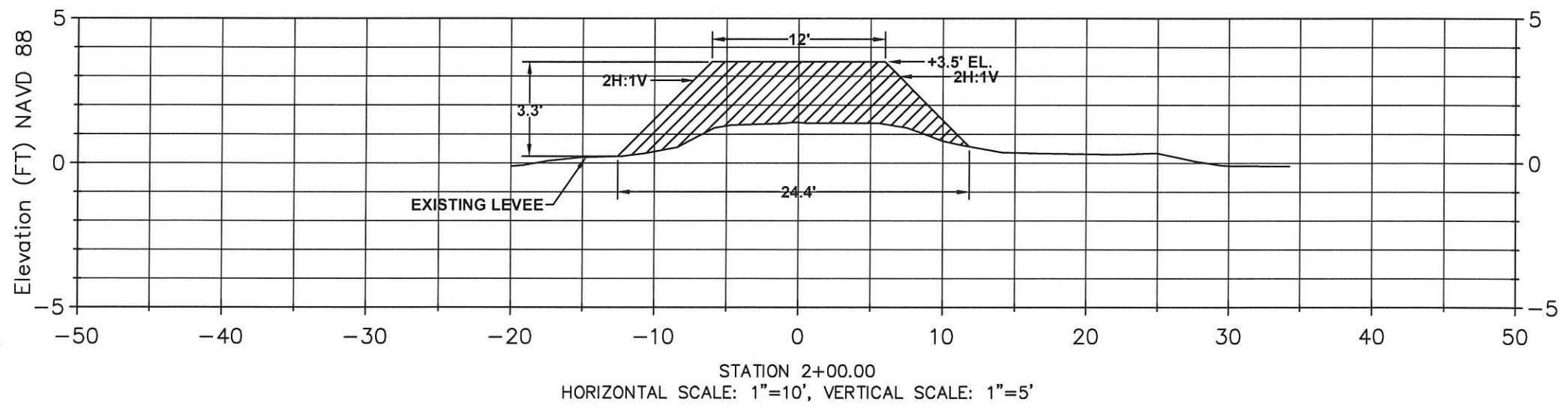
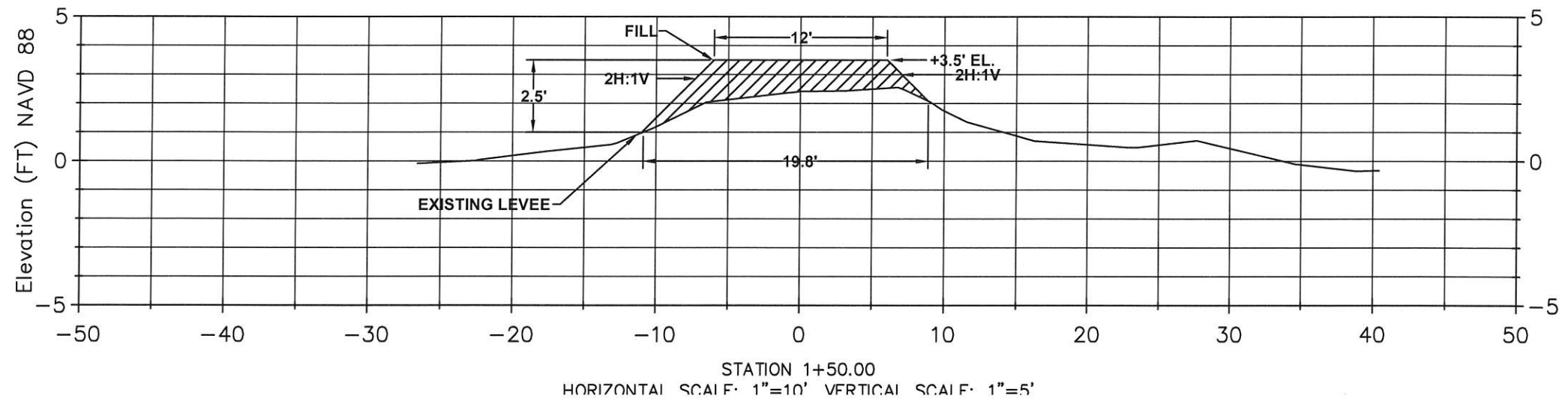

| REV | DATE | DESCRIPTION | BY |
|-----|------|-------------|----|
|     |      |             |    |
|     |      |             |    |
|     |      |             |    |
|     |      |             |    |

**ROYAL ENGINEERS & CONSULTANTS, LLC**  
 1231 CAMELLIA BOULEVARD  
 Lafayette, LOUISIANA 70508

**COASTAL PROTECTION AND RESTORATION AUTHORITY**  
 450 LAUREL STREET  
 BATON ROUGE, LOUISIANA 70801

DRAWN BY: TH      DESIGNED BY: BT

**HWY. 384 HYDROLOGIC RESTORATION PROJECT (CS-21) MAINTENANCE EVENT**

STATE PROJECT NUMBER: CS-21  
 FEDERAL PROJECT NUMBER: CS-21  
 APPROVED BY: BT

**CROSS SECTIONS**  
**LEVEE REPAIR**

DATE: NOVEMBER 2014  
 SHEET 7 OF 25

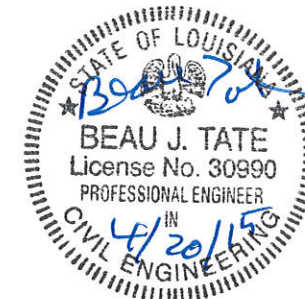
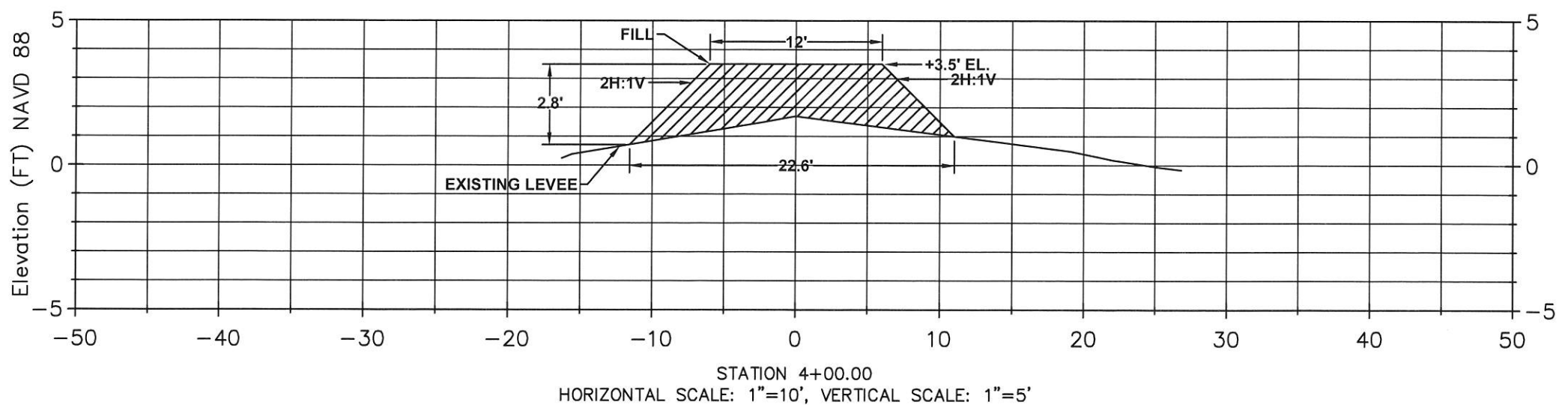
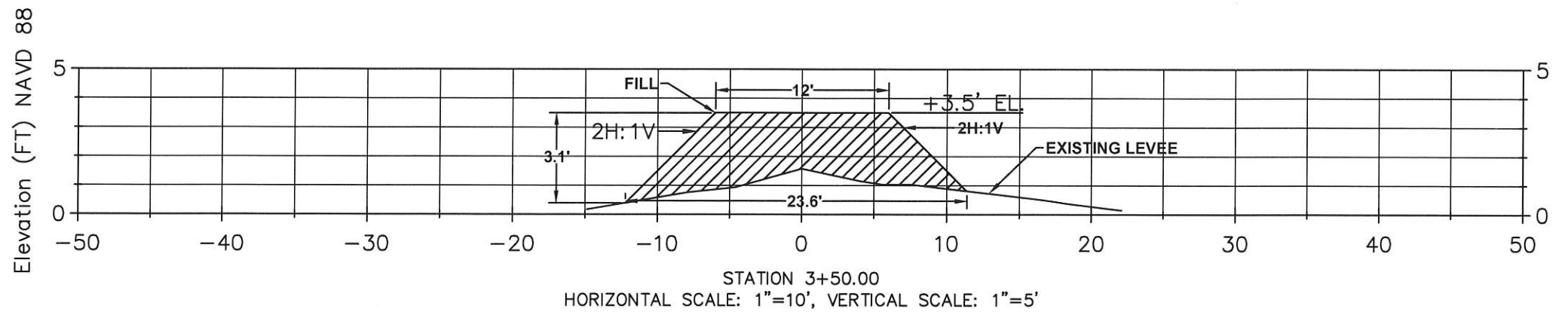
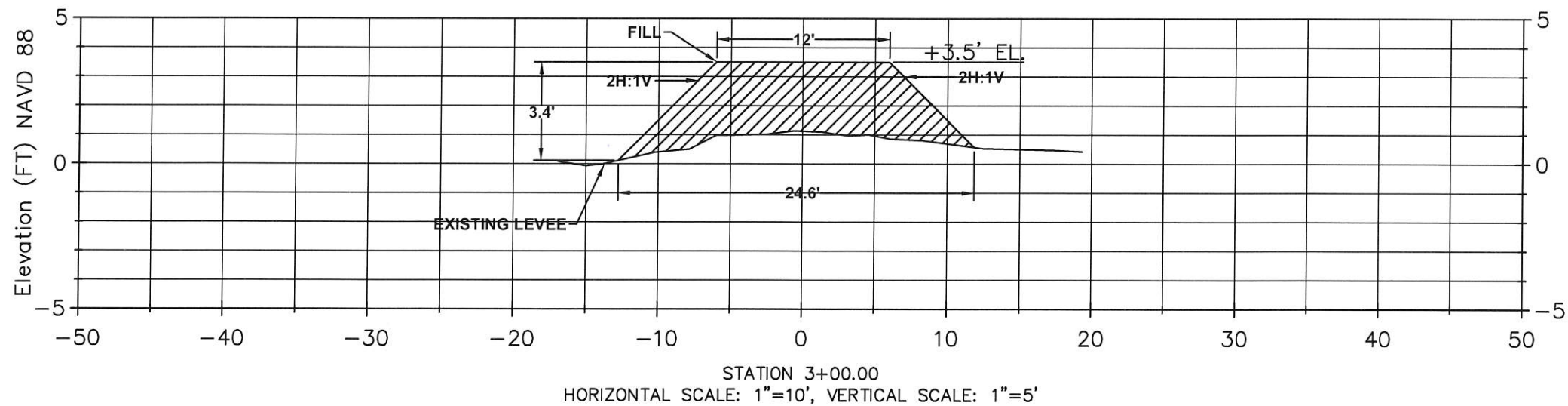

| REV. | DATE | DESCRIPTION | BY |
|------|------|-------------|----|
|      |      |             |    |
|      |      |             |    |
|      |      |             |    |



**ROYAL ENGINEERS  
& CONSULTANTS, LLC**  
1231 CAMELLIA BOULEVARD  
Lafayette, LOUISIANA 70508

**COASTAL PROTECTION AND  
RESTORATION AUTHORITY**

450 LAUREL STREET  
BATON ROUGE, LOUISIANA 70801

DRAWN BY: TH

DESIGNED BY: BT

HWY. 384 HYDROLOGIC RESTORATION  
PROJECT (CS-21) MAINTENANCE EVENT

STATE PROJECT NUMBER: CS-21

FEDERAL PROJECT NUMBER: CS-21

APPROVED BY: BT

CROSS SECTIONS  
LEVEE REPAIR

DATE: NOVEMBER 2014

SHEET 8 OF 25

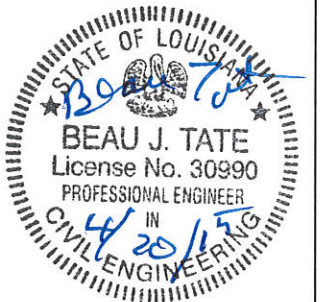
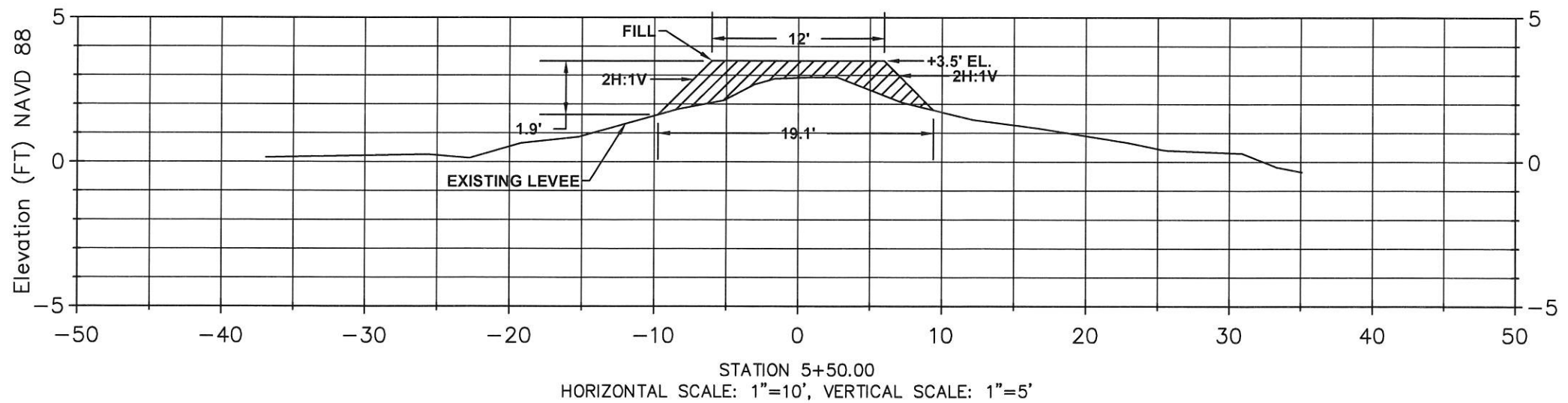
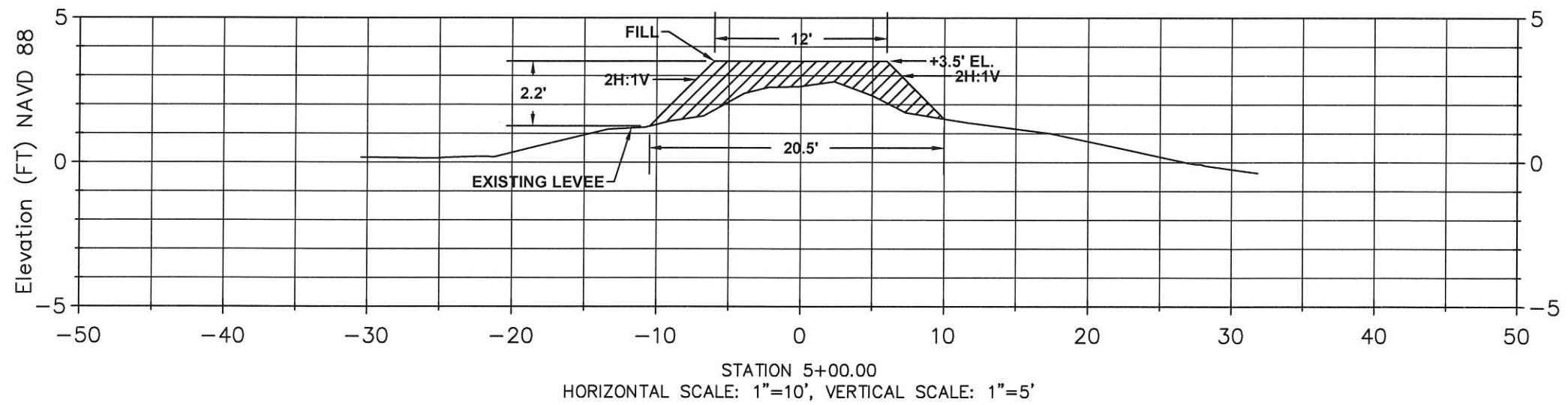
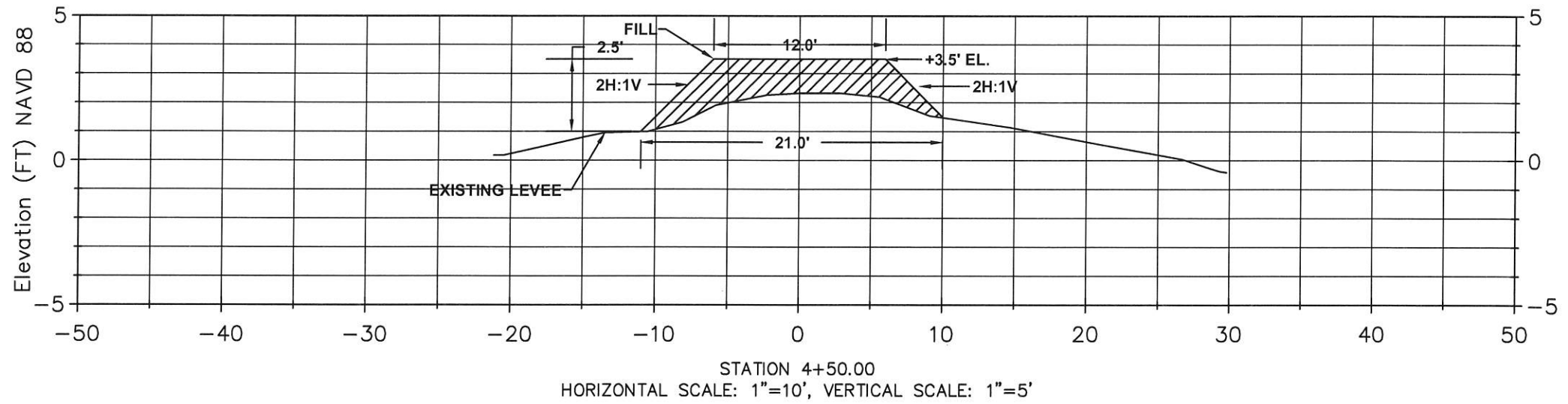

| REV. | DATE | DESCRIPTION | BY |
|------|------|-------------|----|
|      |      |             |    |
|      |      |             |    |
|      |      |             |    |



**ROYAL ENGINEERS  
& CONSULTANTS, LLC**  
1231 CAMELLIA BOULEVARD  
Lafayette, LOUISIANA 70508

**COASTAL PROTECTION AND RESTORATION AUTHORITY**  
450 LAUREL STREET  
BATON ROUGE, LOUISIANA 70801

DRAWN BY: TH      DESIGNED BY: BT

HWY. 384 HYDROLOGIC RESTORATION PROJECT (CS-21) MAINTENANCE EVENT

STATE PROJECT NUMBER: CS-21  
FEDERAL PROJECT NUMBER: CS-21  
APPROVED BY: BT

CROSS SECTIONS  
LEVEE REPAIR

DATE: NOVEMBER 2014  
SHEET 9 OF 25



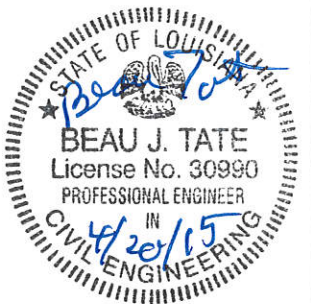
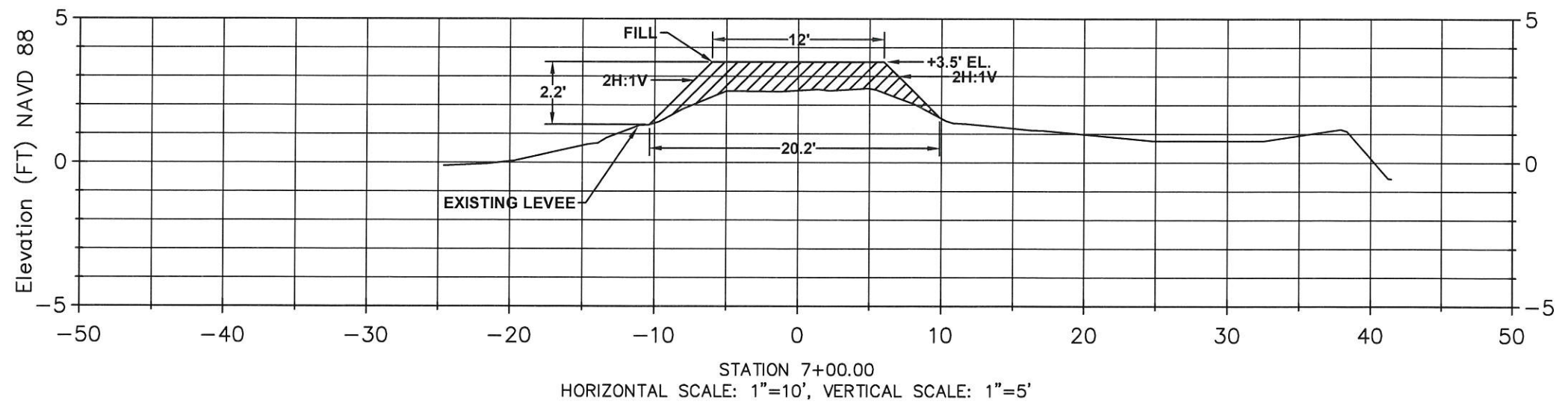
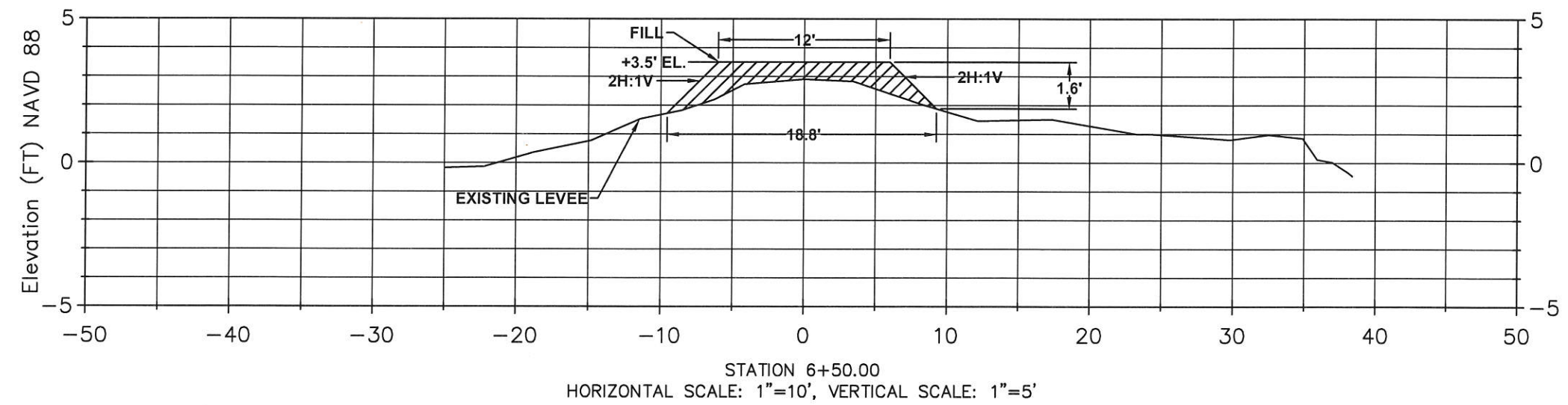
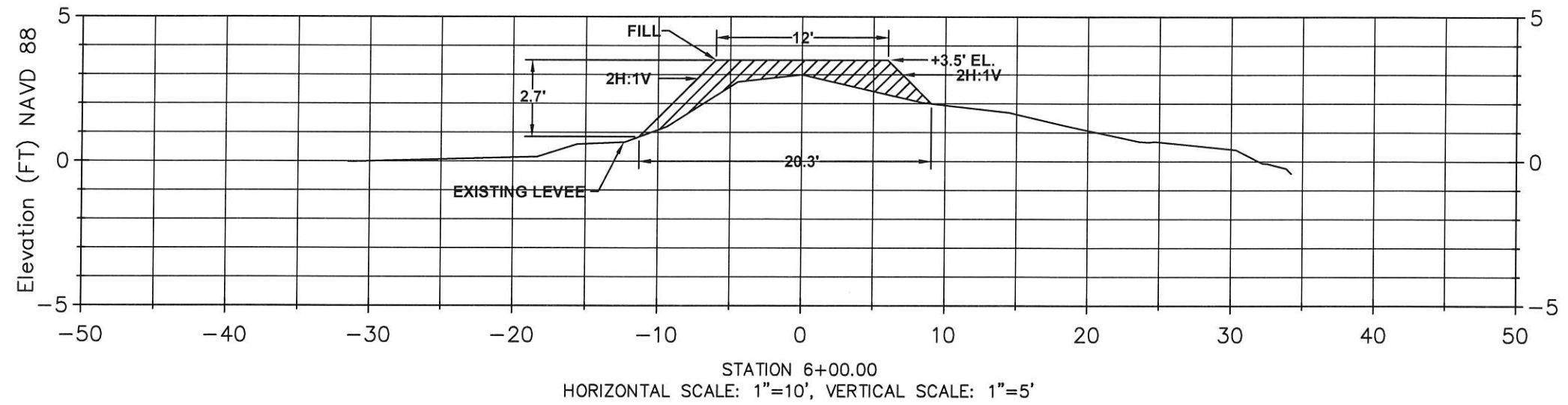

| REV. | DATE | DESCRIPTION | BY |
|------|------|-------------|----|
|      |      |             |    |
|      |      |             |    |
|      |      |             |    |
|      |      |             |    |



ROYAL ENGINEERS  
& CONSULTANTS, LLC  
1231 CAMELLIA BOULEVARD  
Lafayette, LOUISIANA 70508

COASTAL PROTECTION AND  
RESTORATION AUTHORITY

450 LAUREL STREET  
BATON ROUGE, LOUISIANA 70801

DRAWN BY: TH

DESIGNED BY: BT

HWY. 384 HYDROLOGIC RESTORATION  
PROJECT (CS-21) MAINTENANCE EVENT

STATE PROJECT NUMBER: CS-21

FEDERAL PROJECT NUMBER: CS-21

APPROVED BY: BT

CROSS SECTIONS  
LEVEE REPAIR

DATE: NOVEMBER 2014

SHEET 10 OF 25

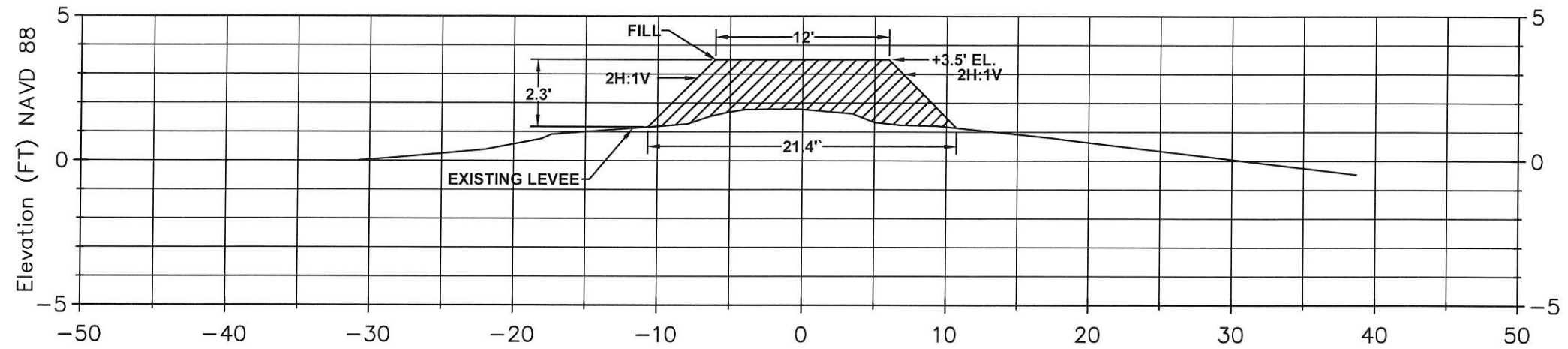

STATION 7+50.00  
HORIZONTAL SCALE: 1"=10', VERTICAL SCALE: 1"=5'

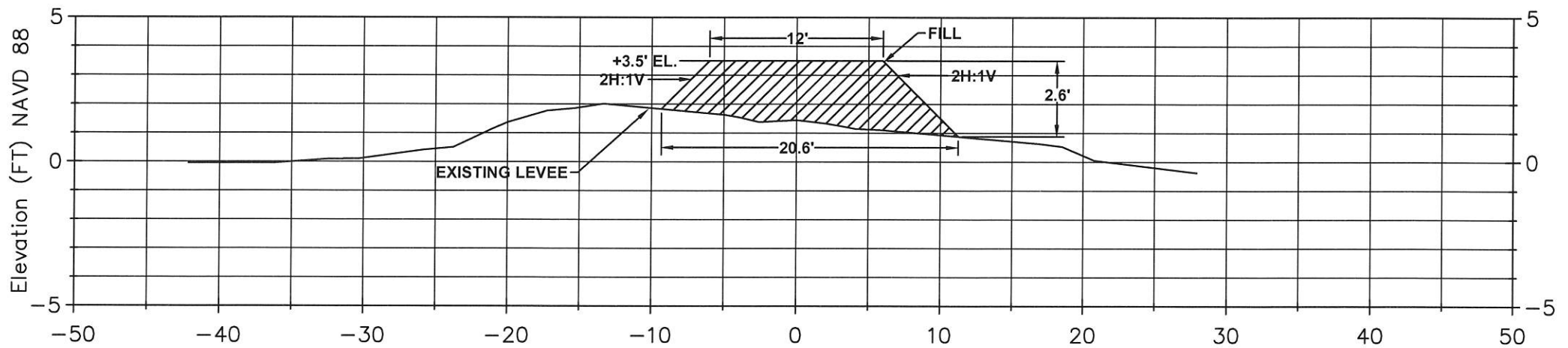

STATION 8+00.00  
HORIZONTAL SCALE: 1"=10', VERTICAL SCALE: 1"=5'

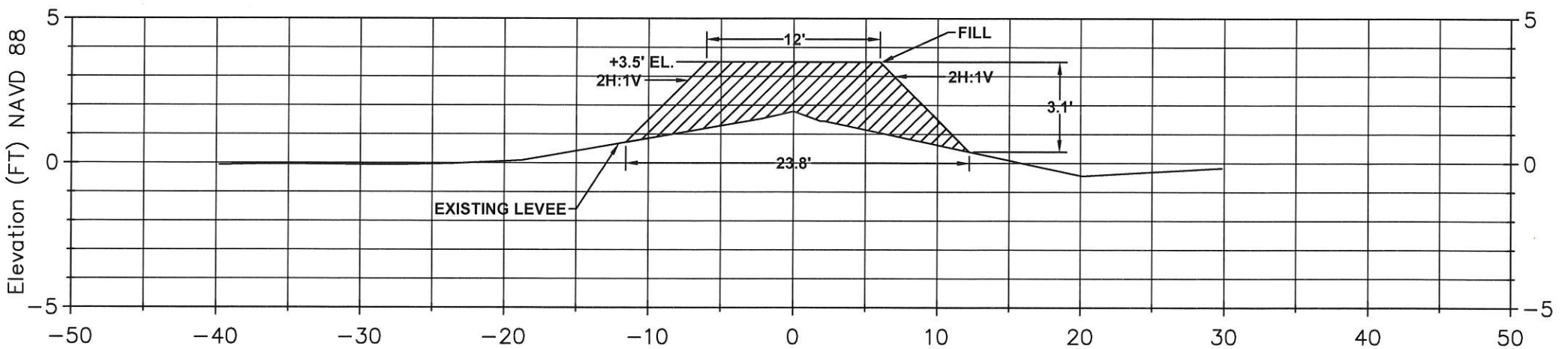

STATION 8+50.00  
HORIZONTAL SCALE: 1"=10', VERTICAL SCALE: 1"=5'

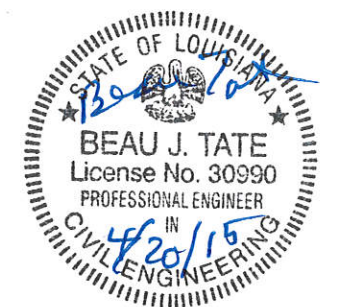

| REV. | DATE | DESCRIPTION | BY |
|------|------|-------------|----|
|      |      |             |    |
|      |      |             |    |
|      |      |             |    |

**ROYAL ENGINEERS & CONSULTANTS, LLC**  
1231 CAMELLIA BOULEVARD  
Lafayette, LOUISIANA 70508

**COASTAL PROTECTION AND RESTORATION AUTHORITY**  
450 LAUREL STREET  
BATON ROUGE, LOUISIANA 70801

HWY. 384 HYDROLOGIC RESTORATION PROJECT (CS-21) MAINTENANCE EVENT

CROSS SECTIONS  
LEVEE REPAIR

DRAWN BY: TH

DESIGNED BY: BT

APPROVED BY: BT

DATE: NOVEMBER 2014

SHEET 11 OF 25

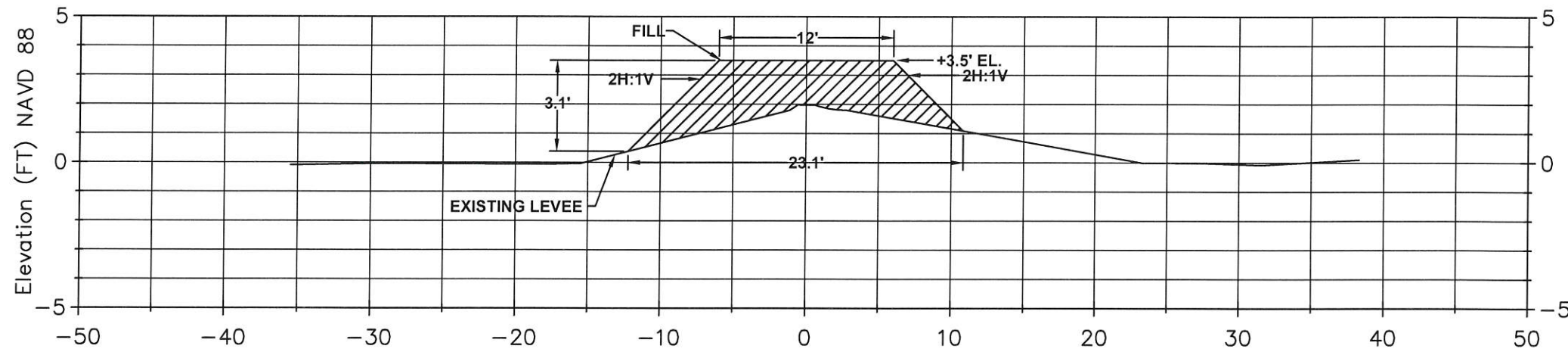

STATION 9+00.00  
HORIZONTAL SCALE: 1"=10', VERTICAL SCALE: 1"=5'

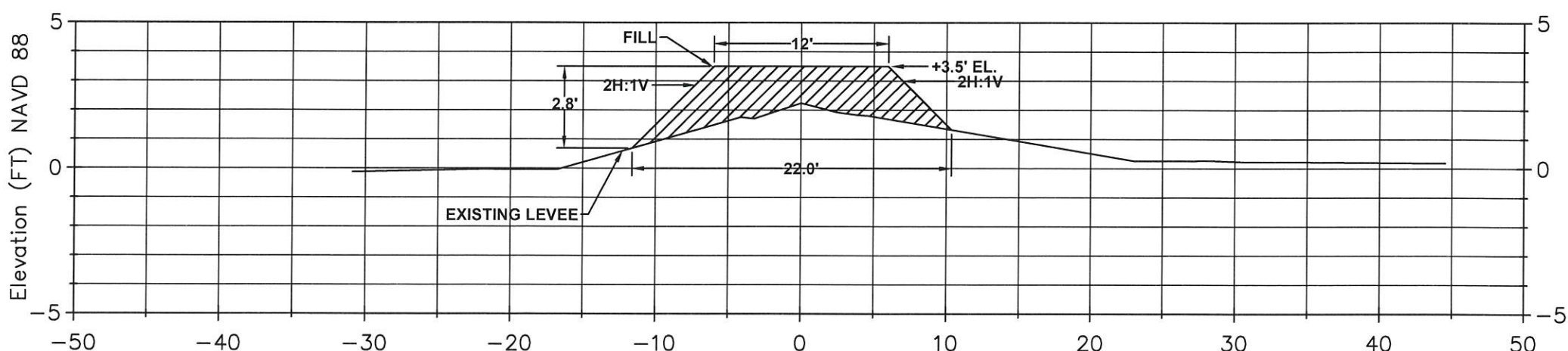

STATION 9+50.00  
HORIZONTAL SCALE: 1"=10', VERTICAL SCALE: 1"=5'

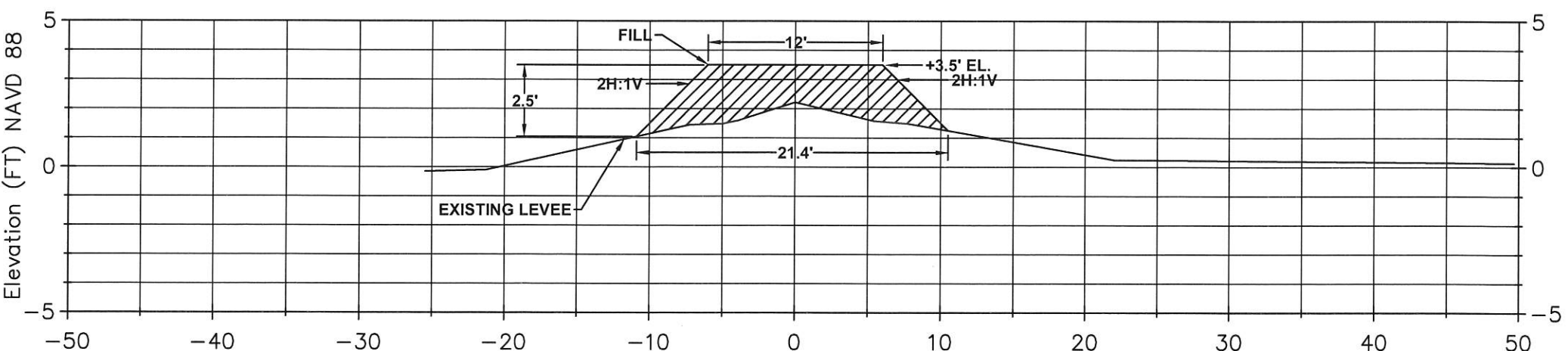

STATION 10+00.00  
HORIZONTAL SCALE: 1"=10', VERTICAL SCALE: 1"=5'

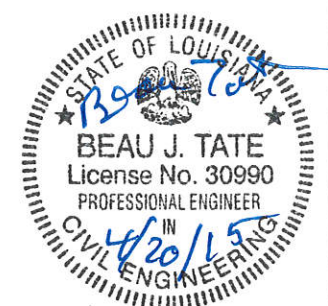

| REV. | DATE | DESCRIPTION | BY |
|------|------|-------------|----|
|      |      |             |    |
|      |      |             |    |
|      |      |             |    |
|      |      |             |    |

**ROYAL ENGINEERS & CONSULTANTS, LLC**  
 1231 CAMELLIA BOULEVARD  
 Lafayette, LOUISIANA 70508

**COASTAL PROTECTION AND RESTORATION AUTHORITY**  
 450 LAUREL STREET  
 BATON ROUGE, LOUISIANA 70801

HWY. 384 HYDROLOGIC RESTORATION PROJECT (CS-21) MAINTENANCE EVENT

CROSS SECTIONS  
LEVEE REPAIR

STATE PROJECT NUMBER: CS-21

FEDERAL PROJECT NUMBER: CS-21

APPROVED BY: BT

DATE: NOVEMBER 2014

DRAWN BY: TH

DESIGNED BY: BT

SHEET 12 OF 25

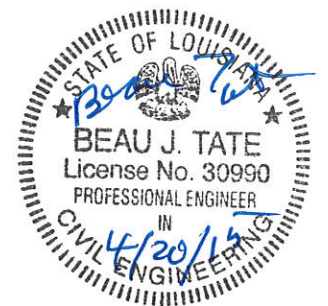
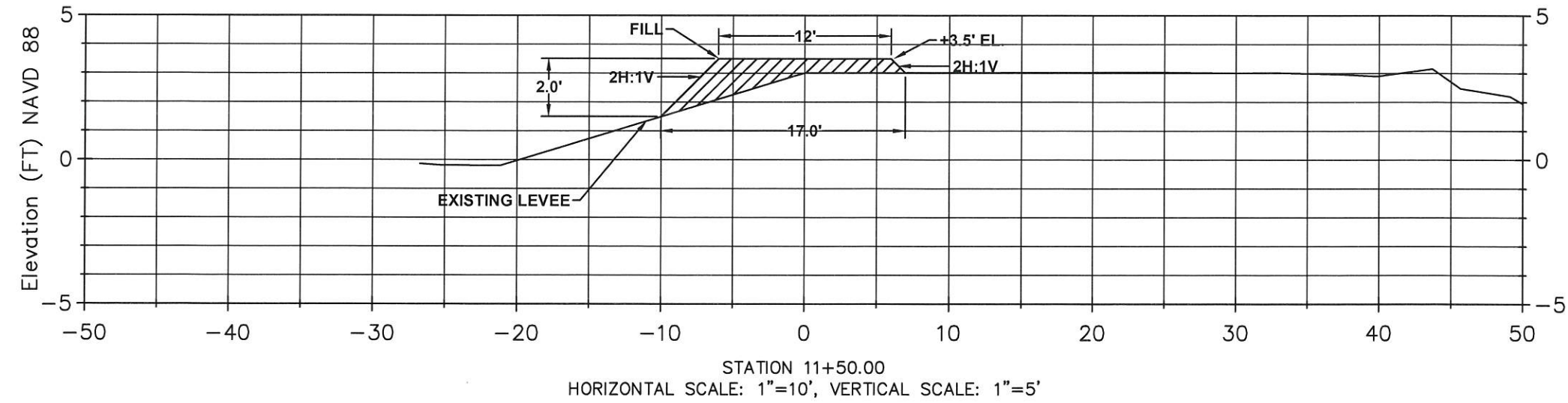
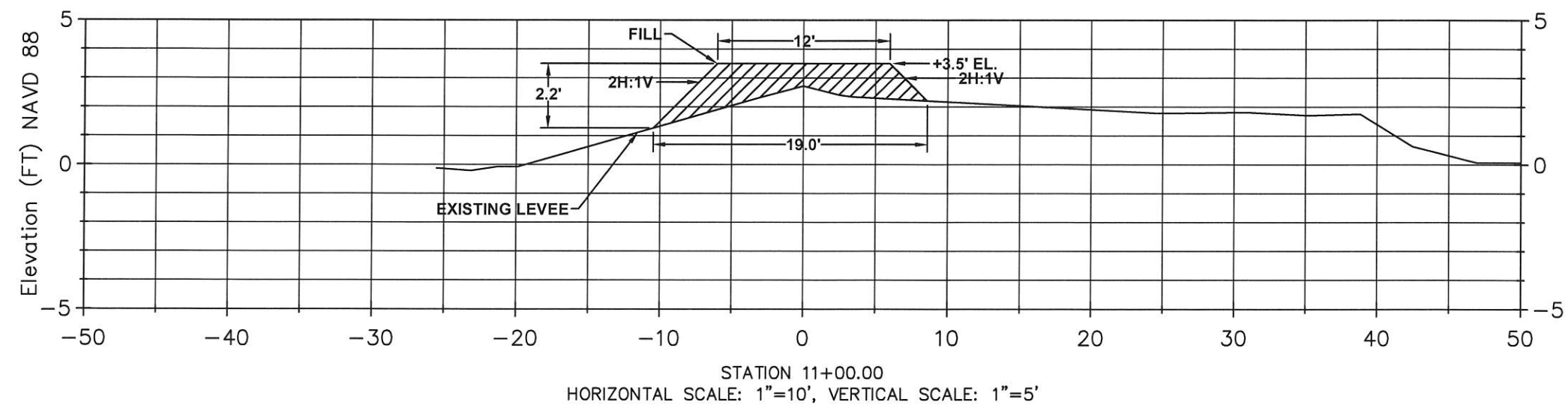
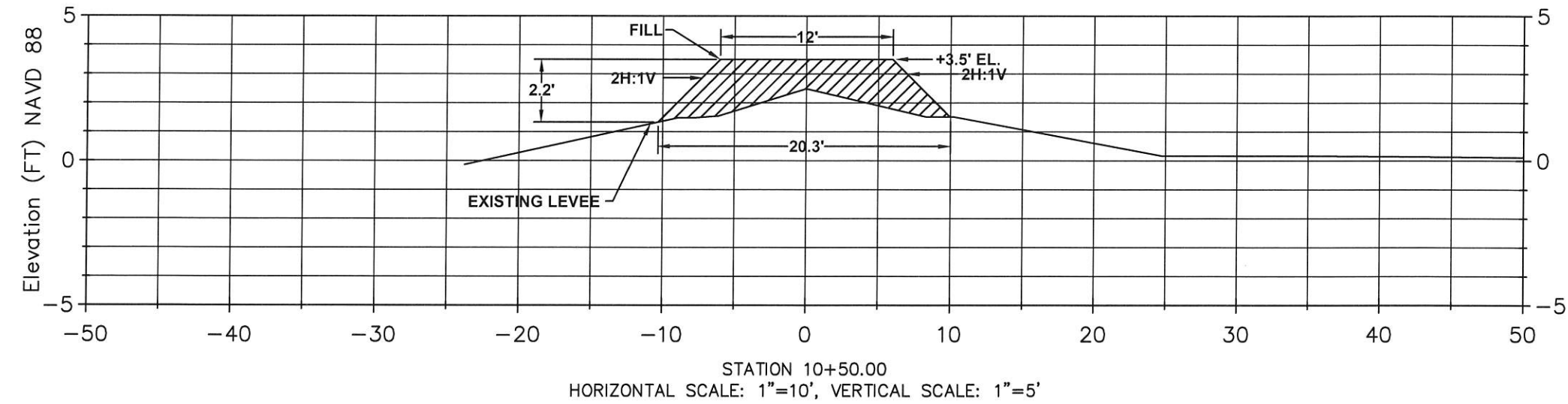

|  |      |             |    |  |                 |  |  |   |  |
|--|------|-------------|----|--|-----------------|--|--|---|--|
|  <b>ROYAL ENGINEERS &amp; CONSULTANTS, LLC</b><br>1231 CAMELLIA BOULEVARD<br>Lafayette, LOUISIANA 70508 |      |             |    | <b>COASTAL PROTECTION AND RESTORATION AUTHORITY</b><br>450 LAUREL STREET<br>BATON ROUGE, LOUISIANA 70801 |                 | HWY. 384 HYDROLOGIC RESTORATION PROJECT (CS-21) MAINTENANCE EVENT<br>STATE PROJECT NUMBER: CS-21<br>FEDERAL PROJECT NUMBER: CS-21<br>APPROVED BY: BT |  | <b>CROSS SECTIONS<br/>LEVEE REPAIR</b><br>DATE: NOVEMBER 2014<br>SHEET 13 OF 25 |  |
| REV.   | DATE | DESCRIPTION | BY | DRAWN BY: TH   | DESIGNED BY: BT |  |  |   |  |

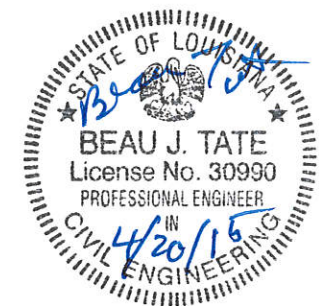
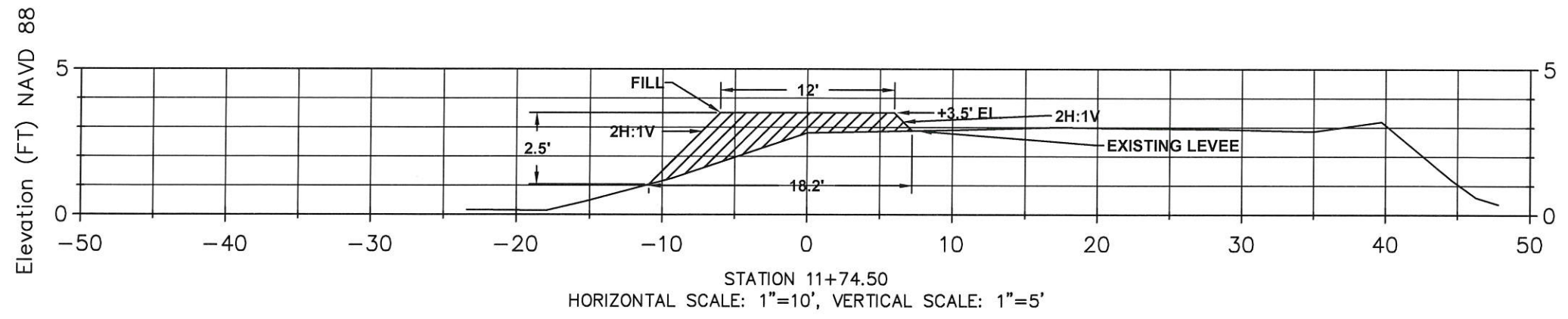

|      |      |             |    |  |  |  |   |                |                                |
|------|------|-------------|----|--|--|--|---|----------------|--------------------------------|
|      |      |             |    |  <b>ROYAL ENGINEERS &amp; CONSULTANTS, LLC</b><br>1231 CAMELLIA BOULEVARD<br>Lafayette, LOUISIANA 70508 | <b>COASTAL PROTECTION AND RESTORATION AUTHORITY</b><br>450 LAUREL STREET<br>BATON ROUGE, LOUISIANA 70801 |  | HWY. 384 HYDROLOGIC RESTORATION PROJECT (CS-21) MAINTENANCE EVENT |                | CROSS SECTIONS<br>LEVEE REPAIR |
|      |      |             |    |  |  |  | DRAWN BY: TH      DESIGNED BY: BT                                 |                |                                |
| REV. | DATE | DESCRIPTION | BY |  |  |  |   | SHEET 14 OF 25 |                                |

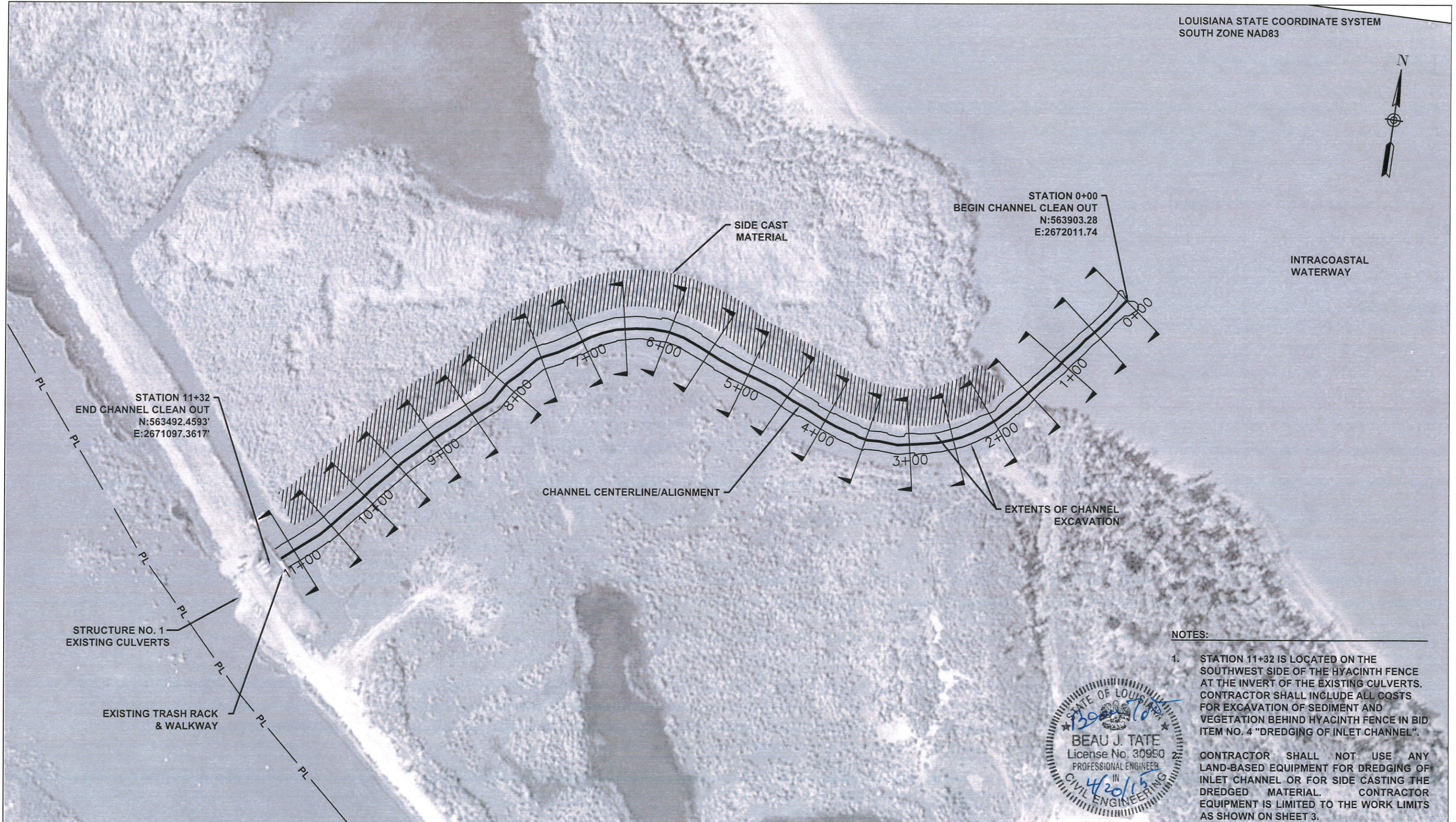

**NOTES:**

- STATION 11+32 IS LOCATED ON THE SOUTHWEST SIDE OF THE HYACINTH FENCE AT THE INVERT OF THE EXISTING CULVERTS. CONTRACTOR SHALL INCLUDE ALL COSTS FOR EXCAVATION OF SEDIMENT AND VEGETATION BEHIND HYACINTH FENCE IN BID ITEM NO. 4 "DREDGING OF INLET CHANNEL".
- CONTRACTOR SHALL NOT USE ANY LAND-BASED EQUIPMENT FOR DREDGING OF INLET CHANNEL OR FOR SIDE CASTING THE DREDGED MATERIAL. CONTRACTOR EQUIPMENT IS LIMITED TO THE WORK LIMITS AS SHOWN ON SHEET 3.

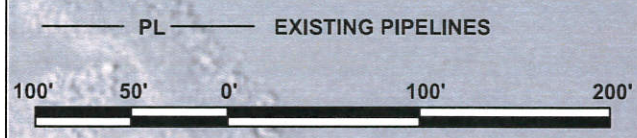
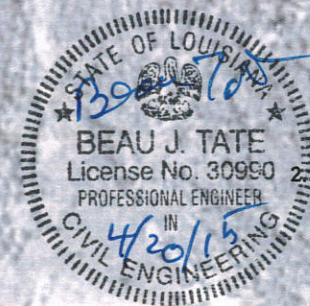

| REV. | DATE | DESCRIPTION | BY |
|------|------|-------------|----|
|      |      |             |    |
|      |      |             |    |
|      |      |             |    |



**ROYAL ENGINEERS  
& CONSULTANTS, LLC**  
1231 CAMELLIA BOULEVARD  
Lafayette, LOUISIANA 70508

**COASTAL PROTECTION AND  
RESTORATION AUTHORITY**  
450 LAUREL STREET  
BATON ROUGE, LOUISIANA 70801

HWY. 384 HYDROLOGIC RESTORATION  
PROJECT (CS-21) MAINTENANCE EVENT

SITE PLAN  
CHANNEL CLEANOUT

DRAWN BY: TH

DESIGNED BY: BT

APPROVED BY: BT

DATE: NOVEMBER 2014

SHEET 15 OF 25

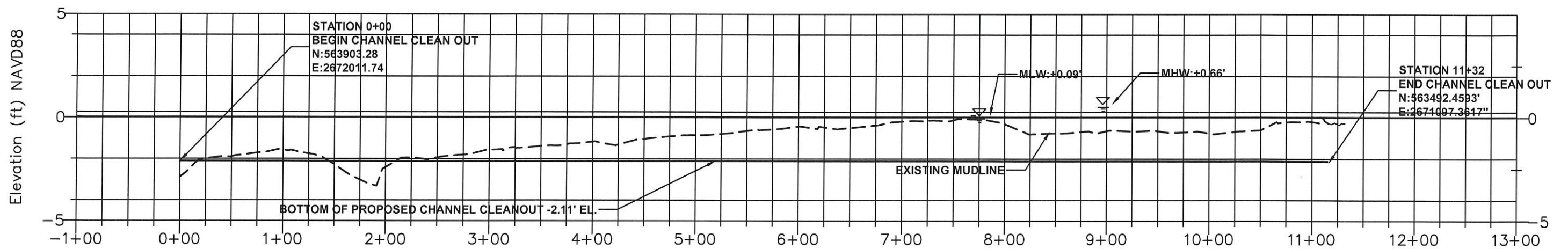

**CHANNEL PROFILE**  
 HORIZONTAL SCALE: 1"=100', VERTICAL SCALE: 1"=5'

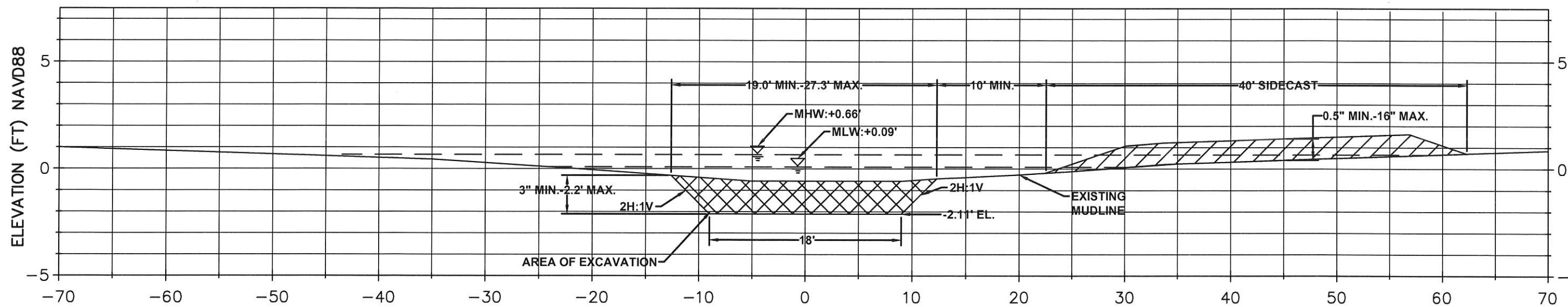

**TYPICAL CROSS-SECTION**  
 HORIZONTAL SCALE: 1"=10', VERTICAL SCALE: 1"=5'

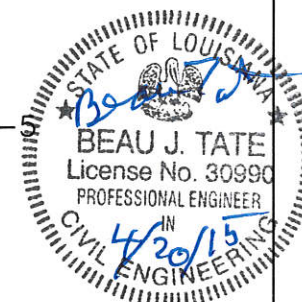

| REV. | DATE | DESCRIPTION | BY |
|------|------|-------------|----|
|      |      |             |    |
|      |      |             |    |
|      |      |             |    |



**ROYAL ENGINEERS  
 & CONSULTANTS, LLC**  
 1231 CAMELLIA BOULEVARD  
 Lafayette, LOUISIANA 70508

**COASTAL PROTECTION AND  
 RESTORATION AUTHORITY**

450 LAUREL STREET  
 BATON ROUGE, LOUISIANA 70801

DRAWN BY: TH

DESIGNED BY: BT

HWY. 384 HYDROLOGIC RESTORATION  
 PROJECT (CS-21) MAINTENANCE EVENT

STATE PROJECT NUMBER: CS-21

FEDERAL PROJECT NUMBER: CS-21

APPROVED BY: BT

PROFILE AND TYPICAL  
 CROSS SECTIONS

DATE: NOVEMBER 2014

SHEET 16 OF 25

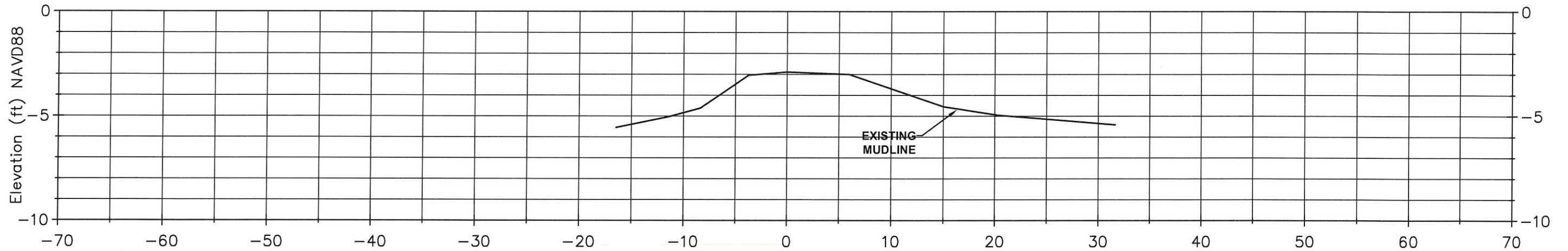

STATION 0+00.00  
HORIZONTAL SCALE: 1"=10', VERTICAL SCALE: 1"=5'

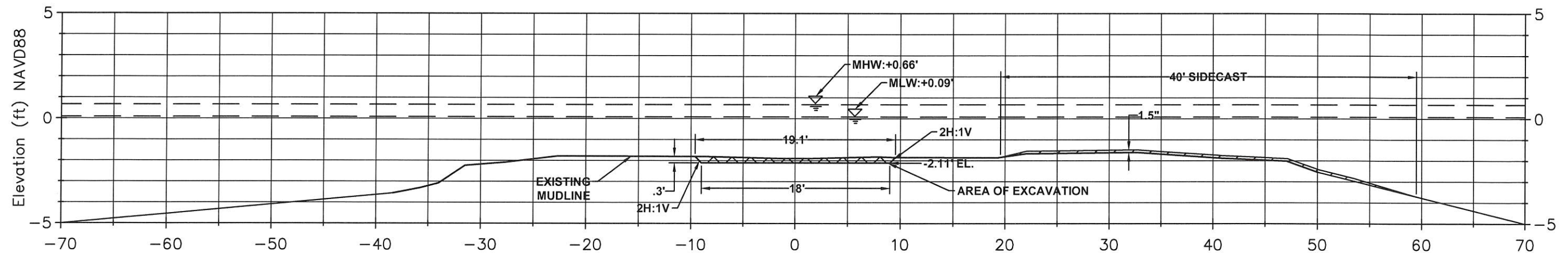

STATION 0+50.00  
HORIZONTAL SCALE: 1"=10', VERTICAL SCALE: 1"=5'

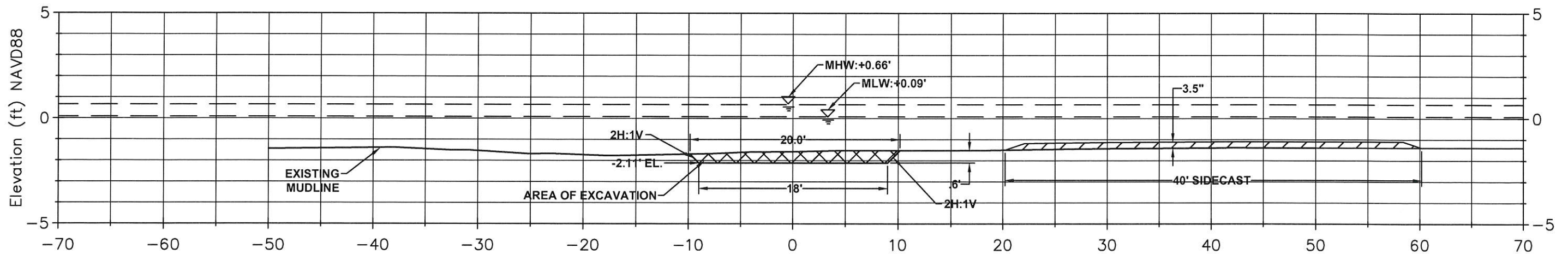

STATION 1+00.00  
HORIZONTAL SCALE: 1"=10', VERTICAL SCALE: 1"=5'

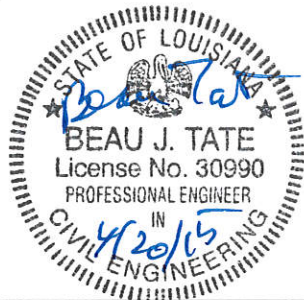

| REV. | DATE | DESCRIPTION | BY |
|------|------|-------------|----|
|      |      |             |    |
|      |      |             |    |
|      |      |             |    |

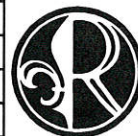

**ROYAL ENGINEERS  
& CONSULTANTS, LLC**  
1231 CAMELLIA BOULEVARD  
Lafayette, LOUISIANA 70508

**COASTAL PROTECTION AND  
RESTORATION AUTHORITY**

450 LAUREL STREET  
BATON ROUGE, LOUISIANA 70801

DRAWN BY: TH

DESIGNED BY: BT

HWY. 384 HYDROLOGIC RESTORATION  
PROJECT (CS-21) MAINTENANCE EVENT

STATE PROJECT NUMBER: CS-21

FEDERAL PROJECT NUMBER: CS-21

APPROVED BY: BT

CROSS SECTIONS  
CHANNEL CLEANOUT

DATE: NOVEMBER 2014

SHEET 17 OF 25



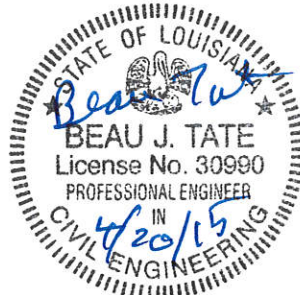
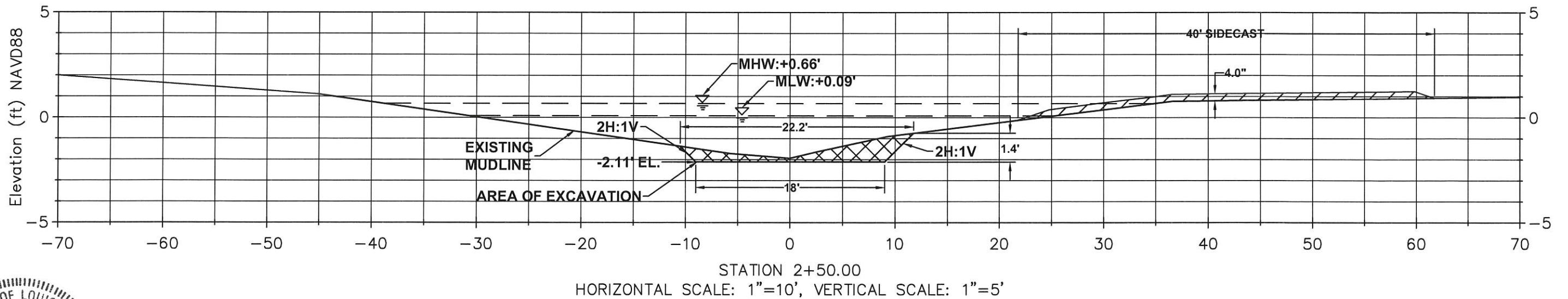
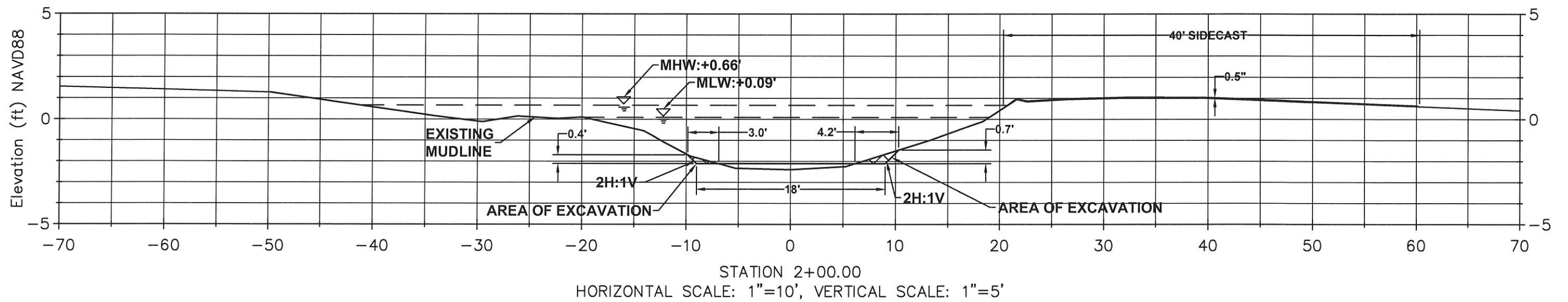
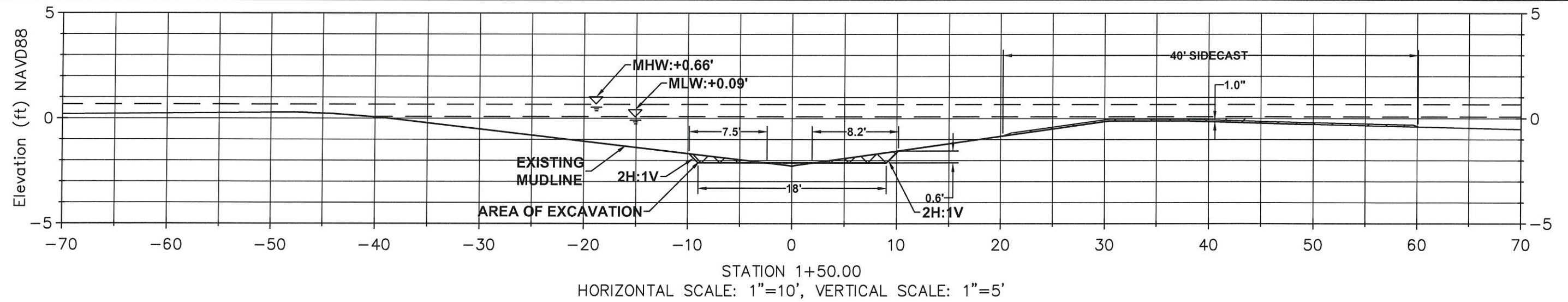

| REV. | DATE | DESCRIPTION | BY |
|------|------|-------------|----|
|      |      |             |    |
|      |      |             |    |
|      |      |             |    |

**ROYAL ENGINEERS & CONSULTANTS, LLC**  
 1231 CAMELLIA BOULEVARD  
 Lafayette, LOUISIANA 70508

**COASTAL PROTECTION AND RESTORATION AUTHORITY**  
 450 LAUREL STREET  
 BATON ROUGE, LOUISIANA 70801  
 DRAWN BY: TH      DESIGNED BY: BT

**HWY. 384 HYDROLOGIC RESTORATION PROJECT (CS-21) MAINTENANCE EVENT**  
 STATE PROJECT NUMBER: CS-21  
 FEDERAL PROJECT NUMBER: CS-21  
 APPROVED BY: BT

**CROSS SECTIONS CHANNEL CLEANOUT**  
 DATE: NOVEMBER 2014  
 SHEET 18 OF 25

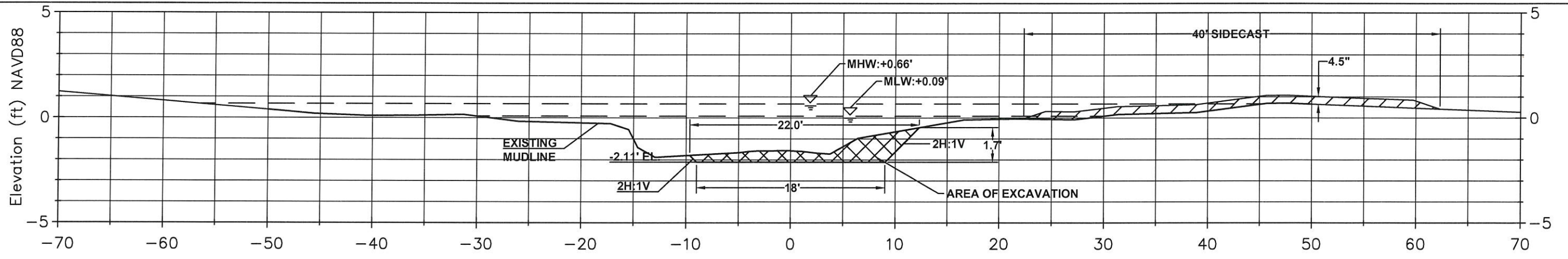

STATION 3+00.00  
HORIZONTAL SCALE: 1"=10', VERTICAL SCALE: 1"=5'

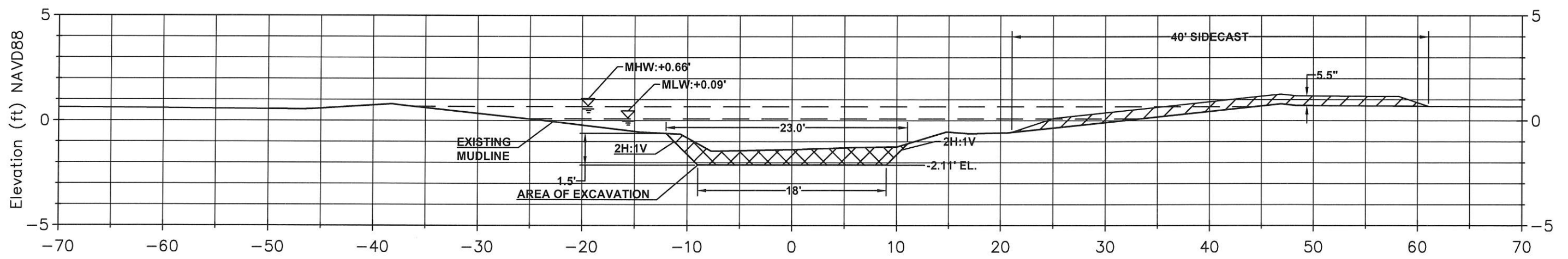

STATION 3+50.00  
HORIZONTAL SCALE: 1"=10', VERTICAL SCALE: 1"=5'

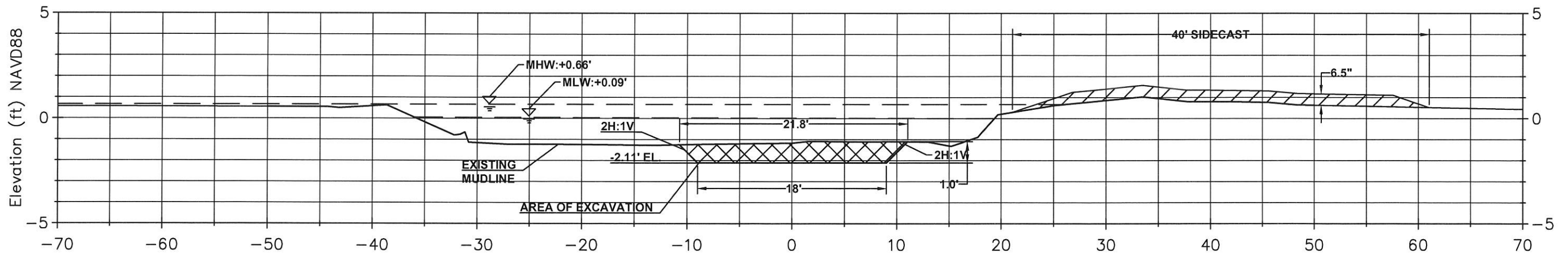

STATION 4+00.00  
HORIZONTAL SCALE: 1"=10', VERTICAL SCALE: 1"=5'

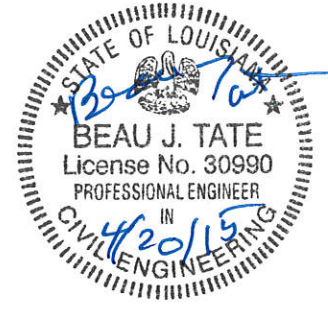

| REV. | DATE | DESCRIPTION | BY |
|------|------|-------------|----|
|      |      |             |    |
|      |      |             |    |
|      |      |             |    |

**ROYAL ENGINEERS & CONSULTANTS, LLC**  
 1231 CAMELLIA BOULEVARD  
 Lafayette, LOUISIANA 70508

**COASTAL PROTECTION AND RESTORATION AUTHORITY**  
 450 LAUREL STREET  
 BATON ROUGE, LOUISIANA 70801  
 DRAWN BY: TH      DESIGNED BY: BT

**HWY. 384 HYDROLOGIC RESTORATION PROJECT (CS-21) MAINTENANCE EVENT**  
 STATE PROJECT NUMBER: CS-21  
 FEDERAL PROJECT NUMBER: CS-21  
 APPROVED BY: BT

**CROSS SECTIONS CHANNEL CLEANOUT**  
 DATE: NOVEMBER 2014  
 SHEET 19 OF 25

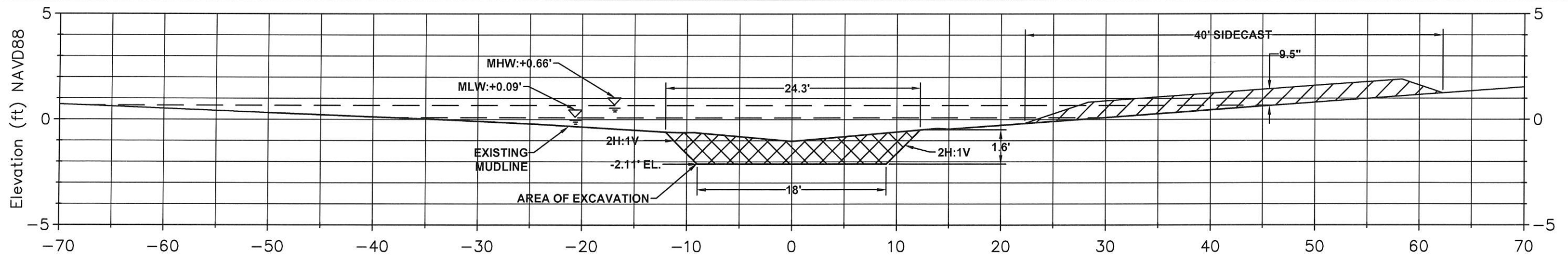

STATION 4+50.00  
HORIZONTAL SCALE: 1"=10', VERTICAL SCALE: 1"=5'

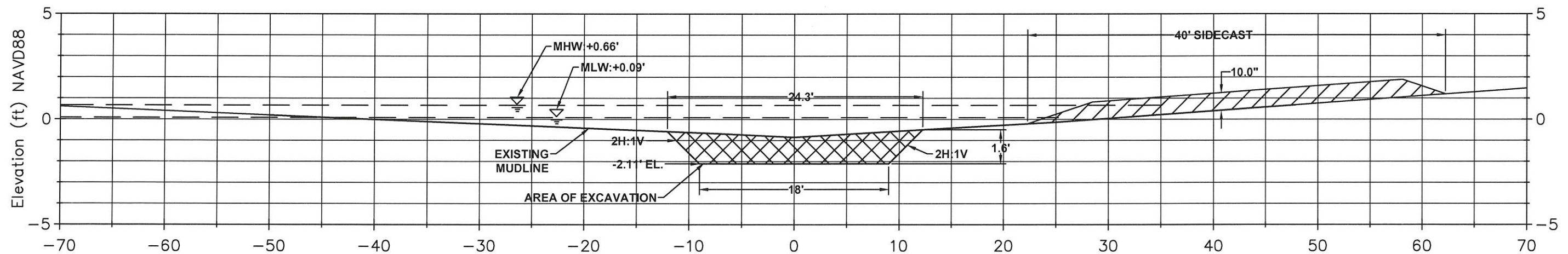

STATION 5+00.00  
HORIZONTAL SCALE: 1"=10', VERTICAL SCALE: 1"=5'

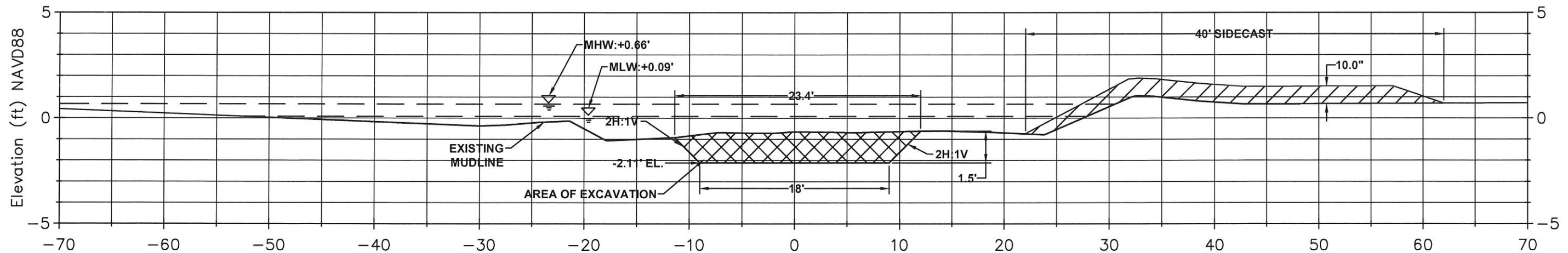

STATION 5+50.00  
HORIZONTAL SCALE: 1"=10', VERTICAL SCALE: 1"=5'

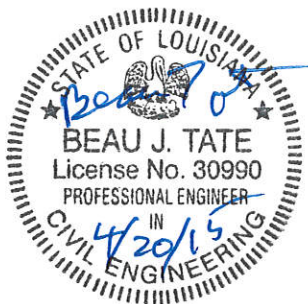

| REV. | DATE | DESCRIPTION | BY |
|------|------|-------------|----|
|      |      |             |    |
|      |      |             |    |
|      |      |             |    |



ROYAL ENGINEERS  
& CONSULTANTS, LLC  
1231 CAMELLIA BOULEVARD  
Lafayette, LOUISIANA 70508

COASTAL PROTECTION AND  
RESTORATION AUTHORITY

450 LAUREL STREET  
BATON ROUGE, LOUISIANA 70801

DRAWN BY: TH

DESIGNED BY: BT

HWY. 384 HYDROLOGIC RESTORATION  
PROJECT (CS-21) MAINTENANCE EVENT

STATE PROJECT NUMBER: CS-21

FEDERAL PROJECT NUMBER: CS-21

APPROVED BY: BT

CROSS SECTIONS  
CHANNEL CLEANOUT

DATE: NOVEMBER 2014

SHEET 20 OF 25

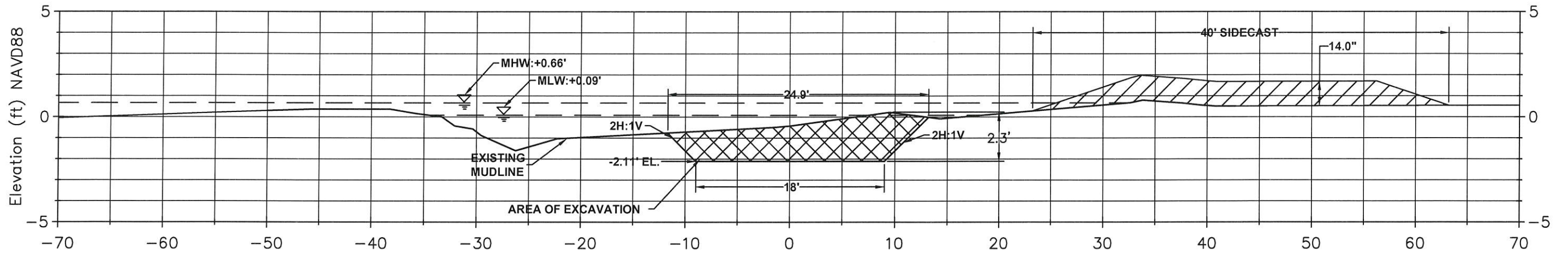

STATION 6+00.00  
HORIZONTAL SCALE: 1"=10', VERTICAL SCALE: 1"=5'

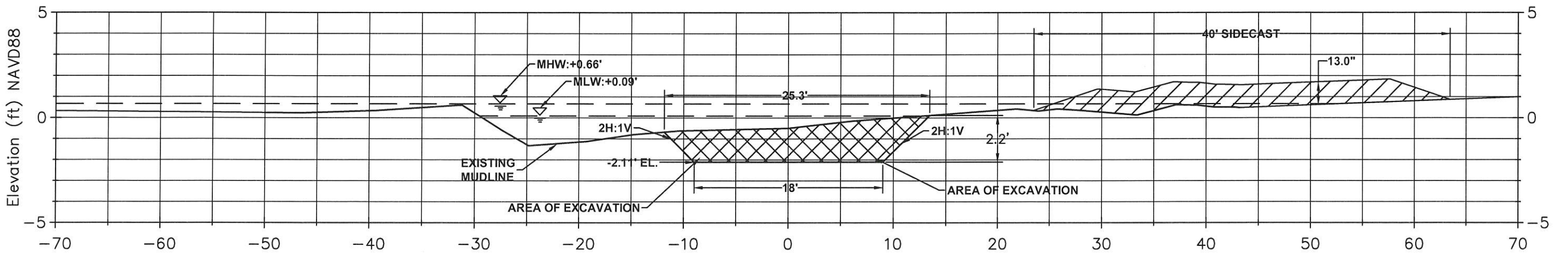

STATION 6+50.00  
HORIZONTAL SCALE: 1"=10', VERTICAL SCALE: 1"=5'

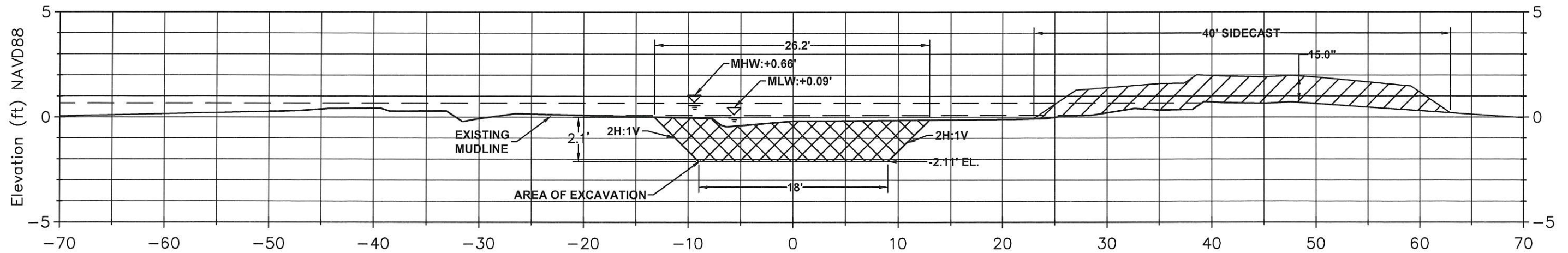

STATION 7+00.00  
HORIZONTAL SCALE: 1"=10', VERTICAL SCALE: 1"=5'

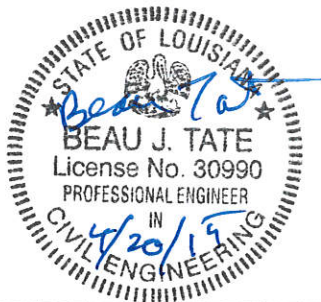

| REV. | DATE | DESCRIPTION | BY |
|------|------|-------------|----|
|      |      |             |    |
|      |      |             |    |
|      |      |             |    |

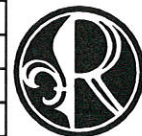

ROYAL ENGINEERS  
& CONSULTANTS, LLC  
1231 CAMELLIA BOULEVARD  
Lafayette, LOUISIANA 70508

COASTAL PROTECTION AND  
RESTORATION AUTHORITY

450 LAUREL STREET  
BATON ROUGE, LOUISIANA 70801

DRAWN BY: TH

DESIGNED BY: BT

HWY. 384 HYDROLOGIC RESTORATION  
PROJECT (CS-21) MAINTENANCE EVENT

STATE PROJECT NUMBER: CS-21

FEDERAL PROJECT NUMBER: CS-21

APPROVED BY: BT

CROSS SECTIONS  
CHANNEL CLEANOUT

DATE: NOVEMBER 2014

SHEET 21 OF 25

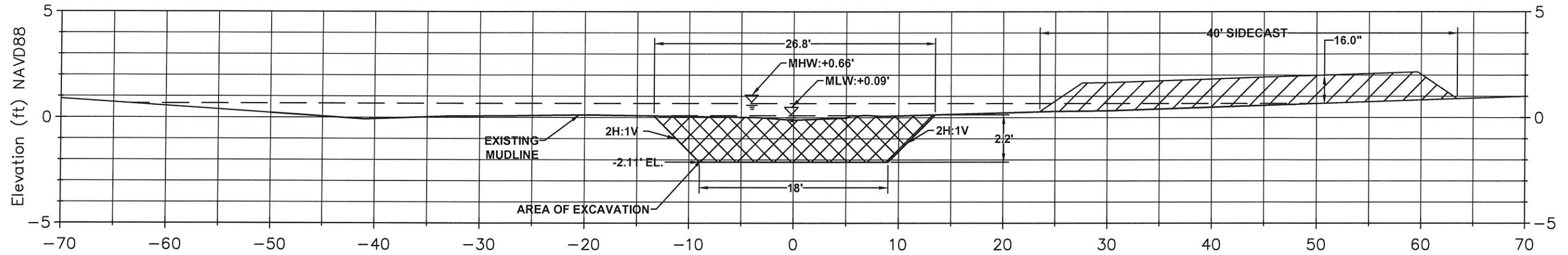

STATION 7+50.00  
HORIZONTAL SCALE: 1"=10', VERTICAL SCALE: 1"=5'

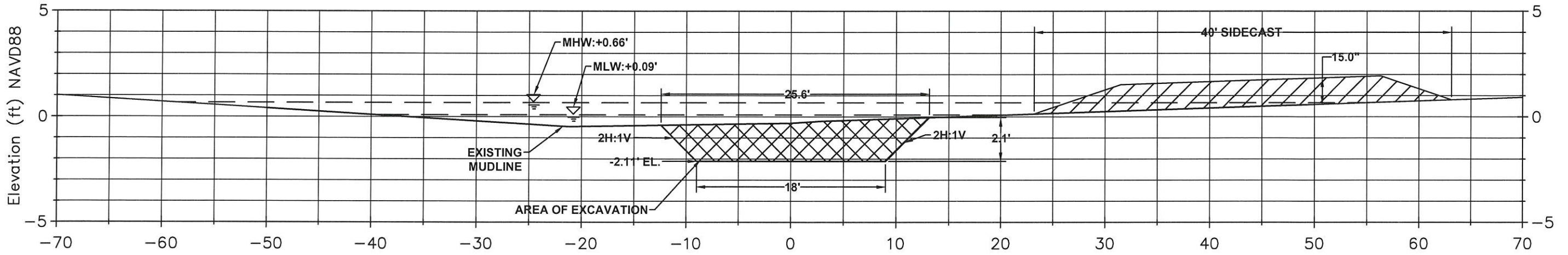

STATION 8+00.00  
HORIZONTAL SCALE: 1"=10', VERTICAL SCALE: 1"=5'

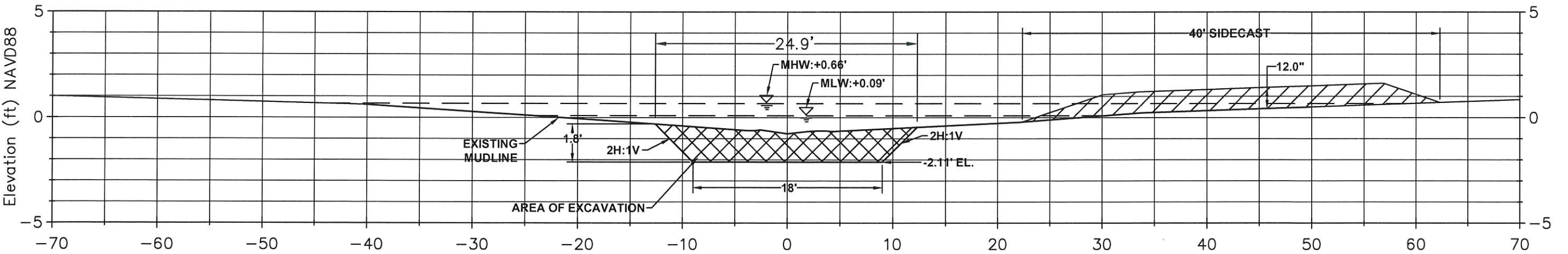

STATION 8+50.00  
HORIZONTAL SCALE: 1"=10', VERTICAL SCALE: 1"=5'

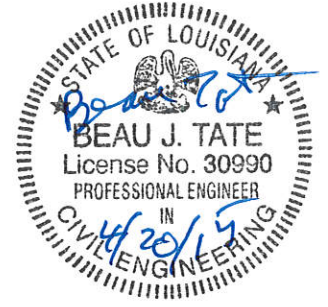

| REV. | DATE | DESCRIPTION | BY |
|------|------|-------------|----|
|      |      |             |    |
|      |      |             |    |
|      |      |             |    |



ROYAL ENGINEERS  
& CONSULTANTS, LLC  
1231 CAMELLIA BOULEVARD  
Lafayette, LOUISIANA 70508

COASTAL PROTECTION AND RESTORATION AUTHORITY

450 LAUREL STREET  
BATON ROUGE, LOUISIANA 70801

DRAWN BY: TH

DESIGNED BY: BT

HWY. 384 HYDROLOGIC RESTORATION PROJECT (CS-21) MAINTENANCE EVENT

STATE PROJECT NUMBER: CS-21

FEDERAL PROJECT NUMBER: CS-21

APPROVED BY: BT

CROSS SECTIONS CHANNEL CLEANOUT

DATE: NOVEMBER 2014

SHEET 22 OF 25

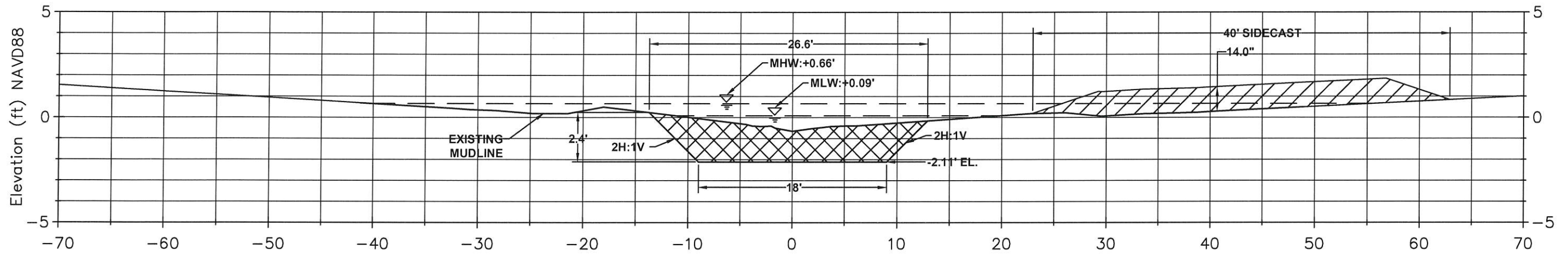

STATION 9+00.00  
HORIZONTAL SCALE: 1"=10', VERTICAL SCALE: 1"=5'

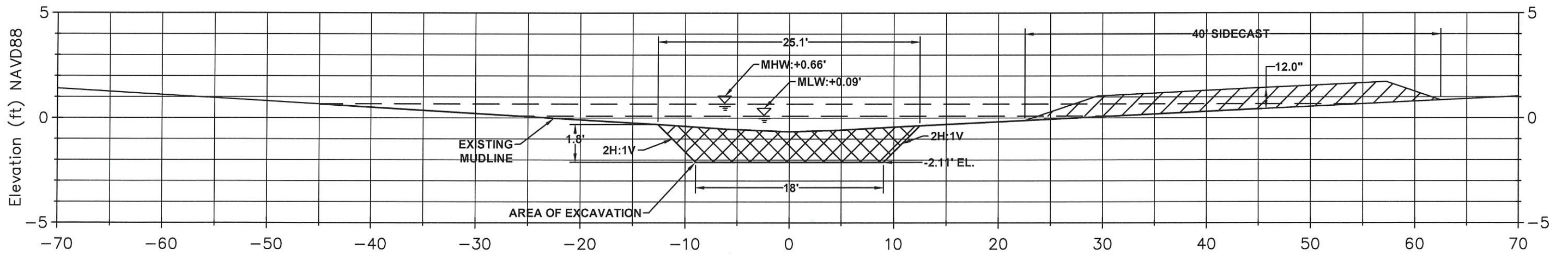

STATION 9+50.00  
HORIZONTAL SCALE: 1"=10', VERTICAL SCALE: 1"=5'

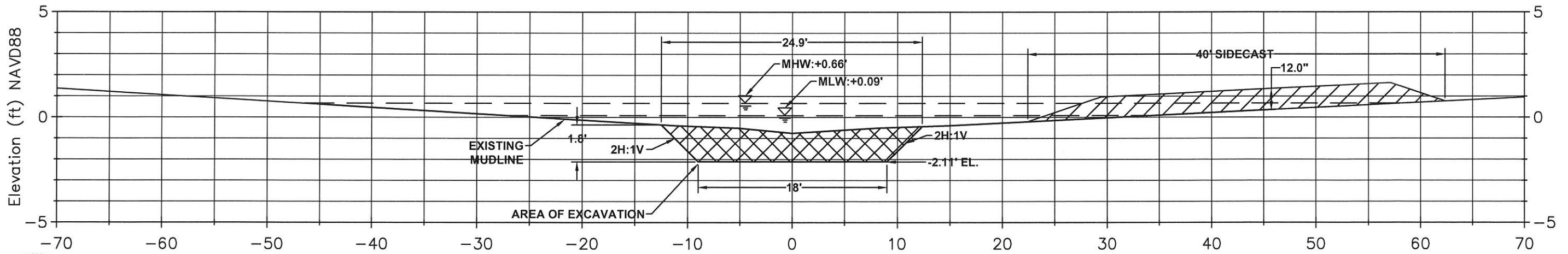

STATION 10+00.00  
HORIZONTAL SCALE: 1"=10', VERTICAL SCALE: 1"=5'

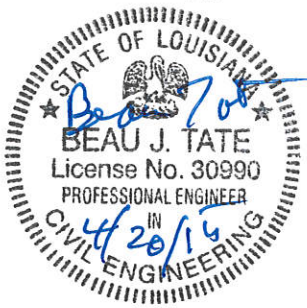

| REV. | DATE | DESCRIPTION | BY |
|------|------|-------------|----|
|      |      |             |    |
|      |      |             |    |
|      |      |             |    |

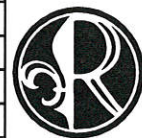

ROYAL ENGINEERS  
& CONSULTANTS, LLC  
1231 CAMELLIA BOULEVARD  
Lafayette, LOUISIANA 70508

COASTAL PROTECTION AND  
RESTORATION AUTHORITY

450 LAUREL STREET  
BATON ROUGE, LOUISIANA 70801

DRAWN BY: TH

DESIGNED BY: BT

HWY. 384 HYDROLOGIC RESTORATION  
PROJECT (CS-21) MAINTENANCE EVENT

STATE PROJECT NUMBER: CS-21

FEDERAL PROJECT NUMBER: CS-21

APPROVED BY: BT

CROSS SECTIONS  
CHANNEL CLEANOUT

DATE: NOVEMBER 2014

SHEET 23 OF 25

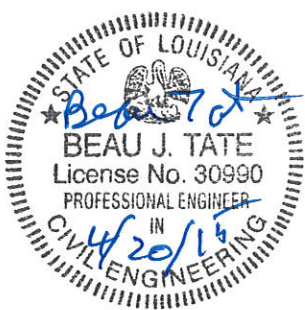
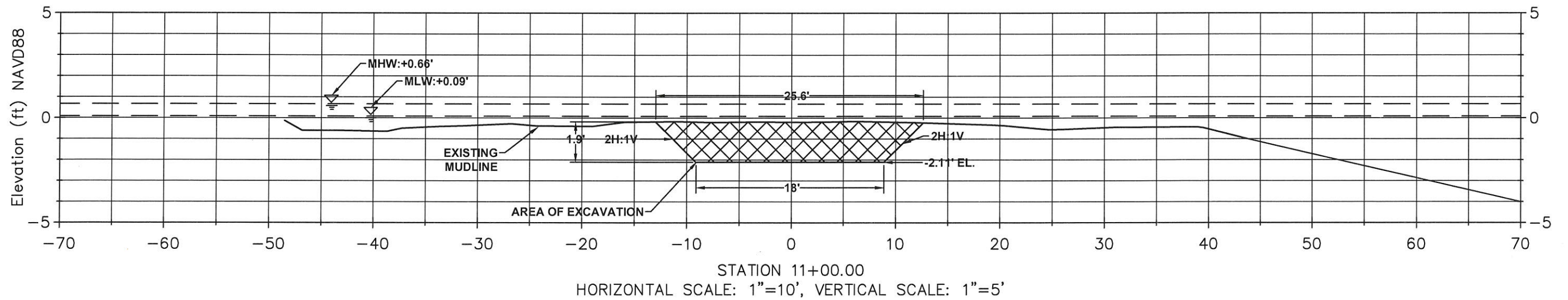
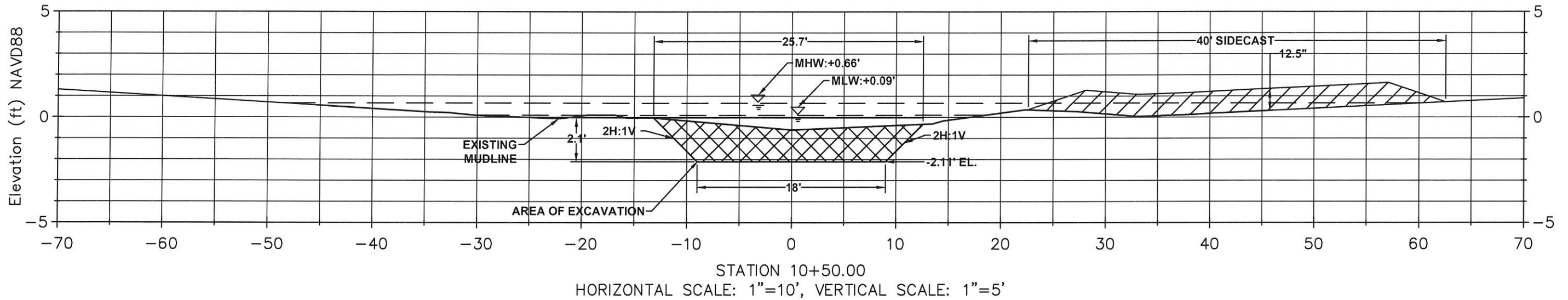

| REV. | DATE | DESCRIPTION | BY |
|------|------|-------------|----|
|      |      |             |    |
|      |      |             |    |
|      |      |             |    |
|      |      |             |    |



**ROYAL ENGINEERS  
& CONSULTANTS, LLC**  
1231 CAMELLIA BOULEVARD  
Lafayette, LOUISIANA 70508

**COASTAL PROTECTION AND  
RESTORATION AUTHORITY**

450 LAUREL STREET  
BATON ROUGE, LOUISIANA 70801

DRAWN BY: TH

DESIGNED BY: BT

HWY. 384 HYDROLOGIC RESTORATION  
PROJECT (CS-21) MAINTENANCE EVENT

STATE PROJECT NUMBER: CS-21

FEDERAL PROJECT NUMBER: CS-21

APPROVED BY: BT

CROSS SECTIONS  
CHANNEL CLEANOUT

DATE: NOVEMBER 2014

SHEET 24 OF 25

LOUISIANA STATE COORDINATE SYSTEM  
SOUTH ZONE NAD83



**STRUCTURE 1 DETAILS**

1. CULVERT MATERIAL: 24" X 43' CORRUGATED ALUMINUM PIPING
2. CULVERT SPACING: 5' CENTER-TO-CENTER SPACING

**NOTES:**

1. CONTRATOR SHALL REMOVE ANY DEBRIS AND/OR SEDIMENT AROUND THE HYACINTH FENCE THAT THE ENGINEER DEEMS AS PREVENTING STRUCTURE NO. 1 FROM FUNCTIONING PROPERLY.
2. CONTRACTOR SHALL REMOVE ALL DEBRIS FROM (3) CULVERTS TO ENSURE STRUCTURE NO. 1 FUNCTIONS PROPERLY. CONTRACTOR SHALL DETERMINE METHOD OF DEBRIS REMOVAL BASED ON SITE CONDITIONS. THE CONTRACTOR SHALL RECEIVE PRIOR APPROVAL FROM ENGINEER ON ANY METHOD OF REMOVAL TO BE USED. CONTRACTOR SHALL REPLACE ANY CULVERTS AND/OR GATES DAMAGED DURING THE DEBRIS REMOVAL PROCESSES AT NO EXPENSE TO THE OWNER. ENGINEER SHALL INSPECT CULVERTS WHEN ALL DEBRIS REMOVAL HAS BEEN COMPLETED TO ENSURE ADEQUATE REMOVAL OF DEBRIS FROM CULVERTS. WORK SHALL BE COMPLETE AFTER INSPECTION AND ACCEPTANCE BY ENGINEER.
3. CONTRACTOR SHALL REMOVE ANY DEBRIS, SEDIMENT, OR ROCKS FROM THE OUTLET SIDE FLAPGATE AREA PREVENTING THE STRUCTURE FROM FUNCTIONING PROPERLY, AS DETERMINED BY THE ENGINEER.
4. THE CONTRACTOR SHALL REPLACE ANY MISSING OR DAMAGED WIRE ON THE HYACINTH FENCE LOCATED AT STRUCTURE NO. 1. THE ENGINEER WILL DETERMINE ANY WIRE NEEDING REPLACEMENT ON HYACINTH FENCE.
5. THE CONTRACTOR SHALL REPLACE ANY LOOSE OR DETERIORATING BOARDS ON THE WALKWAY TO THE CONTINUOUS MONITORING STATION 29r LOCATED ADJACENT TO THE HYACINTH FENCE AT STRUCTURE NO.1. THE ENGINEER WILL DETERMINE ANY BOARDS NEEDING REPLACEMENT.
6. ANY DAMAGES TO STRUCTURE NO. 1 DURING CONSTRUCTION WILL BE REPAIRED BY THE CONTRACTOR AT NO COST TO THE OWNER.
7. ACTUAL SITE DETAILS AND LAYOUT MAY VARY FROM THAT SHOWN ON THE PLANS. A SITE VISIT BY THE CONTRACTOR IS REQUIRED PRIOR TO BIDDING TO VERIFY SITE CONDITIONS.

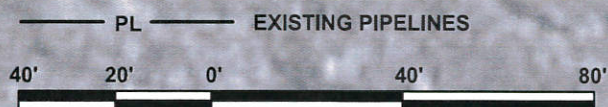
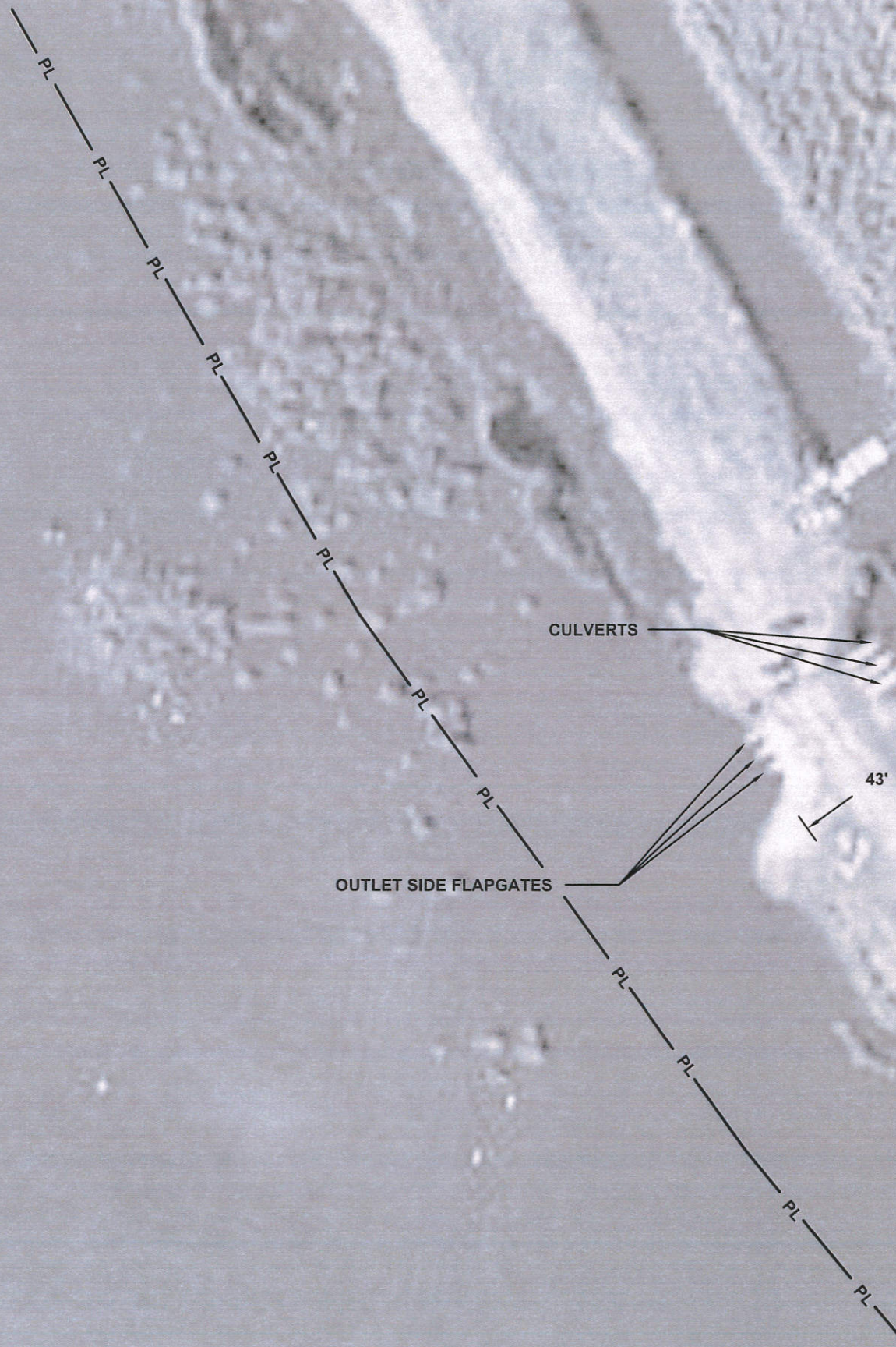

| REV. | DATE | DESCRIPTION | BY |
|------|------|-------------|----|
|      |      |             |    |
|      |      |             |    |
|      |      |             |    |
|      |      |             |    |



**ROYAL ENGINEERS  
& CONSULTANTS, LLC**  
1231 CAMELLIA BOULEVARD  
Lafayette, LOUISIANA 70508

**COASTAL PROTECTION AND  
RESTORATION AUTHORITY**

450 LAUREL STREET  
BATON ROUGE, LOUISIANA 70801

DRAWN BY: TH

DESIGNED BY: BT

HWY. 384 HYDROLOGIC RESTORATION  
PROJECT (CS-0021) MAINTENANCE EVENT

STATE PROJECT NUMBER: CS-0021

FEDERAL PROJECT NUMBER: CS-0021

APPROVED BY: BT

SITE PLAN STRUCTURE NO. 1  
STRUCTURE MAINTENANCE

DATE: NOVEMBER 2014

SHEET 25 OF 25